

Instruction, Use and Maintenance Manual

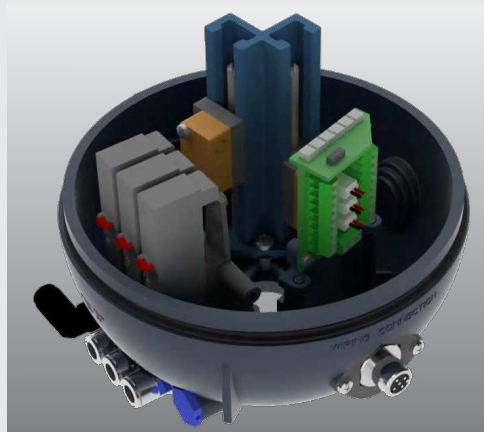

CONTROL UNITS **GIOTTO TOP®**

Bardiani Valvole S.p.A.

via G. di Vittorio, 50/52 - 43045 Fornovo di Taro (PR) - Italy

tel. +39 0525 400044 - fax +39 0525 3408

bardiani@bardiani.com - www.bardiani.com

MANUAL REVISION	DATE

INDEX

1	Safety, Warning and Mandatory Signs	5
1.1	Operator training	6
2	Safety	7
2.1	General safety warnings	7
3	Technical data	9
3.1	Giotto Top electrical connections	10
4	Checking / Unpacking / Lifting	14
5	Installation of the Giotto Top	15
6	Giotto Top Pneumatic connections	19
7	Troubleshooting	22
8	Cleaning	24
9	Disposal	25
10	Maintenance	26
10.1	Giotto Top Control unit	27
10.2	Disassembly / Assembly of the Giotto Top	29
11	Valve complete with control unit	34
12	Warranty	35
13	Recommendations	36

INTRODUCTION

This "Instruction, Use and Maintenance Manual" has been drawn up expressly for expert technical personnel. Consequently any information which can easily be deduced from reading the text and/or examining the illustrations and/or drawings provided herein shall not be the object of further explanation.

This "Instruction, Use and Maintenance Manual" forms an integral part of the control unit. Before proceeding with installation, use or maintenance of each type of control unit it is compulsory to read and understand this manual.

This manual must be kept for all future reference

When using valves in compliance with Directive 2014/34/EU (ATEX) it is mandatory to consult a specific manual.







It being understood that the essential characteristics of the type of control unit described herein shall remain the same, the manufacturer reserves the right to amend and/or integrate and/or update the data and/or information relative to use of the control unit provided in the "Instruction, Use and Maintenance Manual", at any time and without prior notice.

The latest, updated version of the "Instruction, Use and Maintenance Manual" is always available at www.bardiani.com

The manufacturer shall not in any way be held liable for any consequences resulting from a failure to correctly observe the prescriptions provided in the relative manual concerning installation, use, maintenance and care of the Product.

All rights reserved. It is prohibited, without prior written authorization from the manufacturer, to totally and/or partially reproduce and/or transmission and/or record any part of this "Instruction, Use and Maintenance Manual" using any means and/or support, including IT and/or electronic and/or mechanical and/or paper formats, or by means of any other system to save and/or reuse it for purposes different to the exclusive use by the purchaser.

1 Safety, Warning and Mandatory Signs

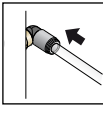
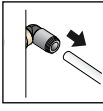
SIGNALS		
Pictogram	Description	Notes
	WARNING General	This tells the person in question that the operation described involves (when not performed in accordance with the relative safety regulations) the risk of personal injury.
	OBLIGATION General	Special instructions must be followed to avoid injury to persons.
	SKILLED PERSONNEL	Dismantling/Assembling and maintenance operations must be carried out by expert technicians only.
	NOTE	Follow the indicated note with care
	ELECTRICAL CONNECTION	Electrical connection to the control unit
	ELECTRICAL DISCONNECTION	Electrical disconnection from the control unit
	PNEUMATIC CONNECTION	Compressed air connection to the control unit
	PNEUMATIC DISCONNECTION	Compressed air disconnection from the control unit.

OPERATING SIGNS		
Pictogram	Description	Notes
	APPLICATION OF FOODSAFE GREASE	Use only FOODLUBE HI-TEMP 2 grease or equivalent

1.1 Operator training



All persons who have to work on the valve must be qualified to carry out the relative maintenance tasks.

They must be informed as to the possible hazards involved and must observe all the safety instructions set out in this manual.

Allow expert personnel only to work on the electrical components.

2 Safety

2.1 General safety warnings



Intended Use

The control unit has been designed to control the pneumatically controlled process valves manufactured by Bardiani Valvole S.p.A..

It is possible to fit the Giotto Top with a maximum of three solenoid valves for controlling the process valve and up to a maximum of four inductive sensors, including an external one for controlling the position.

For the electrical connections inside the control unit, there are three different configurations:

- LED terminal block and As-i card: the LEDs indicate, in the presence of the relative inductive sensor, the status of the valve: green light = valve open; yellow light = valve closed; white light = bottom or top lift activated.
- 10-pole terminal block: no LEDs.

General warnings

- Always read the technical data carefully before machine installation, operation and maintenance.
- The Giotto Top must always be installed, operated and maintained by authorized personnel. Said personnel must know and understand both the unit and the contents of the manual.
- Take care over any separate parts of the Giotto Top when removing it from its packaging.
- Always connect the air supply carefully and disconnect it after use.
- Always connect the power supply carefully and disconnect it after use.
- Never touch the moving parts in the Giotto Top or valves.
- Always handle detergents with care.

Prohibited use

Use of the control unit is not envisaged:

- for any operations other than those for which it was designed.



WARNING

The machine may not be used inside premises where there is a potentially explosive atmosphere or risk of fire unless otherwise stated by the manufacturer (in the case of valves certified in accordance with Directive 2014/34/EU please refer to the ATEX Manual).

**WARNING**

The control unit contains circuits classified as LOW VOLTAGE LIMITED ENERGY CIRCUIT. For correct use in North America dimension the protection circuits in accordance with Standard UL508A.

**WARNING**

ALWAYS make sure the electrical and pneumatic connections are NOT active when executing operations on the Giotto Top and that the power supply voltage is only 24 Vdc.

**WARNING**

Under normal circumstances (exposure time, eye pupils, viewing distance) it is assumed that the LEDs do not present any danger to eyes. In principle, however, please remember that intense light sources have a high potential of secondary exposure due to their blinding effect. As also occurs when looking at other bright light sources (such as vehicle high beams), there may be a temporary reduction in visual acuity and afterimage which can cause irritation, discomfort, eyesight issues and even injury, depending on the situation.



BARDIANI VALVOLE S.p.A. declines all liability for installation, use or maintenance which fails to comply with the indications provided in this manual!

3 Technical data

CONTROL UNIT TECHNICAL DATA	
Weight	from 0.55 Kg to 0.65 Kg depending on the configuration
Casing material	PA66 + PA6-GF30 (glass fibre reinforced nylon)
Gaskets material	NBR / EPDM
Protection class	IP67
Air supply and vent connections	1/8" BSP
Air line connections	6 mm / (1/4" ON REQUEST)
Electrical connections	7-pole connector, M12 5 pole connector, M12 8 pole connector, M12 12 pole connector
	Threaded fitting for cable gland PG11 or M20x1.5
AS-i connections	2m cable with M12 connector and branch for flat cable or M12 connector and branch for flat cable
Vibrations	1mm amplitude f=10..55Hz
Storage temperature	from -10°C to +25°C
Air supply	Class 2,4,3 according to ISO 8573-1

SOLENOID VALVE APPLICATION CRITERIA	
Single Acting Valves	1 Solenoid valve
Double Acting Valves (1 normally open and 1 normally closed with a single electric control), Mixproof and Twin-Stop valves (2 normally closed)	2 Solenoid valves
Mixproof valves with air supply for opening, top and bottom lift (3 normally closed)	3 Solenoid valves

SOLENOID VALVE TECHNICAL DATA	
Solenoid valve configuration	3/2
Electrical power supply	24 Vdc \pm 10%
Air pressure supply	max. 7bar min. 6bar
Ambient temperature for solenoid valve type B	0..+55°C
Ambient temperature for solenoid valve type S	-10..+50°C

INDUCTIVE SENSOR TECHNICAL DATA	
Electrical power supply	24 Vdc
Ambient temperature	-10..+70°C

AS-I CARD TECHNICAL DATA	
No. / type of inputs	4 / PNP
No. / type of outputs	3 / PNP
Ambient temperature	-10..+70°C
MAX absorbed current	220 mA
MAX total current (IN + OUT)	150 mA
AS-interface profile	S-7.A.7.F
As-interface specification	V 3.0
AS-interface IC	ASI4U
Extended addressing mode	✓
Solenoid valves type "B"	✓
Solenoid valves type "S"	✓

In the event of any doubt, please contact Bardiani Valvole S.p.A.

3.1 Giotto Top electrical connections

1,2 PNP sensors with 1,2,3 normally closed solenoid valves and 7-pin connector

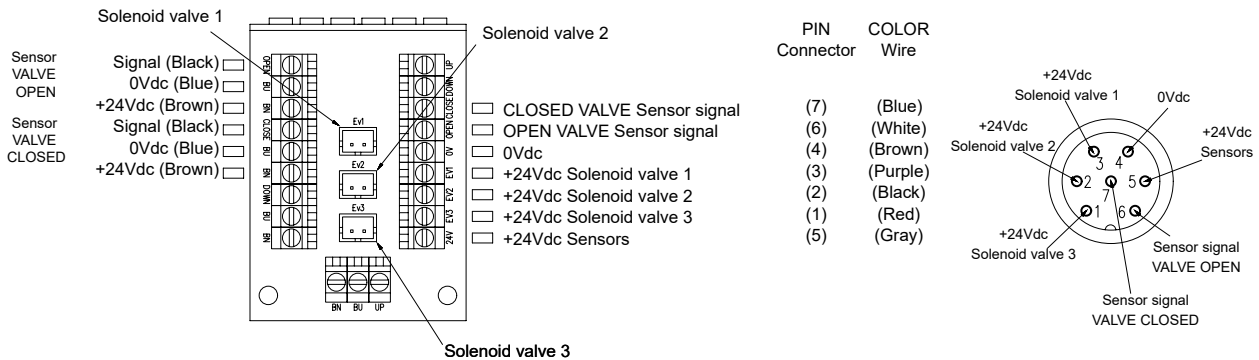

1,2 PNP sensors with 2 solenoid valves (1 N.C. and 1 N.O.) for double acting 7-pin connector

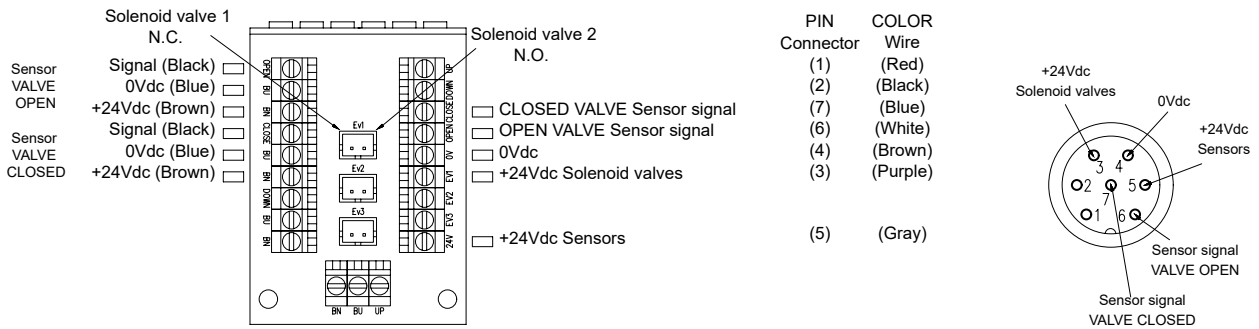

1,2 PNP sensors with 1 normally closed solenoid valves and 5-pin connector

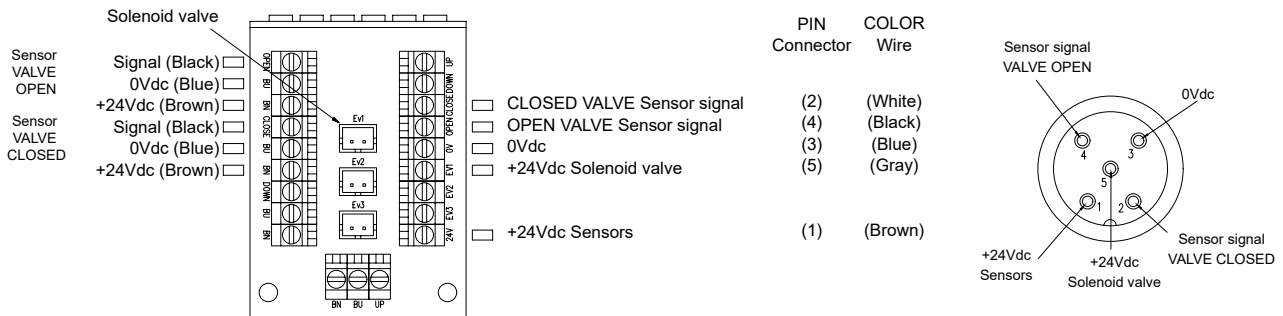

1,2 PNP sensors with 2 solenoid valves (1 N.C. and 1 N.O.) for double acting 5-pin connector

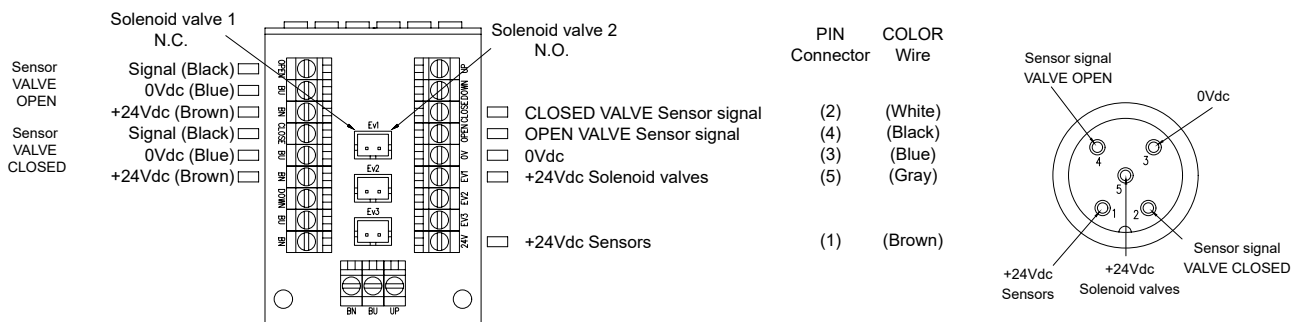

1,2,3 PNP sensors with 1,2,3 normally closed solenoid valves and 8-pin connector

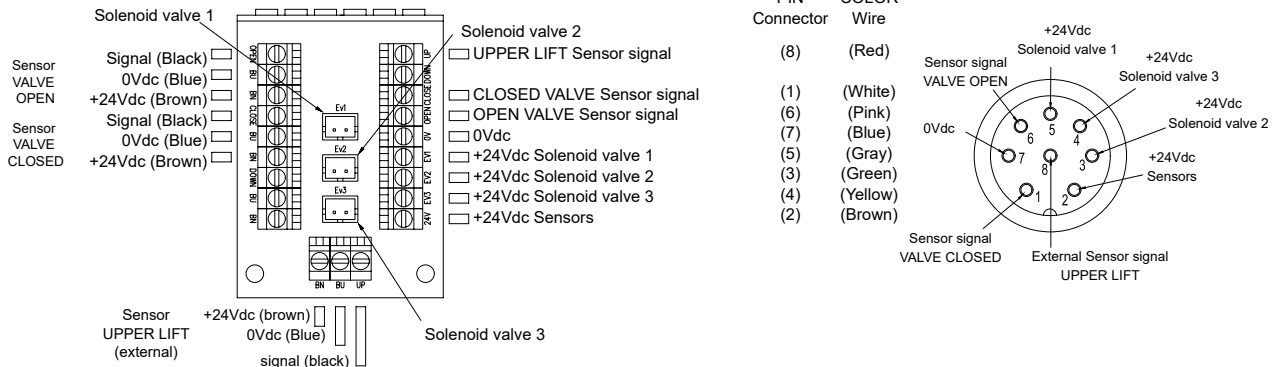

1,2,3 PNP sensors with 1,2,3 normally closed solenoid valves and 8-pin connector

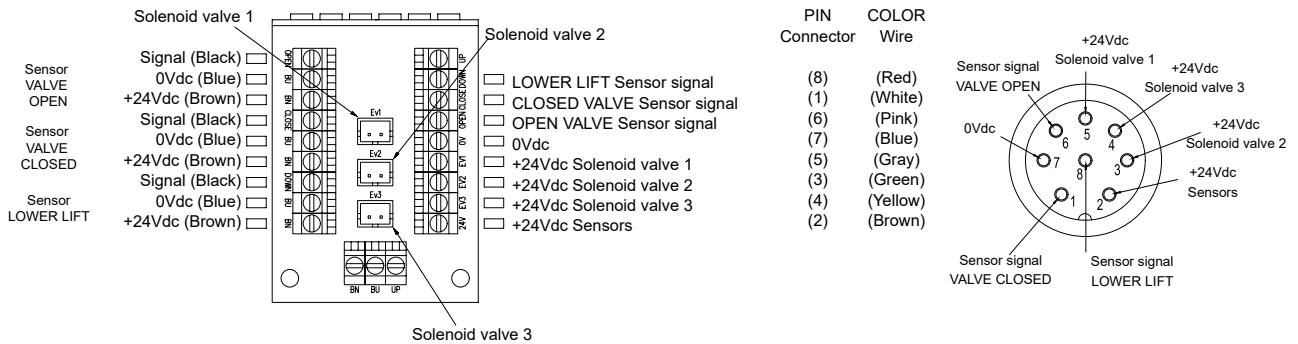

1,2,3,4 PNP sensors with 1,2,3 normally closed solenoid valves

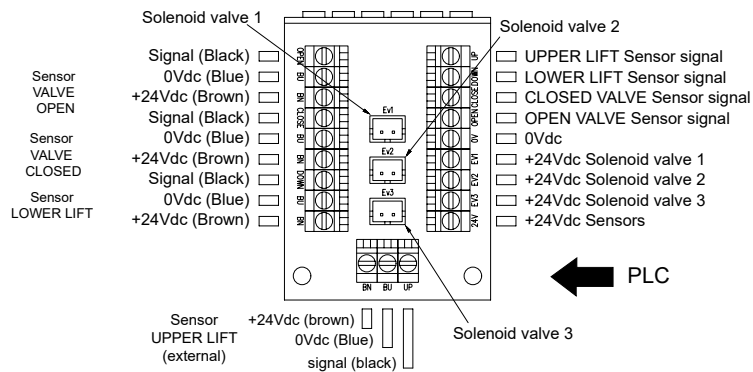

1,2 PNP sensors with 2 solenoid valves (1 N.C. and 1 N.O.) for double acting

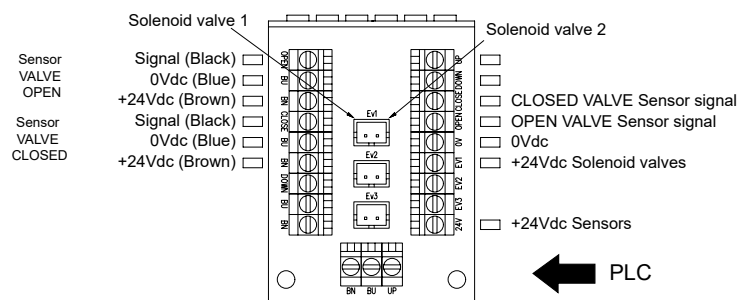

AS-i 360° Board 1,2,3,4 PNP sensors with 1,2,3 normally closed solenoid valves

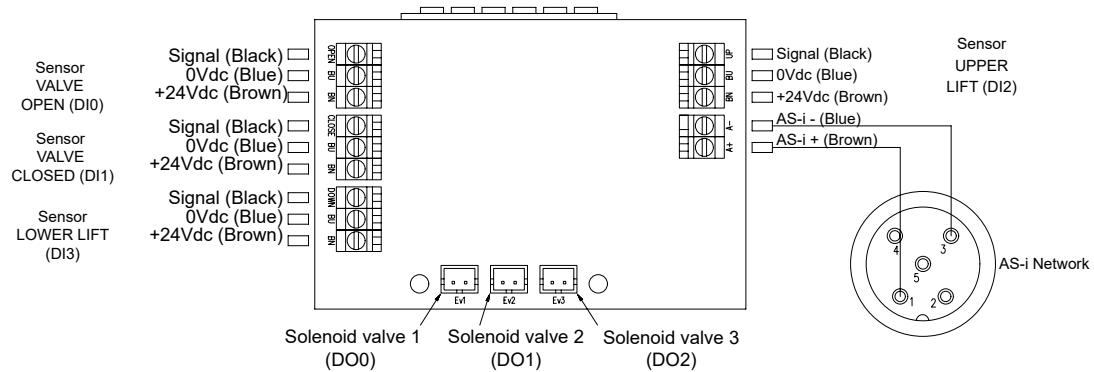

AS-i 360° Board 1,2 PNP sensors with 2 solenoid valves (1 N.C. and 1 N.O.) for double acting

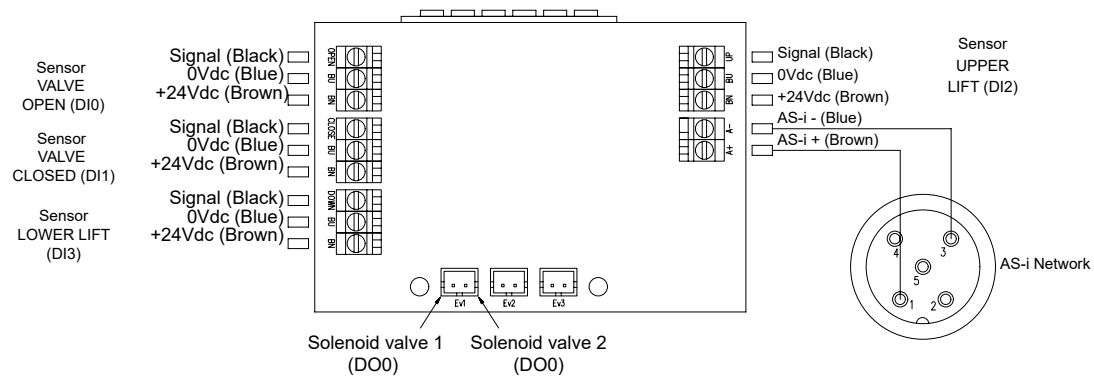

1,2,3 normally closed solenoid valves and 7-pin connector

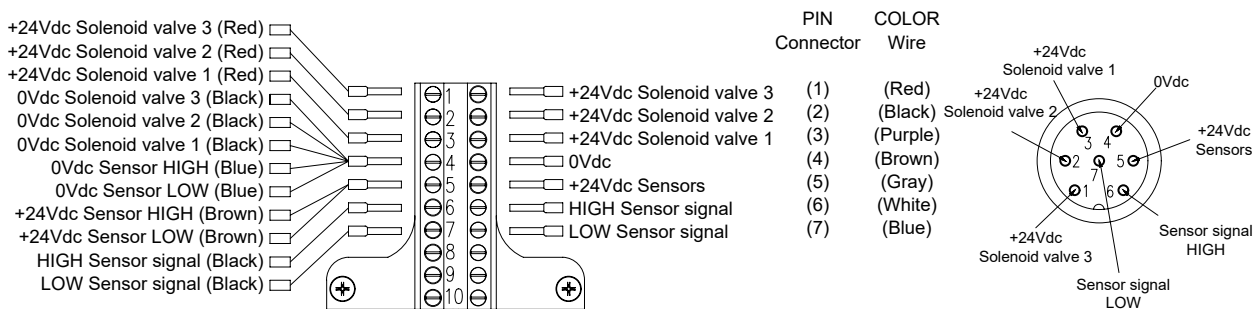

1,2,3 normally closed solenoid valves and 5-pin connector

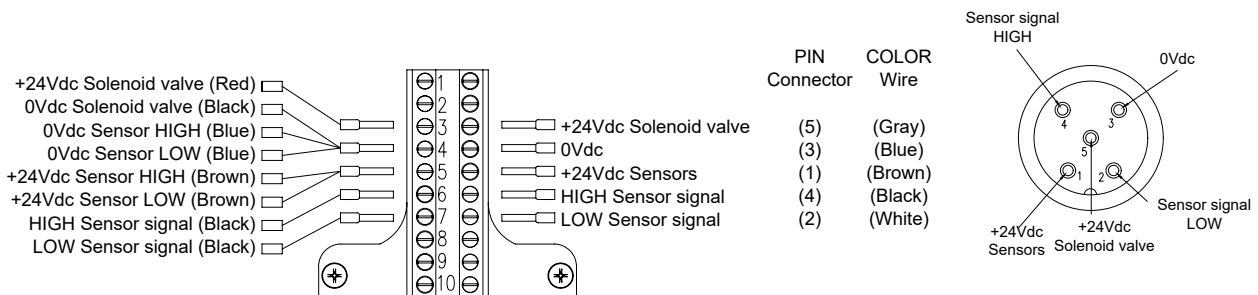

1,2,3,4 PNP sensors with 1,2,3 normally closed solenoid valves and 12-pin connector

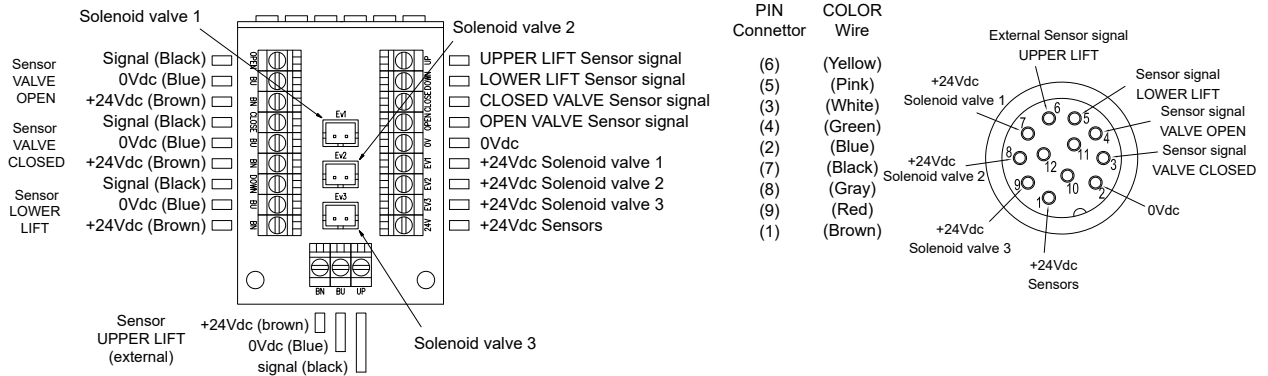

Mixproof (2 cams) , 3 PNP sensors and 3 solenoid valves normally closed with M12 8-pin connector

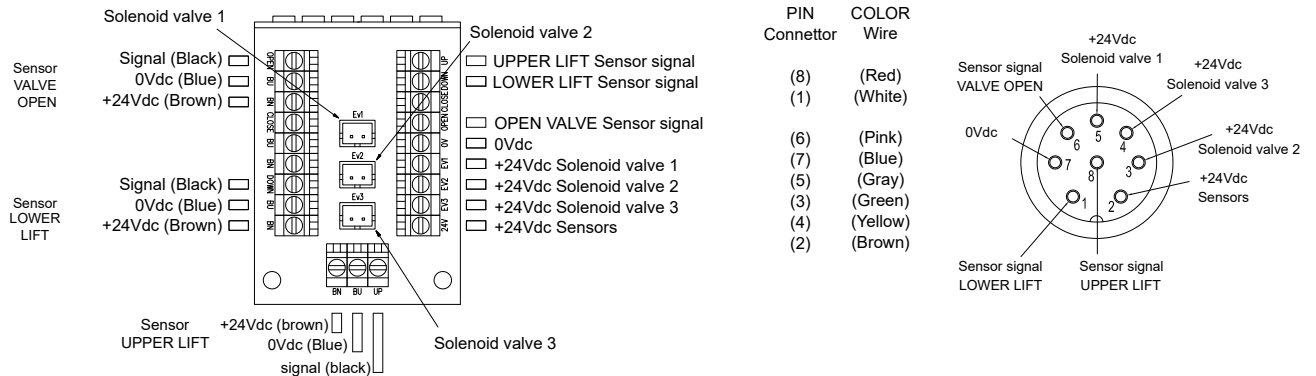

Mixproof (2 cams) with AS-i card 360°, 3 PNP sensors and 3 solenoid valves normally closed

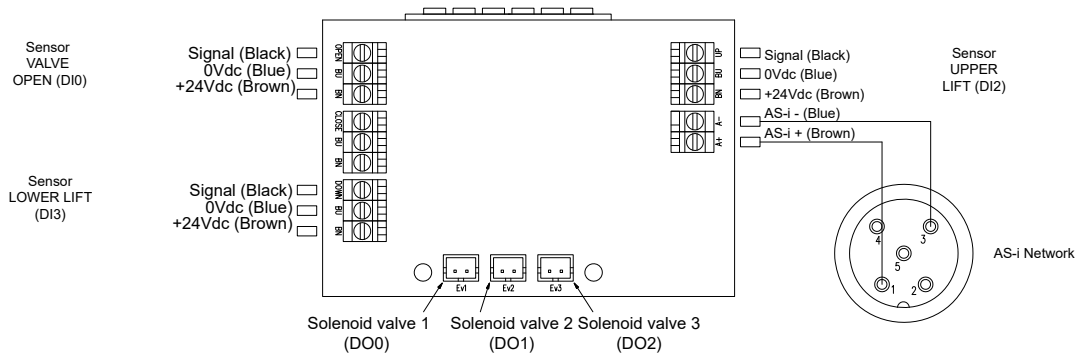

2 PNP sensors with 1 solenoid valve normally closed for BBZS5

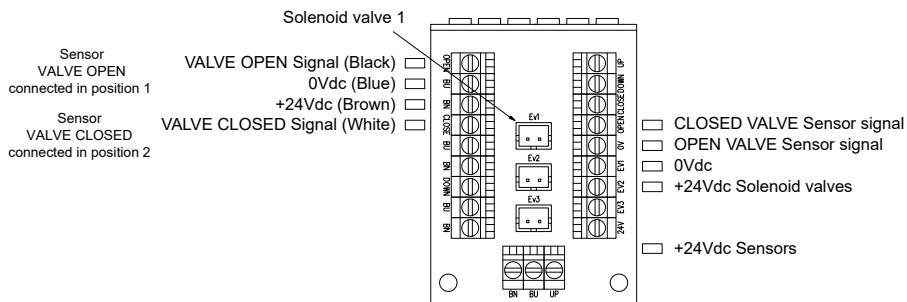

4 Checking / Unpacking / Lifting

1. CHECK:

- Make sure the control unit shows no signs of damage caused during transport and that it corresponds with the order;



2. UNPACKING:

The control unit packaging is made up of cardboard, wood and plastic.

The control unit is primarily made from plastic materials. The gaskets are usually made from elastomers.

Disposal must be in compliance with local legislation.



3. VALVE LIFTING:

Exercise caution when lifting the control unit.



WARNING!

Before lifting, make sure there are no disassembled or separate parts which could fall off causing injury to persons and damage to the valve.



4. WAREHOUSING:

Avoid storing the control unit in a damp, dusty, wet or excessively hot place. Avoid areas subjected to strong vibrations.

The permitted storage temperature is between -10° and + 25°C.

5 Installation of the Giotto Top

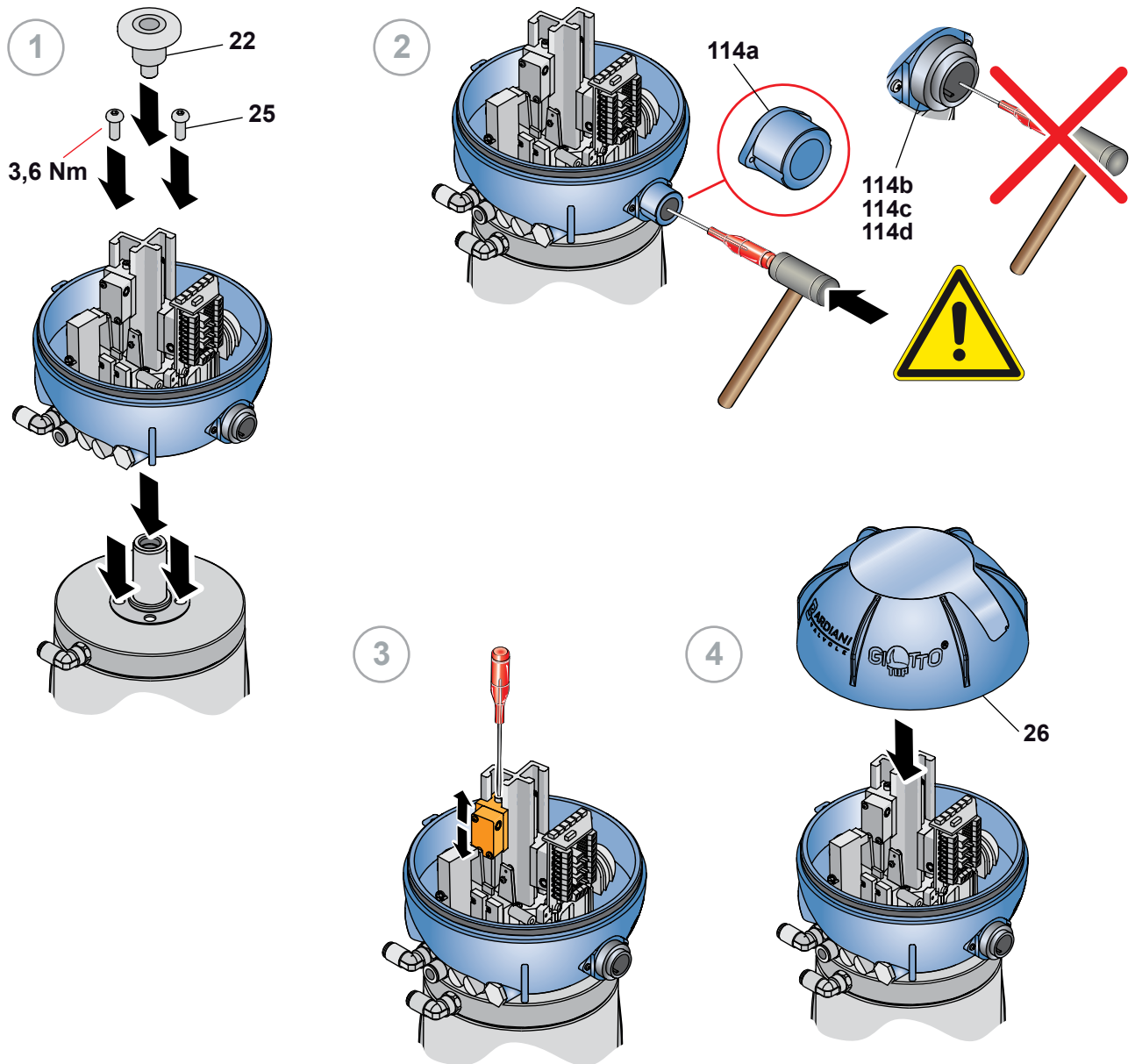

WARNING

Always make sure that all wires are connected and securely fastened to the terminals and that the solenoid valves, solenoid valves support, AS-i card and LED terminal block (when present) and any other parts inside the Giotto Top are well assembled and secured.



WARNING

Always make sure that the electrical and pneumatic connections are disconnected when carrying out operations on the Giotto Top.

External inductive sensor installation

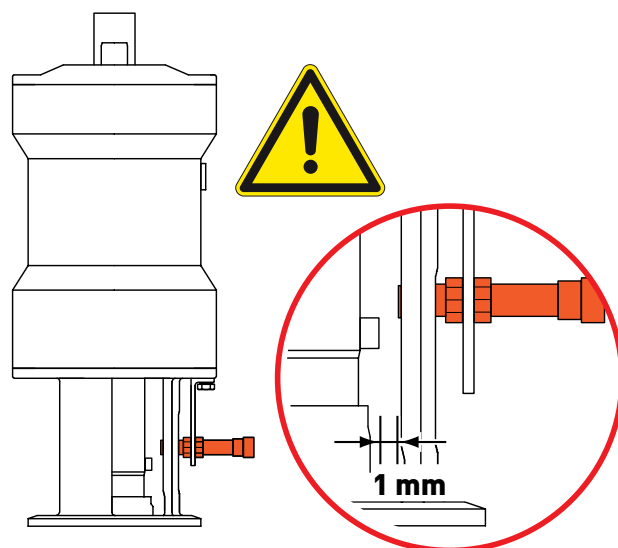
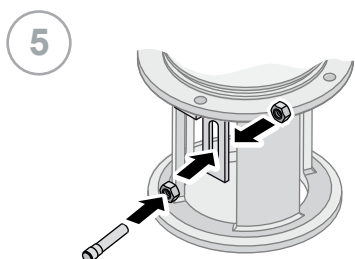
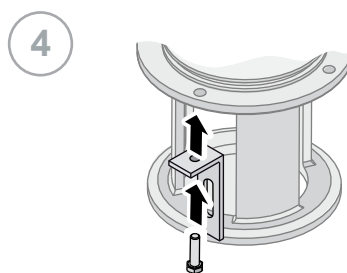
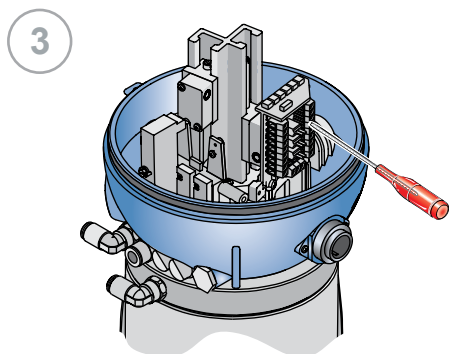
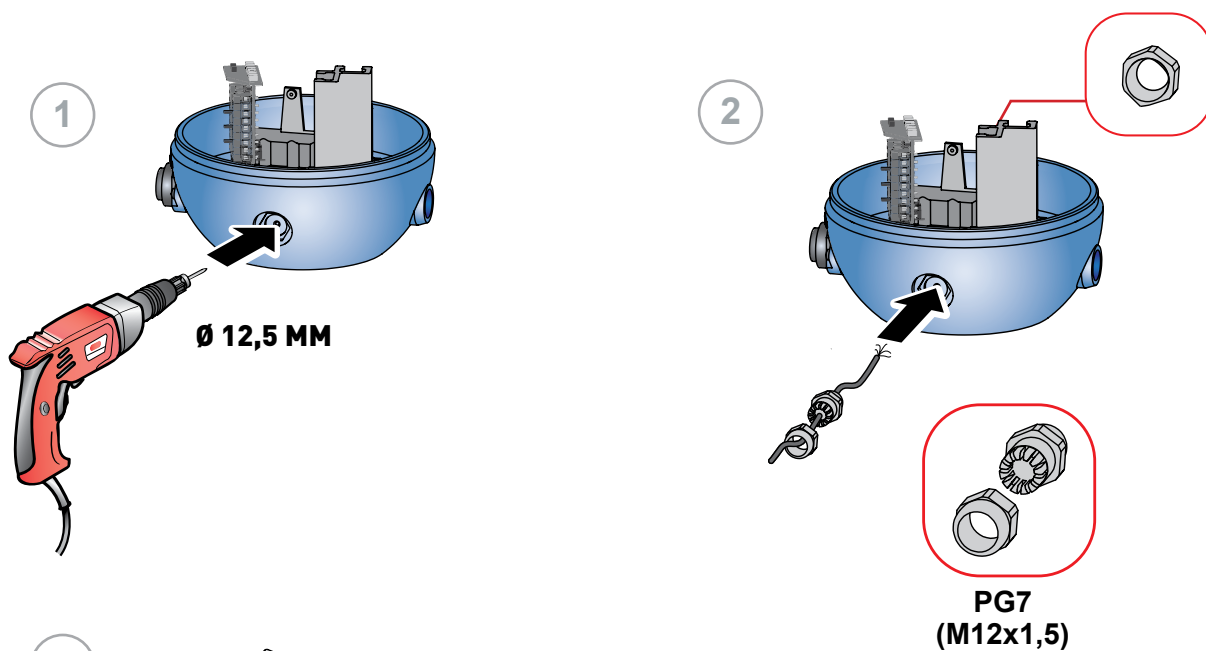

Sensor adjustment:

- Activate the upper lift and secure the sensor in place so that it detects the presence of the cam.
- Close the valve and check that the sensor is deactivated.

Sensor position for reading valve status

Butterfly / Ball valve

Valve not activated

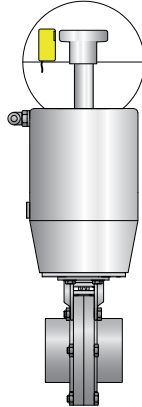

Valve activated

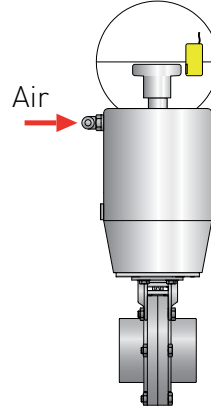

Double seat

Valve closed

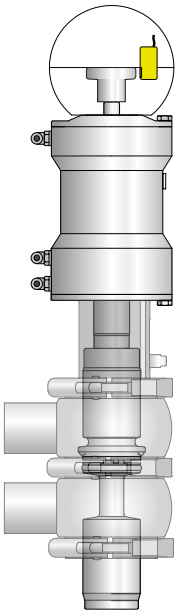

Valve open

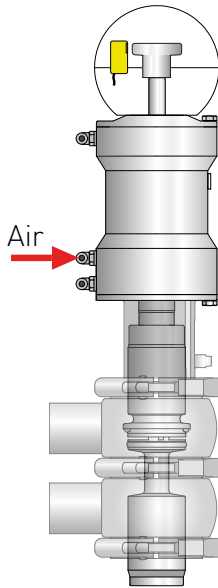

Upper lift reading

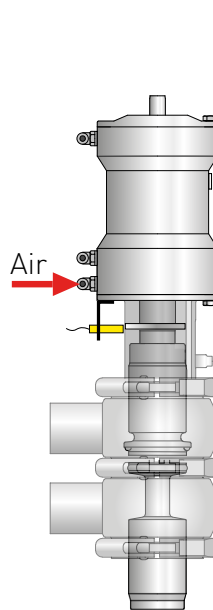

Lower lift reading

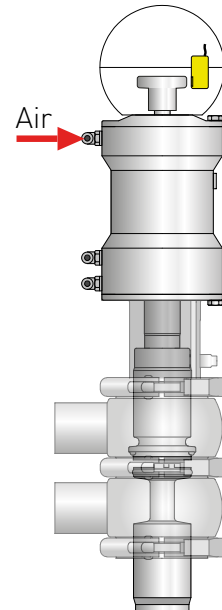

Single seat tank bottom valve BBZOG

Valve closed

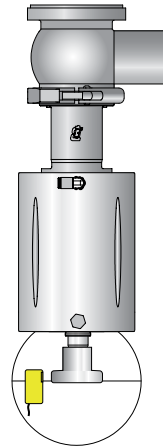

Valve open

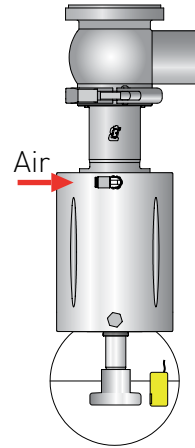

Single seat P7
Single seat tank bottom valve BBZO

Valve closed

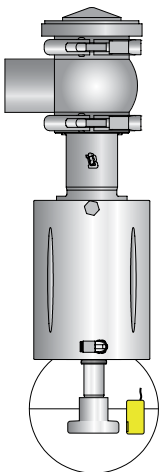

Valve open

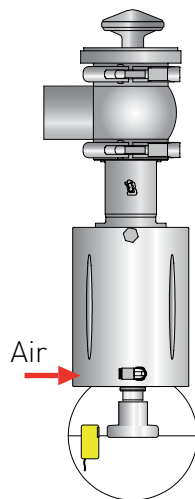

Valve closed

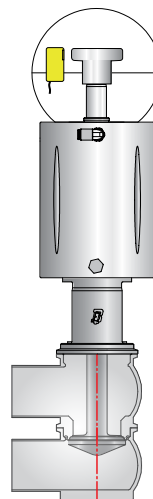

Valve open

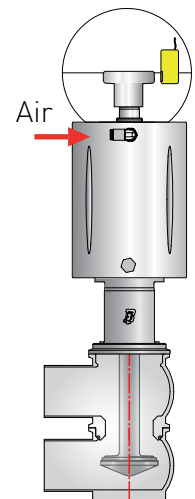

6 Giotto Top Pneumatic connections

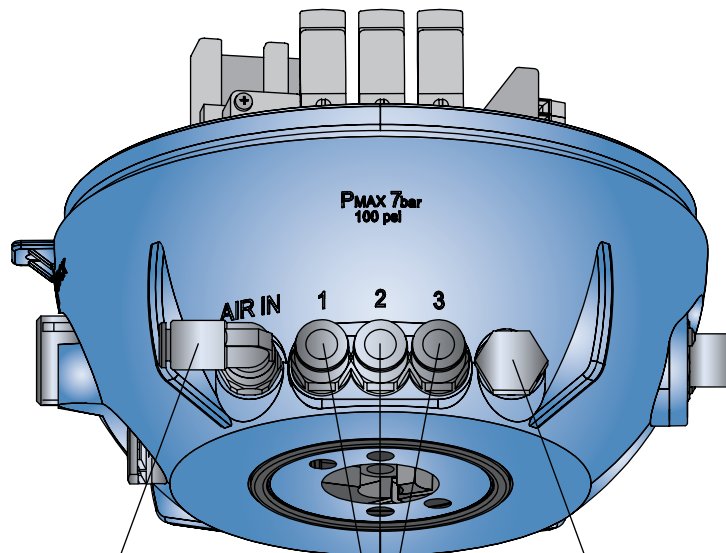
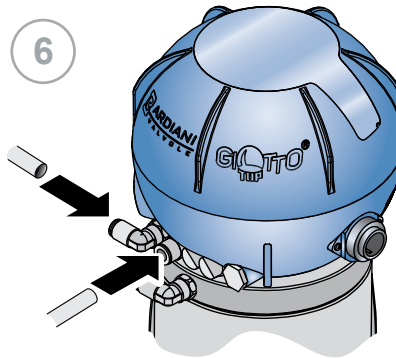

Compressed Air Inlet. Use hose with an external diameter of 6 mm. A 1/4" hose connector can be supplied on request.

Connections for air fitting. Use hose with an external diameter of 6 mm

Air vent



WARNING

Use only pipes with an external diameter of 6 mm.

Cut these pipes with a suitable cutter to avoid damaging the pipe which could lead to Giotto Top malfunctions.

Select a suitable length of pipe which allows the Giotto Top to be removed without unscrewing the anchoring.

Valve with single acting actuator

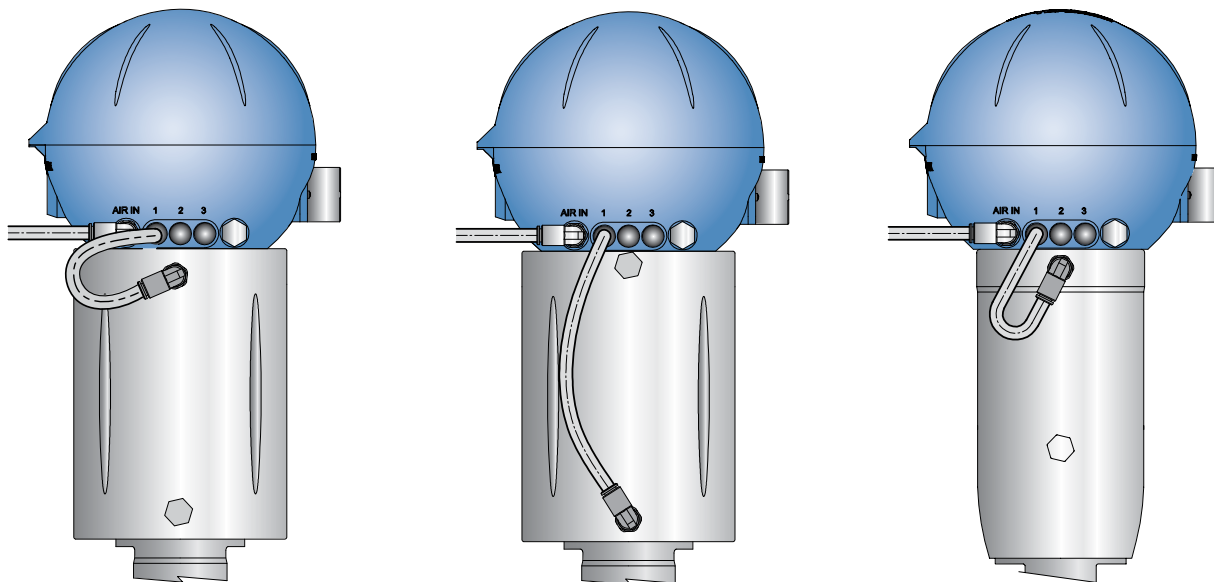

BBZP - BBYP - BBWP

BBZP - BBYP - BBWP

ZVF

Valve with double acting actuator

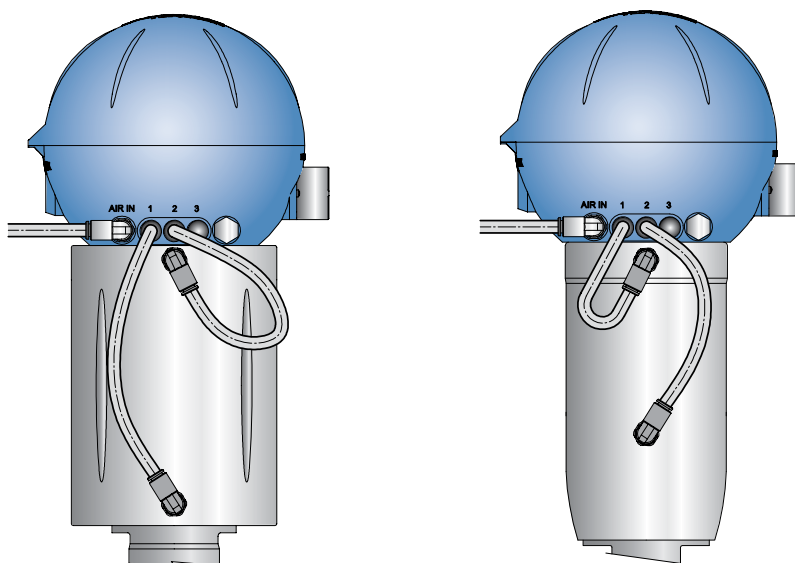

**BBZP - BBYP -
BBZQ**

ZVF

Valve with single acting actuator with Twin Stop

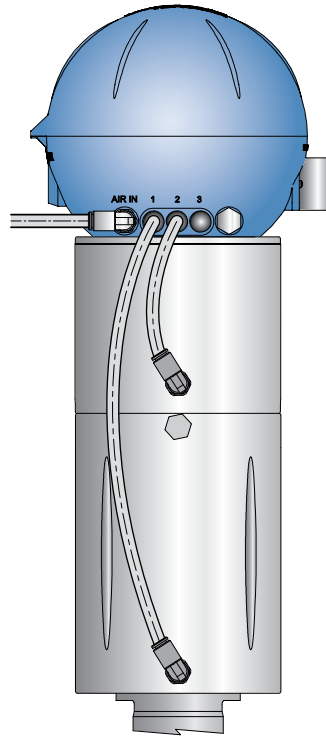

BBZT

Mixproof valve

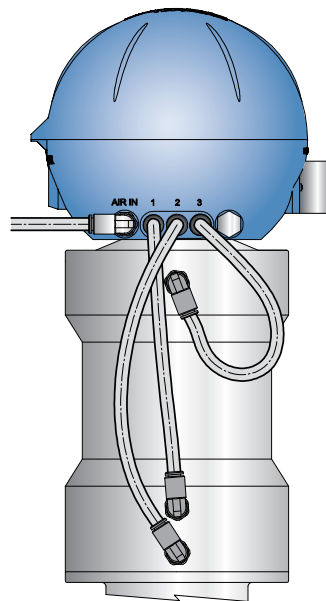

B925 - B935

7 Troubleshooting



PROBLEM	POSSIBLE CAUSE	POSSIBLE SOLUTION
Air leak from solenoid valve support	No gaskets or loose fitting	Check the sealing capacity of the gaskets and tighten the screws
Air leaks in safety valve		
The LED do not come on	Circuit board damaged	Replace the circuit board
	Damaged LEDs	
	Inductive sensors not working	Check the sensor connections in the terminal block and restore if necessary
The solenoid valve does not activate	Damaged solenoid valve	Replace solenoid valve
	Circuit board damaged	Replace the circuit board
	Air supply pressure incorrect	Consult the Technical Data section in the Manual
	Solenoid valve support damaged	Replace solenoid valve support
	Electrical connections not made properly	Check the connections in the terminal block on the electrical board and tighten the screws.
	The solenoid valve manual control has been activated	Reposition the manual control in the default position, see picture above.
The inductive sensors are not working	Inductive sensors damaged	Replace inductive sensors
	Electrical connections not made properly	Check the connections in the terminal block on the electrical board and tighten the screws.
	Distance between the cam and the inductive sensors greater than 1.5 mm.	Check the centring of the Giotto and the fastening to the double guide
	The cam is not present	Secure the cam and check the position of the sensors

PROBLEM	POSSIBLE CAUSE	POSSIBLE SOLUTION
LED terminal block with red light	Valve open sensor reading simultaneously with another sensor	Check the position of the sensors
	Circuit board damaged	Replace the circuit board
	Sensor damaged	Replace the sensor
	+ 24Vdc presence on OPEN and/or CLOSED terminals	Check the electrical connections between the control unit and the electrical panel
AS-i card with flashing red/green light	AS-i card damaged	Replace the AS-i card
AS-i card with red light	Valve open sensor reading simultaneously with another sensor	Check the position of the sensors and adjust if necessary Check the sensors are working properly and replace if necessary
	Communication error	Check the address of the AS-i card and reprogram it if necessary. Check the AS-i network is working properly. Replace the AS-i card

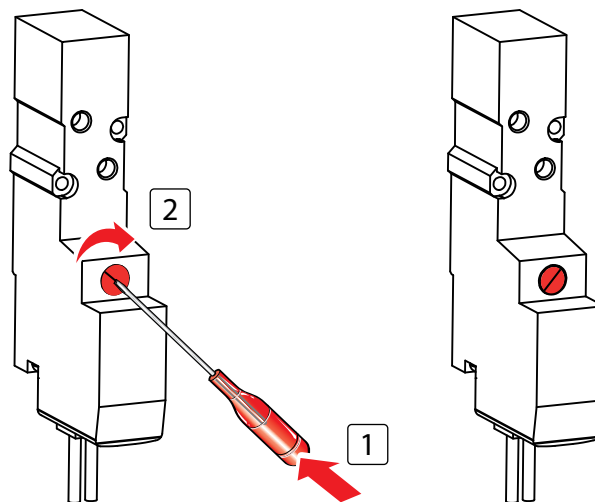
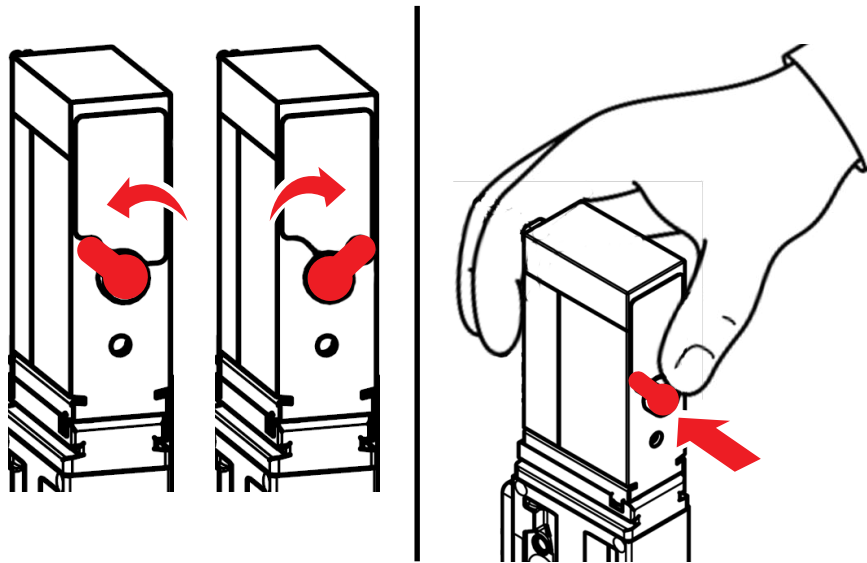

8 Cleaning



1. PRECAUTIONS

The system in which the control unit is installed must be cleaned by expert personnel in observance of the following:

- Use only non-abrasive and non-aggressive detergents compatible with the materials which make up the control unit.
- Observe the instructions provided by the detergent suppliers and adhere to the recommended concentrations.
- Always wear protective safety glasses and gloves.



2. CLEANING

If detergents or cleaning agents containing acids or alkaline substances are used, always make sure the control unit is rinsed immediately with clean water.

Never direct high-pressure jets of water at the control unit.

Pay particular attention to those areas where there are orifices or openings.



Always make sure that the electrical and pneumatic connections are disconnected when carrying out operations on the control unit.

9 Disposal



At the end of its service life, the device must be recycled in accordance with the legislation in force in the country of valve use.

Any hazardous residues must be taken into consideration and adequately handled.

The control unit is made up of: elastomers (gaskets), plastic (control unit) and electrical components (terminal board, solenoid valves, sensors).

Adhere to the following steps before disconnecting the control unit and refer to the heading "General Maintenance".

- Make sure that the line on which the control unit is installed is not in operation
- Disconnect the air supply
- Disconnect the electrical supply
- Remove the control unit from the valve
- To dismantle the control unit, refer to the heading "Disassembly"

10 Maintenance



1. PRECAUTIONS

When used correctly, the control unit does not need any special maintenance.

Any repair work must be carried out by authorized personnel only, making sure that the electrical and pneumatic power supplies have been disconnected before carrying out any operation on the control unit.



Always make sure that the electrical and pneumatic connections are disconnected when carrying out operations on the control unit.



2. REPLACING WORN PARTS

Should it be necessary to replace any component of the control unit, contact Bardiani Valvole S.p.A. to purchase the necessary spare part as the use of any products not supplied by us may compromise correct valve operation or constitute a hazard for personnel.



WARNING

Each time the casing is open, make sure that the various cables inside it are repositioned where they do not interfere with cam movement.



2. SPARE PARTS:

Consult the spare parts manual to identify the part which needs replacing.

To request information and order spare parts, contact our After-Sales service

email: service@bardiani.com

Tel: +390525400044

10.1 Giotto Top Control unit

NO.	DESCRIPTION
21	Base
21a	Sealing ring
21b	Sealing ring
21d	Double guide
21e	Vent plug
21f	Air coupling
21g	Air coupling
21i	Cap
21k	Terminal block with support
22	Cam
25	Screw
26	Bardiani case
27a	Sensor
27d	Micro-size inductive sensors holder slide
114a	Sleeve for cable gland
114b	7-pole connector
114c	5-pole connector
114d	8-pole connector
192	Solenoid valve
192b	Solenoid valve support
192c	Cap
192d	Solenoid valve gasket
192e	Sealing ring

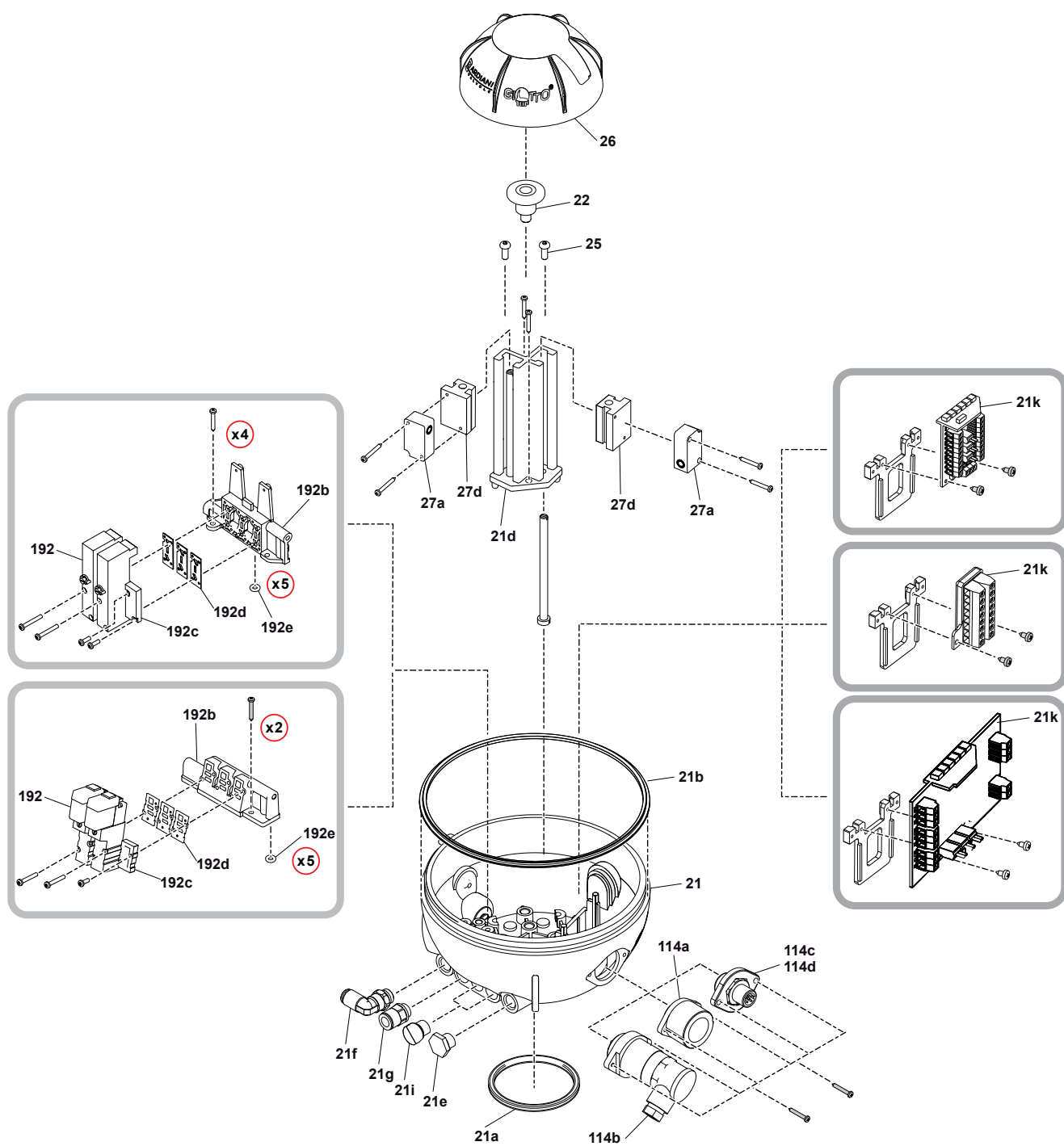

10.2 Disassembly / Assembly of the Giotto Top

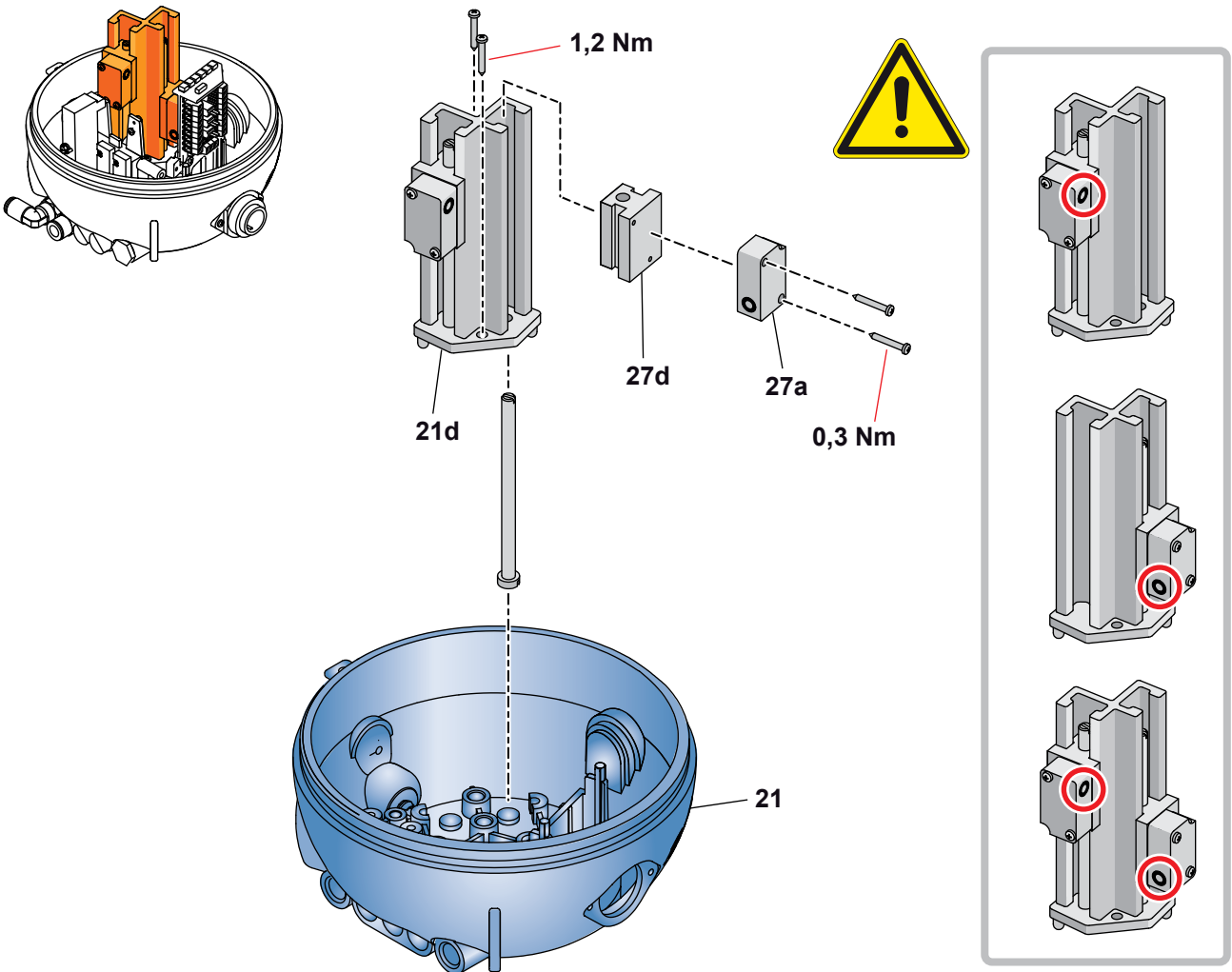
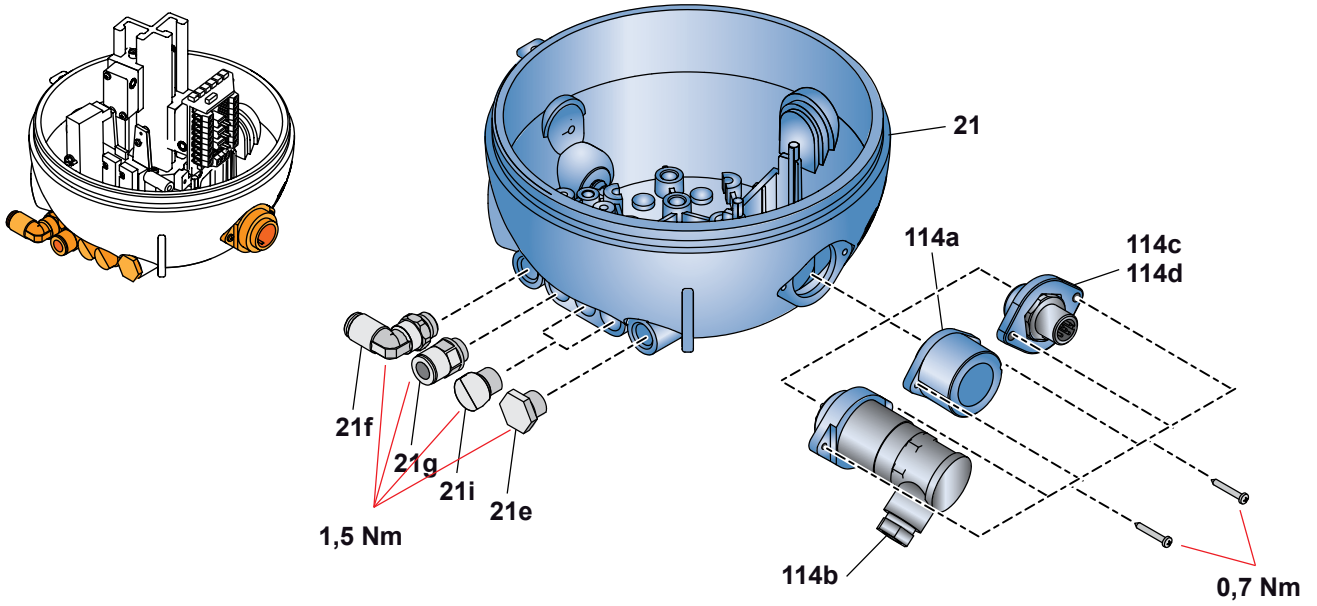

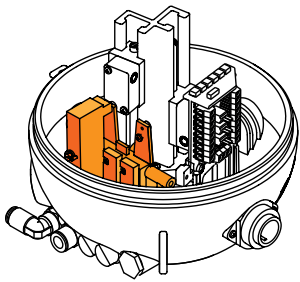

TYPE B

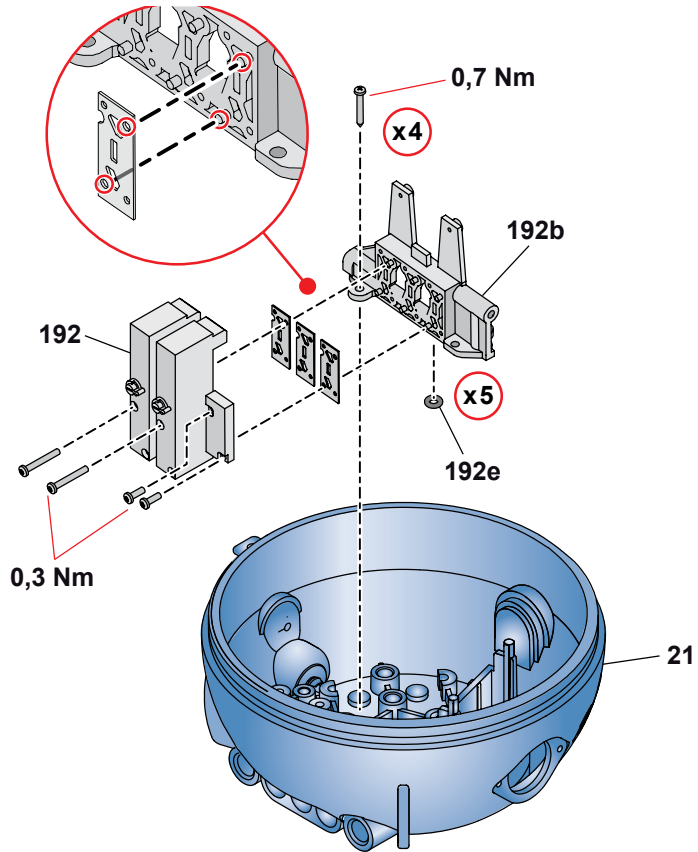

Solenoid valve sequence

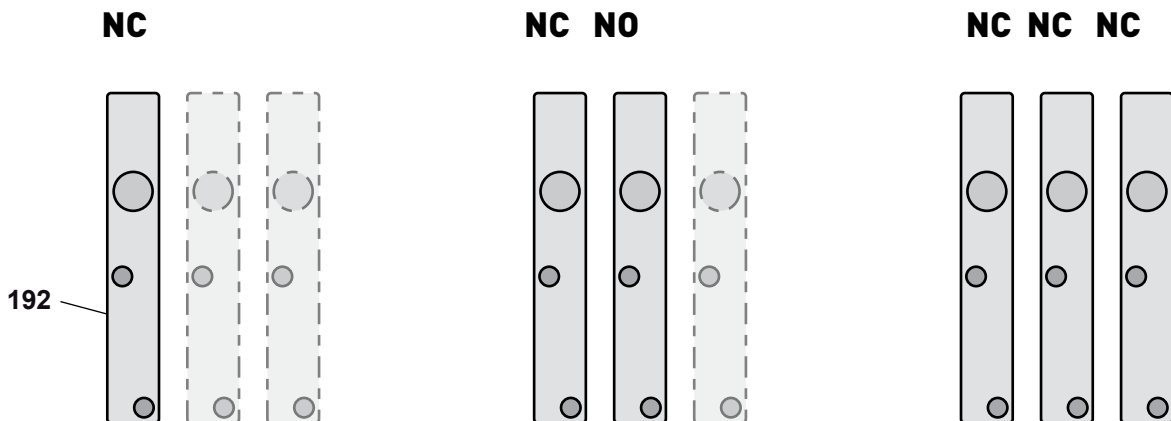

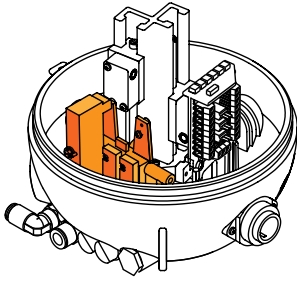

TYPE S

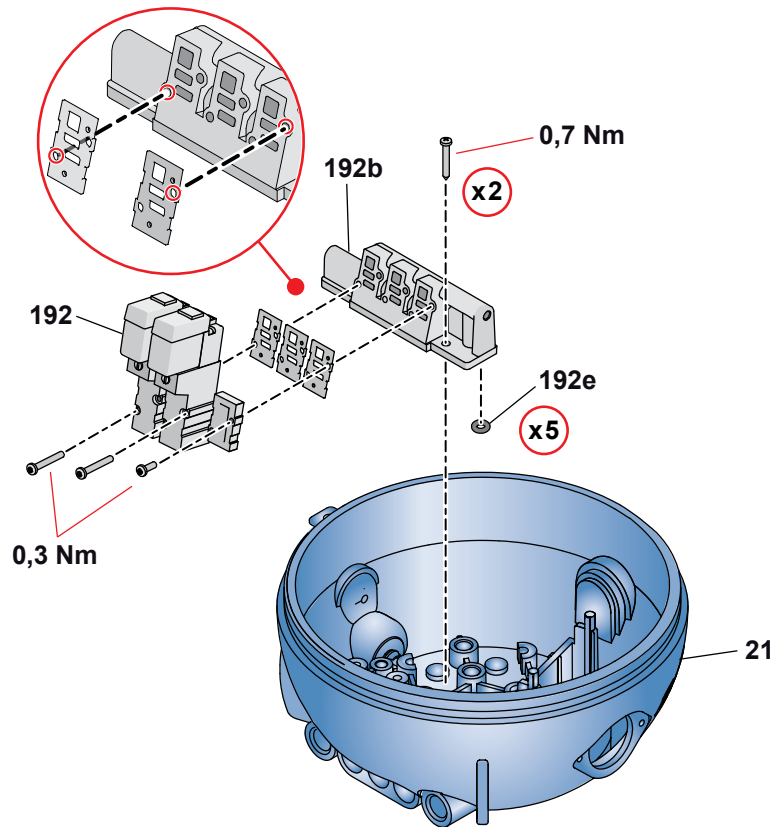

Solenoid valve sequence

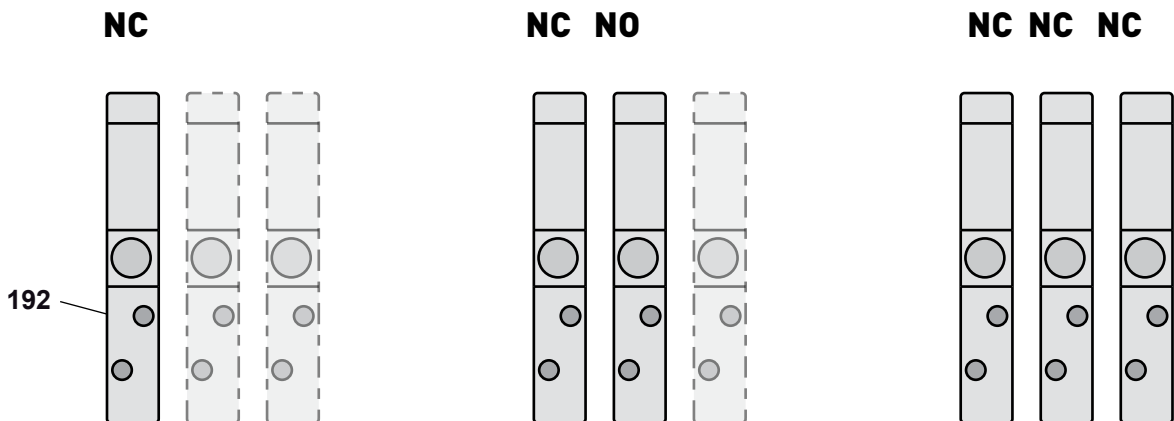

TYPE B - TYPE S

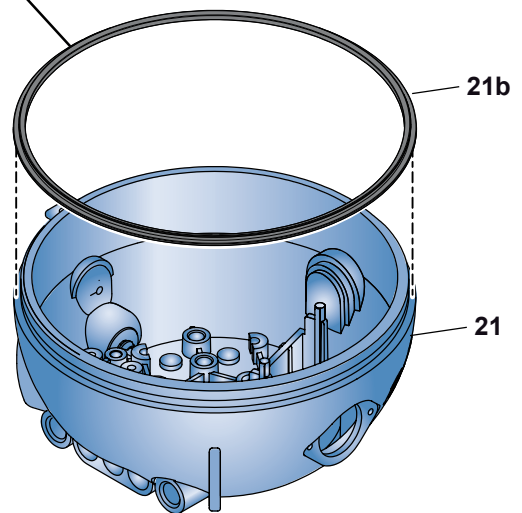
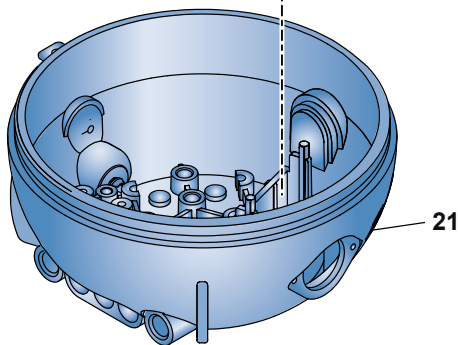
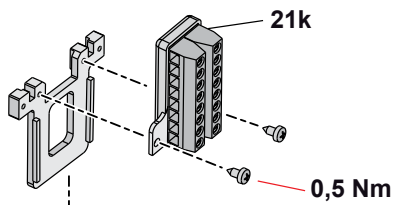
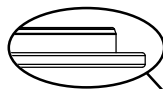
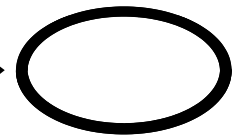
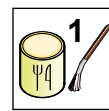
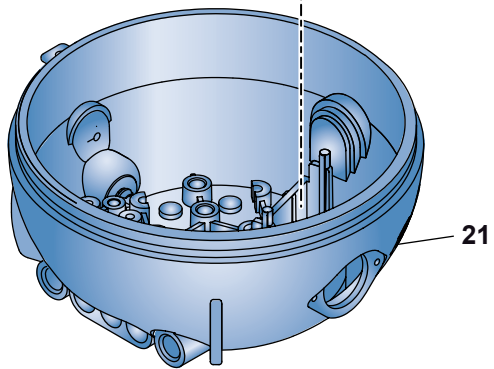
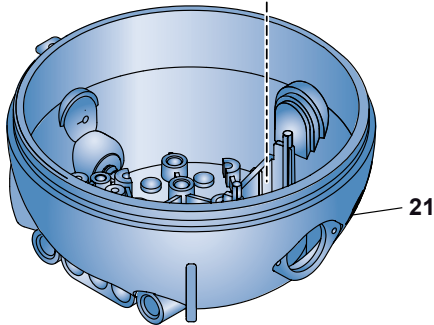
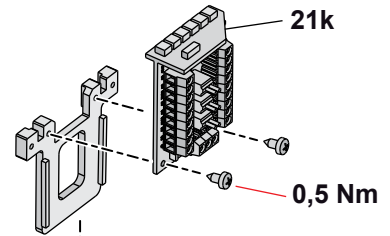
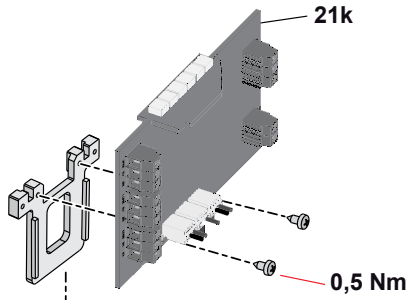
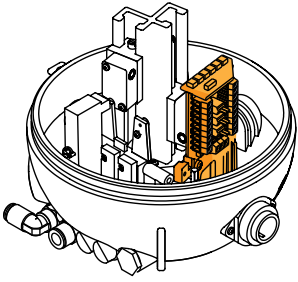

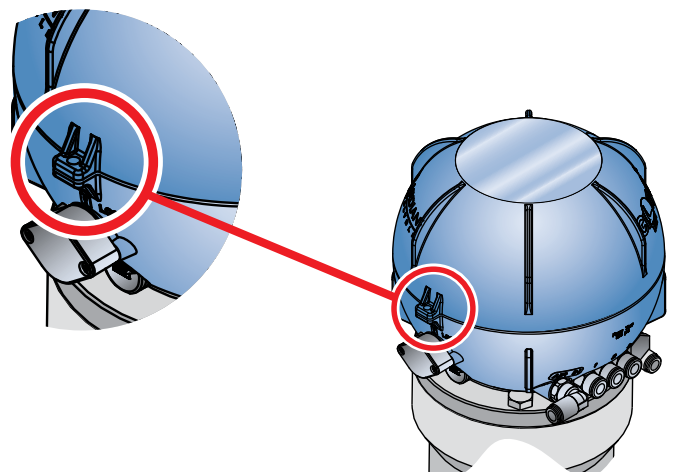
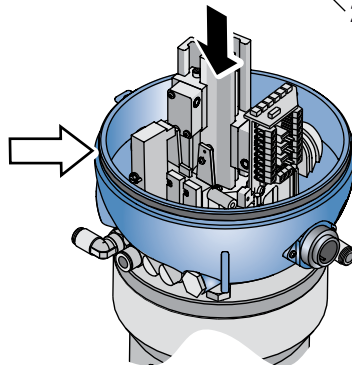
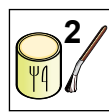
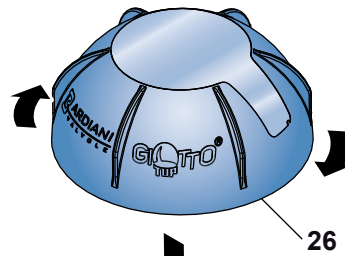
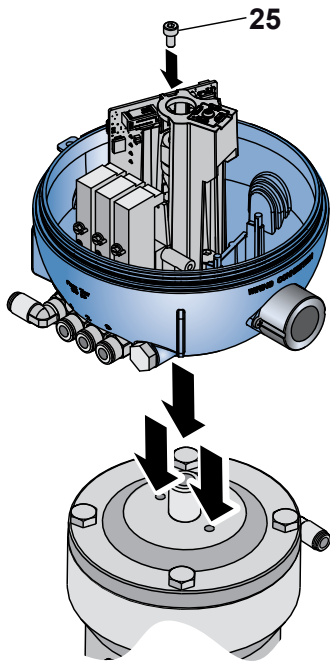

11 Valve complete with control unit

Versione originale in lingua italiana



IT - Dichiarazione CE di
conformità

DICHIARAZIONE CE DI CONFORMITÀ DI UNA MACCHINA

(CE) 2006/42, All. II, p. 1, let. A

BARDIANI VALVOLE S.p.A.

Via G. di Vittorio 50/52 – 43045 Fornovo di Taro (Pr) – Italia

Dichiara

sotto la propria responsabilità che la macchina:

Tipo:	VALVOLE PNEUMATICHE
Modello:	
Numero di serie:	
Funzione:	Movimentazione di fluidi
Anno di costruzione	2016
Riferimenti	

è conforme a tutte le disposizioni pertinenti delle seguenti direttive comunitarie:

(CE) 2006/42 DIRETTIVA MACCHINE

(UE) 2014/30 DIRETTIVA COMPATIBILTA' ELETTRONMAGNETICA

e alle seguenti norme armonizzate, norme e/o specifiche tecniche applicate:

EN ISO 12100:2010

REGOLAMENTO (CE) 1935/2004 e successive modifiche e integrazioni per quanto attiene agli acciai ed agli elastomeri a contatto con il prodotto

REGOLAMENTO (CE) 10/2011 e successive modifiche e integrazioni per quanto attiene al PTFE a contatto con il prodotto

Fornovo di Taro

29.09.2016

Emanuela Bardiani
Legale Rappresentante

12 Warranty

1. VALIDITY

Bardiani Valvole's Products are manufactured in compliance with the technical specifications laid out in their "Instruction, Use and Maintenance Manual" and are fully compliant with the directives specifically mentioned in these manuals.

Bardiani Valvole S.p.A. guarantees its own products against any design and/or construction and/or material defects and/or faults for a period of 12 (twelve) months from the date of delivery.

Notification of any Product defects and/or faults must be sent in writing to Bardiani Valvole S.p.A. within 8 (eight) days from their detection, providing adequate documentation of the defect/fault encountered as evidence.

Services provided in the warranty period shall not result in an extension of the warranty beyond the stipulated 12 (twelve) month period, as this warranty validity period is to be considered mandatory.

2. CONTENTS OF THE WARRANTY

Notwithstanding and without prejudice to the rights of the Buyer, which may be acknowledged by applicable law, this warranty is to be intended as limited, at the discretion of Bardiani Valvole S.p.A., to the repair and/or replacement of the Product and/or part of the Product and/or its components which is/are found to be defective due to design and/or manufacturing and/or material faults.

- In the event of repair and/or replacement of the Product and/or any one of its parts and/or components, any returned item/s shall become the property of Bardiani Valvole S.p.A and the relative shipping costs shall be at the expense of Bardiani Valvole S.p.A.
- Bardiani Valvole S.p.A., shall be under no obligation to compensate for any immaterial and/or indirect damages and shall in no way be held liable for consequential damages and/or losses, such as (by way of example only), damages due to loss of business, contracts, opportunities, time, production, profits, goodwill, image etc..
- No retailer or distributor or dealer or agent or representative or employee or person appointed by Bardiani Valvole S.p.A. is authorized to make any amendments and/or integrations and/or extensions to this warranty.

3. EXCLUSIONS FROM THE WARRANTY

Elastomers are expressly excluded from this warranty.

This warranty does not cover design faults emerging whenever a Product is manufactured by Bardiani Valvole S.p.A. based on designs and/or technical specifications provided by the Buyer.

Application of this warranty also excludes:

- faults and/or defects resulting from incorrect and/or unsuitable and/or improper transport for the Product,
- faults and/or defects resulting from installation of the Product which fails to observe the indications provided in the "Instruction, Use and Maintenance Manual" or in any case caused by incorrect and/or unsuitable and/or improper installation,
- faults and/or defects resulting from use and/or maintenance operations and/or storage of the Products which fail to observe the prescriptions provided in the "Instruction, Use and Maintenance Manual" or in any case which are incorrect and/or unsuitable and/or improper;
- faults and/or defects in the Product and/or its parts and/or its components;
- faults and/or defects in the Product and/or its parts and/or its components for work and/or repairs being carried out by unskilled staff or staff that has not been authorised by Bardiani Valvole S.p.A.;
- faults and/or defects in the Product and/or its parts and/or its components due to it/them being dropped and/or banged and/or dented and/or misused and/or tampering and/or breakage and/or accidents or in any event due to negligence and/or carelessness and/or neglect by the Buyer and in general for any causes not attributable to design and/or manufacturing and/or material defects;
- faults and/or defects in the Product and/or its parts and/or its components caused by other events outside the control of Bardiani Valvole S.p.A. or determined by force majeure or mishap.

13 Recommendations

- 1.** Consultation of the "Instruction, Use and Maintenance Manual" is mandatory prior to the installation, use and maintenance of all Products. All the information, indications, specifications, technical details provided herein are based on test data which the Manufacturer Bardiani Valvole S.p.A. holds to be reliable nevertheless the above is not deemed to be assumed as fully exhaustive inasmuch as not every possible use has been envisaged.
- 2.** All the illustrations and drawings provided are to be intended as indicative and therefore not binding, the illustrations being for presentation purposes only.
- 3.** Being as the conditions of Product use and applications cannot be controlled by Bardiani Valvole S.p.A., the Purchaser must ascertain suitability of the use he intends to make of the products beforehand and assume all risks and liabilities which may result from the same.
- 4.** Customer is strongly advised to consult Bardiani Valvole S.p.A.'s technical-commercial collaborators to request any specific information concerning the technical characteristics of the Products.
- 5.** The information provided in this manual refers to the standard products manufactured by Bardiani Valvole S.p.A. and therefore cannot be assumed to apply to customized products as well.
- 6.** Bardiani Valvole S.p.A. reserves the right to amend and/or integrate and/or update the data and/or information and/or technical details relative to products at any time and without prior notice. Please visit the website, www.bardiani.com, where the latest updated of the "Instruction, Use and Maintenance Manual" can be found".
- 7.** The content and validity of the warranty covering Bardiani Valvole S.p.A products are dealt with in the relative section in the "Instruction, Use and Maintenance Manual" which constitutes an integral part of the products themselves.
- 8.** The content and validity of the warranty covering the Products of Bardiani Valvole S.p.A are dealt with in the relevant section in the "Instruction, Use and Maintenance Manual" which constitutes an integral part of the Products themselves.

NOTES

NOTES

Bardiani Valvole S.p.A.
via G. di Vittorio, 50/52 - 43045 Fornovo di Taro (PR) - Italy
tel. +39 0525 400044 - fax +39 0525 3408
bardiani@bardiani.com - www.bardiani.com