

Instruction, Use and Maintenance Manual



**DOUBLE SEAT VALVE FOR
PIG SYSTEM**

**B93J - B93JPG -
B93JPG REVERSE**

Bardiani Valvole S.p.A.

via G. di Vittorio, 50/52 - 43045 Fornovo di Taro (PR) - Italy

tel. +39 0525 - Fax 0525 3408

bardiani@bardiani.com - www.bardiani.com

MANUAL REVISION	DATE

INDEX

INTRODUCTION	4
1 Safety, Warning and Mandatory Signs	5
1.1 Operator training	8
2 Safety	9
2.1 General safety warnings	9
2.2 Electrical connections	9
3 Technical data	10
4 Checking / Unpacking / Lifting	11
5 Installation	13
6 Operation	17
7 Troubleshooting	18
8 Cleaning	19
9 Disposal	22
10 Maintenance	23
10.1 General maintenance	23
10.2 Scheduled maintenance	24
10.3 Tools useful for Disassembly/Reassembly	25
10.4 Mixproof valve B93J - B93JPG	26
10.5 Disassembly of the B93J - B93JPG	28
10.6 Assembly of the B93J - B93JPG	44
11 CE certificate	61
12 2D diagram B93J	62
13 2D diagram B93JPG	63
14 2D diagram B93JPG Reverse	64
15 Warranty	65
16 Recommendations	66

INTRODUCTION

This "Instruction, Use and Maintenance Manual" has been prepared to provide guidance and recommendations to assist qualified skilled technicians in the understanding, running and maintenance of the Products supplied.

It forms an integral part of the Products supplied and must be read prior to any installation, operation and/or maintenance of all types of valves provided.

This manual must be saved for future reference and be kept readily available at the unit.

With regards to the use of valves compliant with EU Directive 2014/34/UE (ATEX), consultation of a specific manual is mandatory.

The essential characteristics of all types of valves described herein being consistent, the Manufacturer reserves the right to alter and or complement and or update at any time and with no obligation to notify so in writing, the data and or information relevant to the use of the valves described in this "Instruction, Use and Maintenance Manual".







A constantly updated version of this "Instruction, Use and Maintenance Manual" is available at the Manufacturer's website www.bardianivalvole.it.





Under no circumstance shall the Manufacturer be held liable for consequences resulting from failure and or improper use of the instructions contained in this Manual and relating to the installation, operating, maintenance and storage of the products.



All rights reserved.







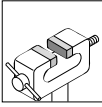
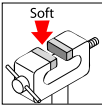

Full or part reproduction, transfer and or recording of any part of this "Instruction, Use and Maintenance Manual" by all means, whether it be electronic, on hard copy, mechanical or any other means or recording or reuse is strictly prohibited without the prior written consent of the Manufacturer and for any use other than that of the Buyer.

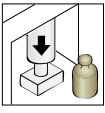
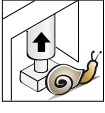
1 Safety, Warning and Mandatory Signs

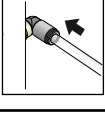
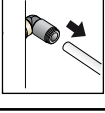
WARNING SIGNS		
Pictogram	Description	Notes
	WARNING General	This tells the person in question that the operation described involves (when not performed in accordance with the relative safety regulations) the risk of personal injury.
	WARNING Hand crushing	Exercise caution in executing the procedure Hand crushing hazard Never touch the moving parts if the actuator is supplied with compressed air
	WARNING Heavy loads	Exercise caution in executing the procedure Heavy suspended loads.
	WARNING Severe burns	Heat emission hazard Very hot surface, risk of severe burns
	WARNING Risk of explosions	Take Care, risk of explosions
	WARNING Loaded Spring Hazard	Pay attention to the loaded spring during disassembly operations

MANDATORY SIGNS (FOR THE OPERATOR IN CHARGE OF MECHANICAL MAINTENANCE AND THE OPERATOR IN CHARGE OF ASSEMBLY/DISASSEMBLY)		
Pictogram	Description	Notes
	OBLIGATION General	Special instructions must be followed to avoid injury to persons.
	PROTECTIVE GLOVES	Protective gloves must be available for handling objects which could cause hand injuries or when there is the possibility of coming into contact with harmful substances..
	HARD HAT	Hard hats must be available when lifting heavy parts.
	FOOTWEAR	Use safety footwear to protect against injuries caused by falling objects during maintenance operations (particularly when dismantling parts).
	SUITABLE CLOTHING	Suitable clothing such as overalls. It is strictly prohibited to wear clothes with large flapping sleeves and/or other loose items which could easily get caught up in machine parts.
	SAFETY GLASSES	Protective glasses must be available when there is the possibility of contact which harmful substances which could cause eye injuries.

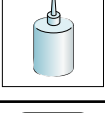
OPERATING SIGNS		
Pictogram	Description	Notes
	SKILLED PERSONNEL	Dismantling/Assembling and maintenance operations must be carried out by expert technicians only.
	NOTE	Follow the indicated note with care
	ENVIRONMENTAL NOTE	Follow the regulations in force in the country of used governing waste disposal.
	CLAMP	Use of a clamp
	CLAMP WITH SOFT JAWS	Use of a clamp with jaws made from soft material

OPERATING SIGNS		
Pictogram	Description	Notes
	PRESS	Use of a press
	PRESS (release)	Use of a press Gradual release of the pressure force
	ELECTRICAL CONNECTION	Electrical connection to the control unit (consult the relative instruction manual).
	ELECTRICAL DISCONNECTION	Electrical disconnection from the control unit (consult the relative instruction manual).
	PNEUMATIC CONNECTION	Connection of the air to the valve.
	PNEUMATIC DISCONNECTION	Disconnection of the air from the valve
	APPLICATION OF FOODSAFE GREASE	Use CIP-FILM grease or similar
	APPLICATION OF FOODSAFE GREASE	Use FOODLUBE Multi-paste grease or similar
	APPLICATION OF MULTIPURPOSE GREASE	Use AGIP GREASE MU EP 2 SE or similar
	THREADLOCK APPLICATION	Use SPEED BOND M500 threadlock or similar
	ASSEMBLY / DISASSEMBLY SEQUENCE	Sequence of assembly disassembly operations
	OPTIONAL	

1.1 Operator training



Tutte le persone che dovranno operare sulla valvola devono avere la qualifica per svolgere le mansioni di manutenzione sulla valvola.

Devono essere informati sui possibili pericoli e devono osservare le istruzioni sulla sicurezza riportate in questo manuale.

Consentire solo a personale qualificato di agire sui componenti elettrici.

2 Safety

2.1 General safety warnings



Intended use

Bardiani valves have been exclusively for moving fluids.

Prohibited use

The valve must not be used:

- for any operations different to those described under the heading “Intended Use”,
- for handling fluids different to the type specified by the manufacturer and indicated in the valve's technical data;
- for moving fluids at different pressures to those envisaged by the manufacturer and indicated in the valve's technical data.

Limitations on valve use

It is forbidden to:

- use the valve in a construction configuration different to the one envisaged by the manufacturer.
- use the valve where there is a risk of explosion and/or fire, unless envisaged by the manufacturer (if the valves are certified in accordance with Directive 2014/34/EU, please refer to the ATEX Manual)-;
- integrate other systems and/or equipment which were not considered by the manufacturer during the executive design phase,
- use the valve for purposes other than those specifically envisaged by the manufacturer.
- During the lift and sterilization phases, high temperature liquids may come out of the discharge stub. A suitable exhaust manifold system must be provided.



WARNING

The machine may not be used inside premises where there is a potentially explosive atmosphere or risk of fire unless otherwise stated by the manufacturer (in the case of valves certified in accordance with Directive 2014/34/EU please refer to the ATEX Manual).



BARDIANI VALVOLE S.p.A. declines all liability for installation, use or maintenance which fails to comply with the indications provided in this manual!

2.2 Electrical connections

(see the control unit manual)

3 Technical data

VALVE STRUCTURE DATA	
Maximum pressure	PN10
Maximum seal pressure	See catalogue
Storage temperature	from -10°C to 25°C
Material in contact with the product	AISI 316L (1.4404). Check the resistance to corrosion in relation to products and detergents
Gasket material in contact with the product	EPDM, FKM, HNBR and other gaskets on request. Check compatibility with products and detergents
Surface finish in contact with the product	Ra 0.8 µm. Other finishes available on request

PNEUMATIC ACTUATOR STRUCTURE DATA	
Connectors	1/8" BSP
Pipe dimensions	6 mm external diameter, 4 mm internal diameter
Air pressure	from 6 bar (87 psi) to 8 bar (116 psi)
Air quality	Class 2, 4, 3 ISO8573-1
External material	AISI 304L (1.4307)
Seals	NBR
Noise levels	76 dB
Electrical supply	See Giotto Top

GASKET MATERIALS COMPATIBILITY			
Product	EPDM	FKM	HNBR
Temperature (applications with air)	from -10°C to 140°C	from -10°C to 200°C	from -10°C to 130°C
Caustic soda 2%	60°C	30°C	To be checked
Nitric Acid 2%	60°C	80°C	To be checked
Saturated steam 125°C	Suitable	To be checked	Suitable
Greases	Unsuitable	Suitable	Suitable
Alcohols	Suitable	Unsuitable	Suitable



The valve complies with PED 2014/68/EU directive, with special reference to Annex III, Module A, concerning internal manufacturing checks as indicated in the Conformity Assessment Procedures.

Valves with DN equal or smaller than DN25 are not included in compliance with Article 4, paragraph 3.

Valves designed for use with gases, liquefied gases, gases dissolved under pressure, vapours and also those liquids whose vapour pressure at the maximum allowable temperature is greater than 0,5 bar above normal atmospheric pressure (1 013 mbar) are included within the following limits:

- valves with DN between DN32 and DN100 (included) with group 1 fluids;
- valves with DN125 or bigger with group 2 fluids.

The end user must carry out noise assessment testing once the valve has been installed in the plant.

In the event of any doubt, please contact Bardiani Valvole S.p.A.

4 Checking / Unpacking / Lifting

1. CHECK:

- Check the valve show no signs of damage caused during transport and that it corresponds with the order;
- Check the inside of the valve.



2. UNPACKING:

The valve packaging is made up of cardboard, wood and plastic. The valve is mainly made up of metal materials. The gaskets are usually made from elastomers. Disposal must be in compliance with local legislation.

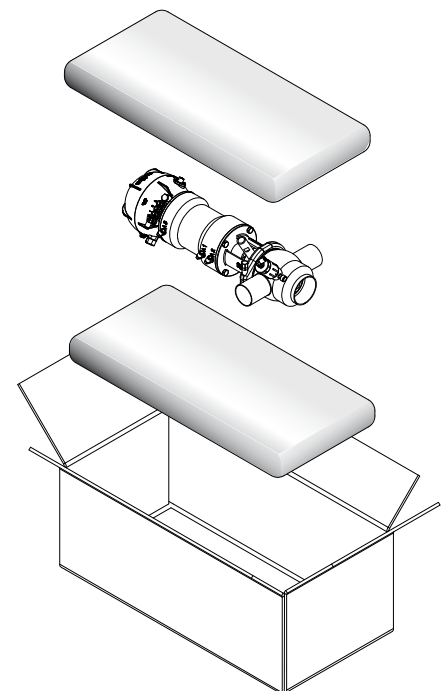
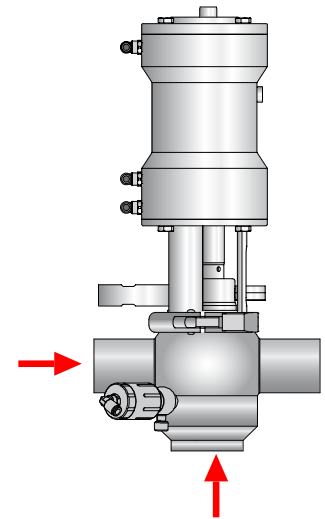



3. VALVE LIFTING:

Take care as to the type of valve you are handling. Based on the size there are different lifting procedures.



CAUTION!

Before lifting the valve, make sure there are no disassembled or separate valve parts which could fall off causing injury to persons and damage to the valve.

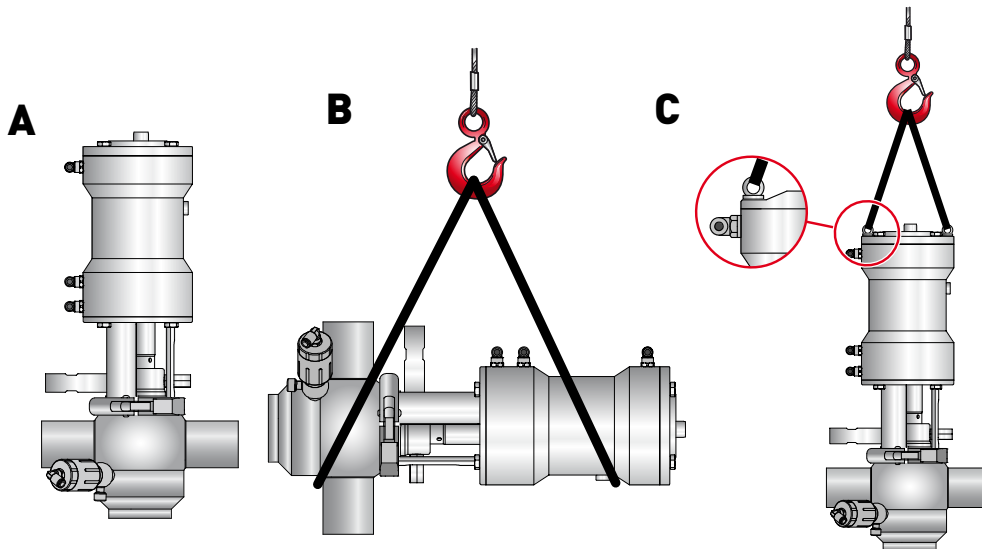

CAUTION!

The figures above are used purely to represent the methods and procedures for hoisting the valves. Handle the device according to the regulations in force in the country of use.

Bardiani Valvole S.p.A. declines all liability for any damage to things and/or injuries to persons caused by improper and/or incorrect hoisting of the valve.

5 Installation



1. ELECTRICAL AND PNEUMATIC ENERGY SUPPLY

- Use expert personnel for installation/uninstallation operations;
- Check that the air pressure and quality are correct (see "Technical Data");
- Check the power supply to the control unit is correct (consult the relative instruction manual).

A = Bottom lift
B = Opening
C = Top lift

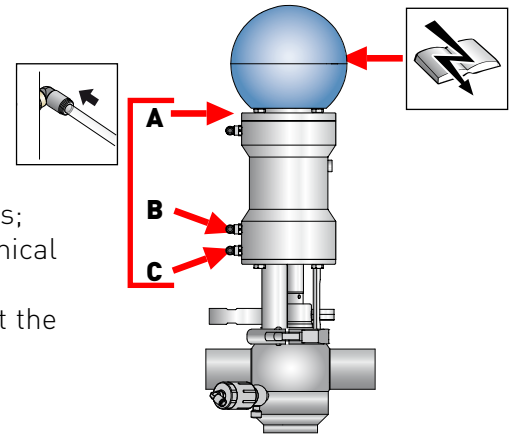

2. REDUCING THE STRESS TO WHICH THE VALVE IS SUBJECTED:

- Vibrations;
- Thermal expansion of the piping;
- Excessive welding;
- Overload.



CAUTION!

The seal seats may become deformed or cause valve malfunctioning.



3. CORRECT DIRECTION OF FLOW:

Flow in the opposite direction to valve closure minimizes water hammer.

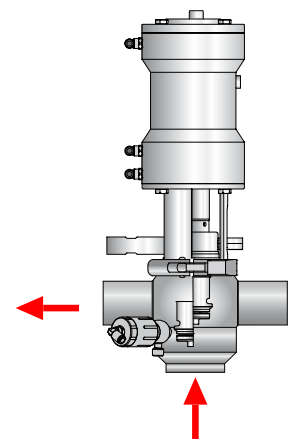
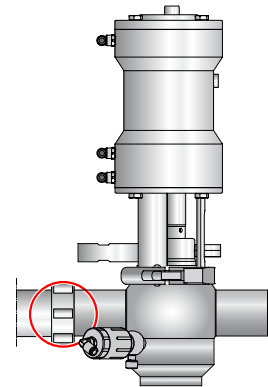

**CAUTION!**

Hand crushing hazard. During operation there is a crushing hazard caused by the discharge stub pipe.

**CAUTION!**

Bardiani Valvole S.p.A. declines all liability for any damage to things and/or injuries to persons caused by any failure to correctly follow the installation procedures.

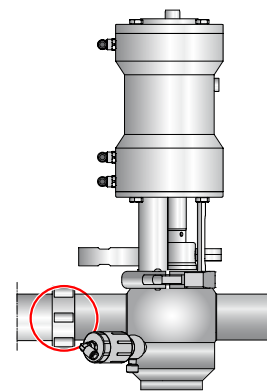
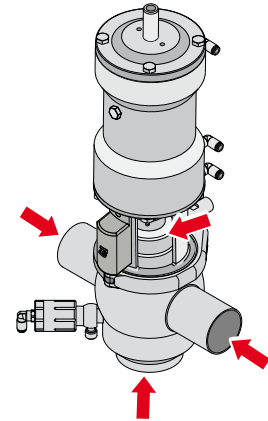
**4. VALVE CONNECTIONS/CONNECTORS:**

If the valve is fitted with connectors, you may proceed with installation. Correctly insert the gaskets and tighten the connectors.

**5. WELDING THE VALVE BODY ONTO PIPING:**

1. Insert air couplings in the central connector.
2. Remove the body from the rest of the valve before proceeding with welding operations.

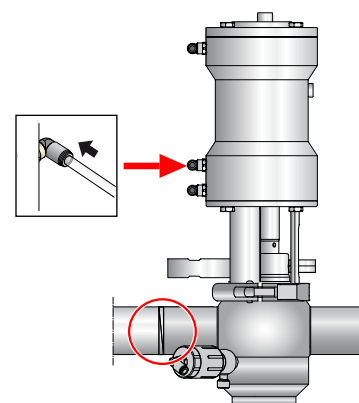

Check before using the valve:
 Supply compressed air in the various A - B - C inputs one by one
 Operate the valve several times to make sure it works properly.

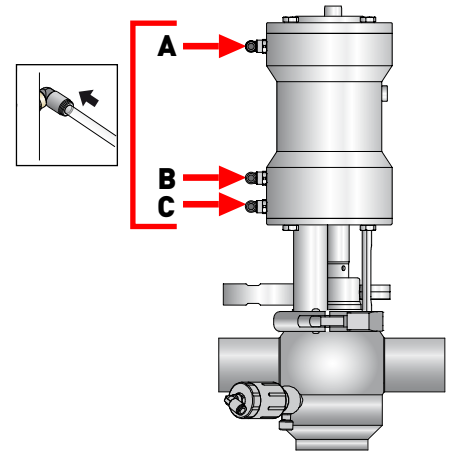

6. MINIMUM MAINTENANCE CLEARANCES:

Make sure there is enough space around the valve for it to be disassembled (with the control unit installed).

DN	B93J - B93JPG
	A (mm)
40	260
50	260
65	260
80	280
100	350
125	400
150	400

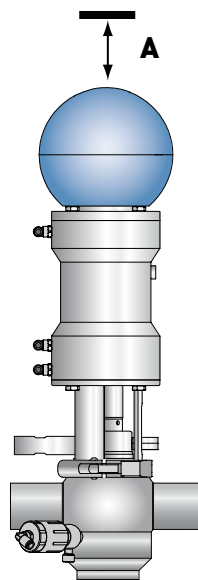

B93J

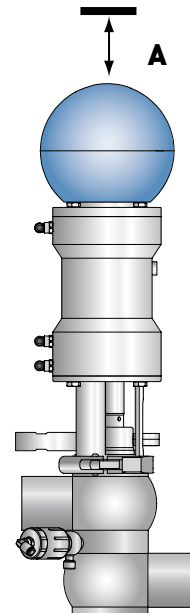

B93JPG

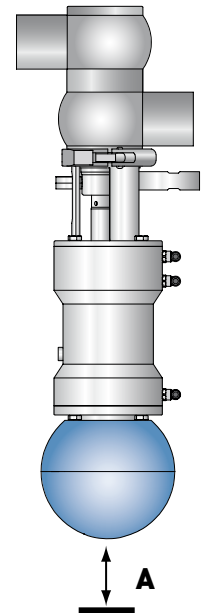

**B93JPG
REVERSE**



CAUTION!

Bardiani Valvole S.p.A. declines all liability for any damage to things and/or injuries to persons caused by any failure to correctly follow the installation procedures.



9. PREPARING THE VALVE FOR INSTALLATION:

To move the valve, first screw in the eye bolts.

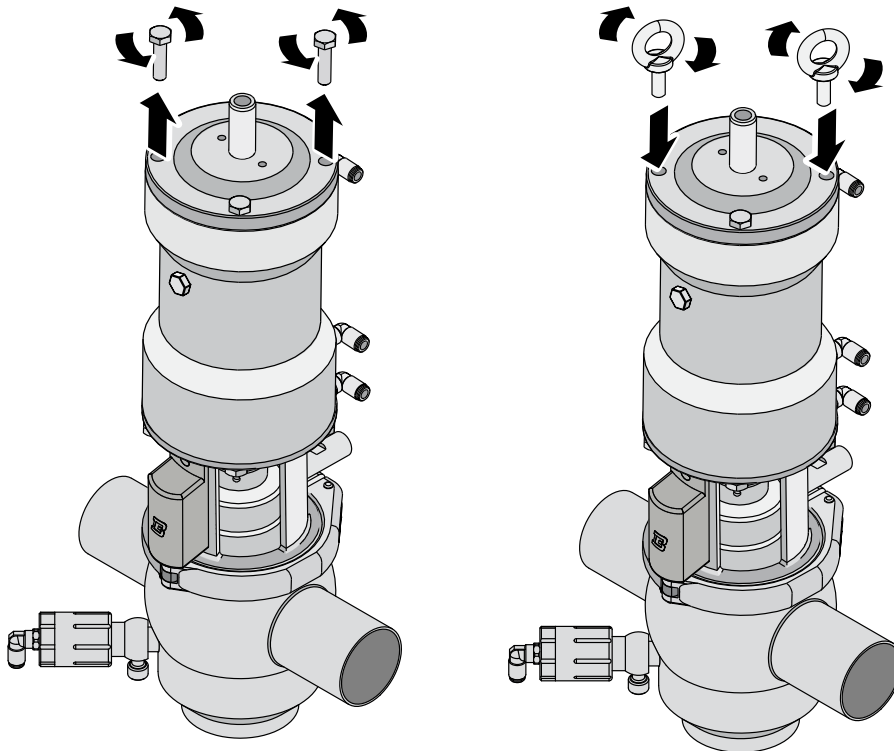

Once valve installation has been completed, remove the eyebolts and put the screws back in

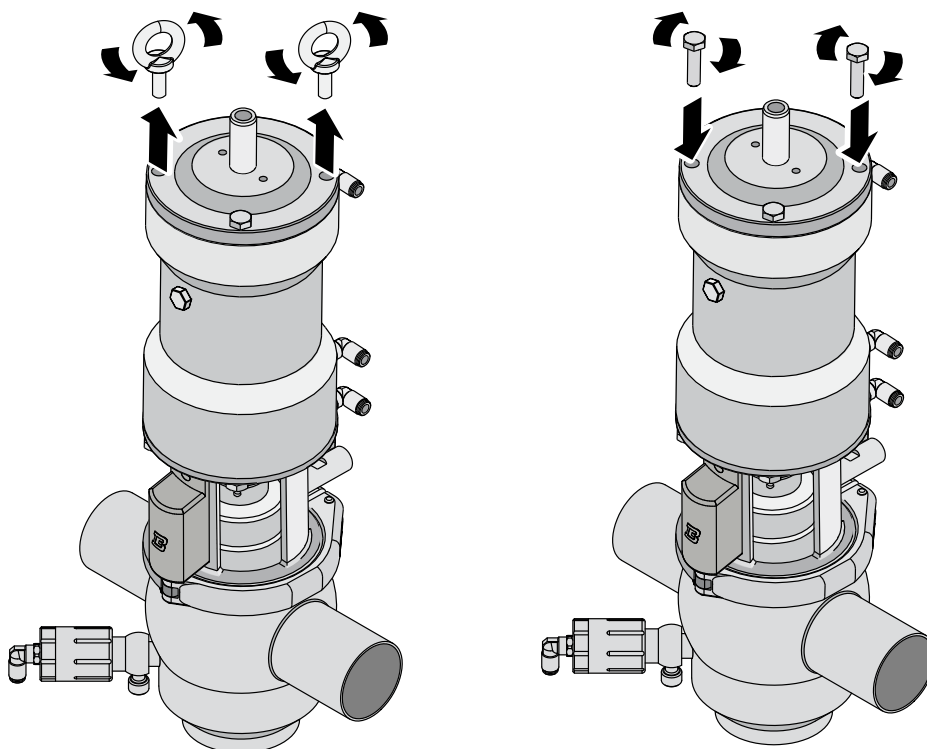

6 Operation



1. VALVE INSPECTION BEFORE OPERATION:

- Supply air to the actuator;
- Power the valve (via the control unit);
- Open and close the valve several times;
- Check that the valve works correctly and accurately.

A = Bottom lift

B = Opening

C = Top lift

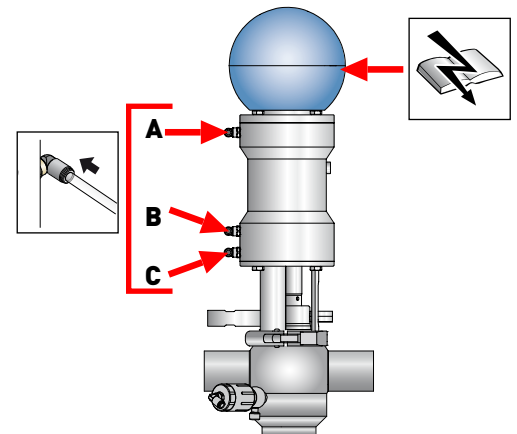

CAUTION!

Hand crushing hazard. During operation there is a crushing hazard caused by the discharge stub pipe.

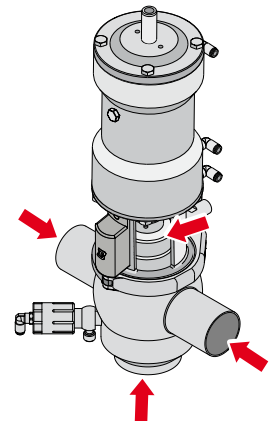

7 Troubleshooting



PROBLEM	POSSIBLE CAUSE	POSSIBLE SOLUTION
External leak	Worn gasket	Replace the seal
Leaks inside the closed valve caused by normal wear		
External leak	Excessive pressure	Replace with a gasket of a different type of elastomer
	Excessive temperature	
Premature leaks inside the closed valve	Aggressive fluids	Modify the operating conditions
	Too many commands active	
Difficulty opening and closing	Incorrect type of elastomer used for the gaskets	Replace with a gasket of a different type of elastomer
	Incorrect positioning of the actuator	Install the actuator correctly
	Impurities in the actuator	Actuator inspection and maintenance
	Incorrect valve body positioning	Disassemble and correctly reposition the valve body

8 Cleaning



1. VALVE CLEANING WITH DETERGENTS:

The system in which the valve is installed must be cleaned by expert personnel in observance of the following:

- Abide by the indicated detergent concentration values;
- Observe the instructions provided by the detergent manufacturer.
- Always wear protective safety glasses and gloves.

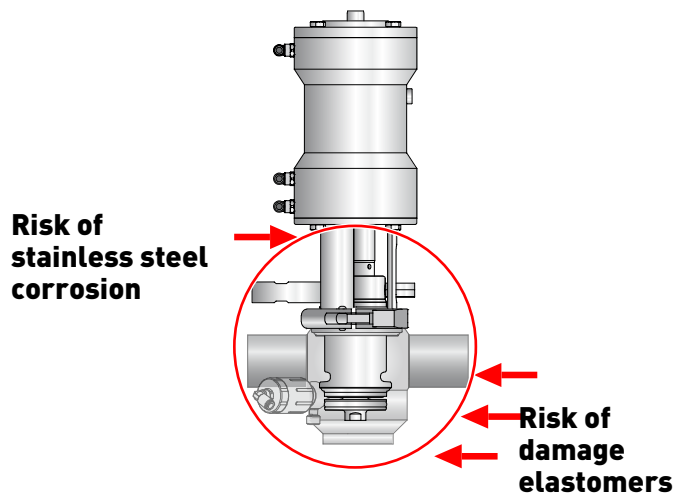

IMPORTANT!

- Accurately dose detergents to avoid excessive concentration;
- Always rinse thoroughly with clean water after washing.
- Check compatibility of valve materials.

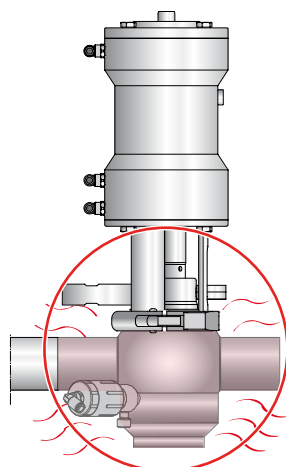

**CAUTION!**

Burns hazard. The valves and piping may be very hot. Wear protective gloves
During the lift and sterilization phases, high temperature liquids may come out of the discharge stub. A suitable exhaust manifold system must be provided.

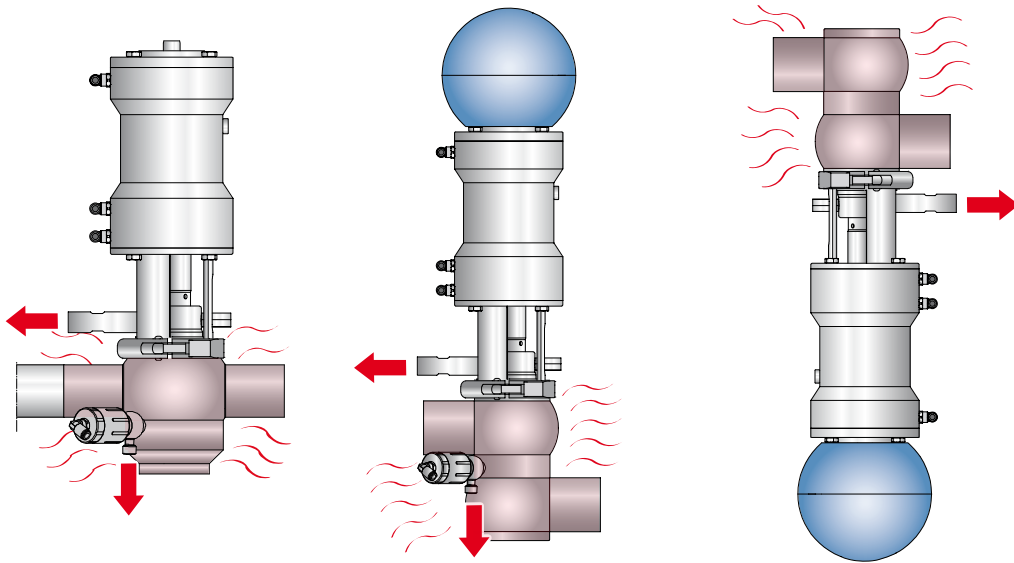
**WARNING**

After installing a new or serviced valve, perform an internal washing cycle before using the piping for food liquids. If there has been any welding work, passivation treatment must be carried out.

EXAMPLE OF INTERNAL WASHING CYCLE (CIP)

Phases	Temperature °C	Washing product
Initial rinse	Environment	Chlorine- and chloride-free water
Washing	70 °C	Caustic soda (NaOH) at 1%
Intermediate rinse	Environment	Chlorine- and chloride-free water
Washing	70 °C	Nitric acid (HNO ₃) at 0.5%
End rinse	Environment	Chlorine- and chloride-free water

Recommended washing product velocity = 2m/s

	EPDM	FKM
Product		
Massima temperatura	95°C	95°C
Minima temperatura	-20 °C	-5 °C

	EPDM	FKM
Steam		
Massima temperatura (continuata)	130°C	120°C
Massima temperatura (per un periodo 15-20 min)	150 °C	140 °C

	EPDM	FKM
Soda caustica		
Soluzione di pulizia diluita	<5%	<5%
Temperatura minima	1 °C	1° C
Temperatura massima	80 °C	80 °C

	EPDM	FKM
Acido (Nitrico / Fosforico / Acido peracetico)		
Soluzione di pulizia diluita	<2%	<2%
Temperatura minima	1 °C	1° C
Temperatura massima	40 °C	65 °C

	EPDM	FKM
Disinfezione		
Disinfettante diluito (a base di acido peracetico)	<0,7%	<0,7%
Temperatura minima	1 °C	1° C
Temperatura massima	30 °C	30 °C

LENGHT OF A SEAT LIFT	RECOMMENDED NUMBER OF SEAT LIFTS PER CIP STEP	PRODUCT
1-2 seconds	1-2	Milk
3-5 seconds	3-5	Yogurt
2-5 seconds	2.5	Beer
5-10 seconds	5-10	Cold wort

9 Disposal



At the end of its service life, the device must be recycled in accordance with the legislation in force in the country of valve use.

Any hazardous residues must be taken into consideration and adequately handled.

The valve is made of AISI 316L and AISI 304 stainless steel, elastomers (gaskets), plastic (control unit) and electrical components (terminal boards, solenoid valves, sensors).

Adhere to the following steps before disconnecting the valve and refer to the heading "General Maintenance".

- make sure the line on which the valve is installed in is not in use
- empty the line on which the valve is installed and clean if necessary
- disconnect the air supply if it is not required during dismantling
- disconnect the valve from the power supply
- remove the valve from the system
- move the valve in observance of the rules set out in the heading "Lifting"
- to dismantle the valve, refer to the heading "Disassembly"

10 Maintenance

10.1 General maintenance



1. MAINTENANCE PRECAUTIONS

Maintenance operations must be carried out by expert technicians only.



CAUTION!

Maintenance operations must be carried out with the line stopped and all utilities (electricity, compressed air) disconnected.

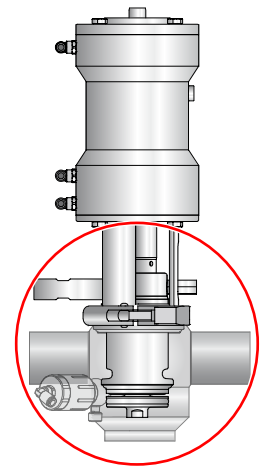

CAUTION!

Always discharge the fluid pressure in the valve and piping before disassembling the valve.



CAUTION!

Burns hazard. The valves and piping may be very hot. Wear protective gloves

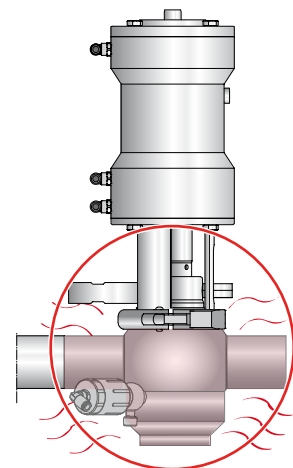



2. CLEANING AWAY DEPOSITS:

- Thoroughly wash and clean all the valve parts before disassembly;
- Pay attention to any possible detergent or other aggressive fluid deposits (see "Cleaning");
- Always use protective safety glasses and gloves when required.

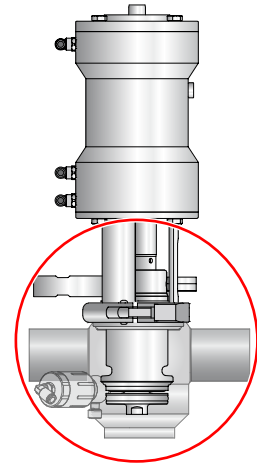

CAUTION!

Hand crushing hazard. During operation there is a crushing hazard caused by the discharge stub pipe. Never put hands in the valve openings.



3. REPLACEMENT OF WORN VALVE PARTS:

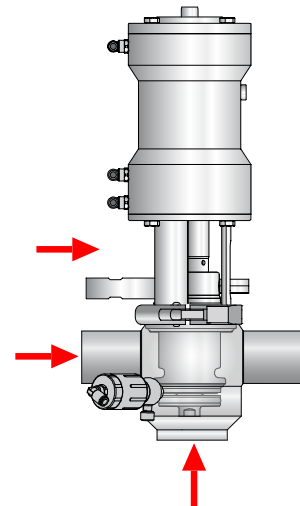

Always use original spare Parts



10.2 Scheduled maintenance

SCHEDULED MAINTENANCE	VALVE GASKETS	ACTUATOR GASKETS
Preventive	Replace after 12 months	Replace after 24 months
In the event of leaks	Replace at the end of the day	Replace in the event of leaks
Periodical	Check correct operation and that there are no leaks	Check correct operation and that there are no leaks
	Record the actions carried out	Record the actions carried out

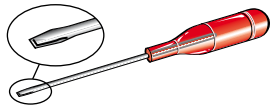
10.3 Tools useful for Disassembly/Reassembly

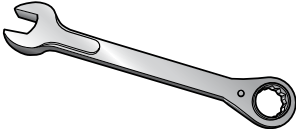
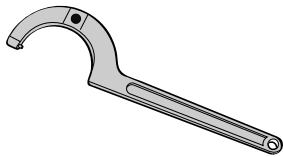
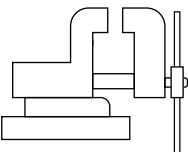
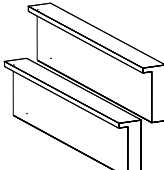
TOOLS	DN25	DN32	DN40	DN50	DN65	DN80	DN100	DN125	DN150
	✓								
	2.5 - 4 - 5 - 6 - 8								
	13							13-17	
	99ST 15-35				99ST 35-50			99ST 50-80	
	✓								
	✓								

10.4 Mixproof valve B93J - B93JPG

NO.	DESCRIPTION	NO.	DESCRIPTION
1	Lower body	85	Secondary spring
2	Upper shutter	90	Sealing ring
4	Sealing ring	91	Sealing ring
9	Cylinder	94	Sealing ring
11	Pin	101	Screw
12	Sealing ring	106	Bush
13	Central piston	120	Sealing ring
14	Sealing ring	121	Sealing ring
16	Sealing ring	154	Thickness
17	Bush	193	Bush
18	Buffer	240	Sealing ring
19	Sealing ring	245	Guide pin
24	Air connector	246	Piston
31	Spring	247	Sealing ring
33	Clamp	248	Cylinder
34	Screw	249	Sealing ring
35	Assembly	251	Air connector
40	Cap	252	Spring
50	Gasket holder disc	265	Cup
51	Lower shutter	266	Sealing ring
52	Cap	267	Sealing ring
53	Lower piston	268	Connector
58	Drive sleeve	269	Sealing ring
60	Sealing ring	270	Sealing ring
61	Sealing ring	271	Discharge stub pipe
62	Sealing ring	284	Screw
66	Upper piston	285	Pin protection
70	Sealing ring		
74	Air connector		
75	Air connector		
77	Nut		
81	Sealing ring		
82	Sealing ring		
83	Sealing ring		

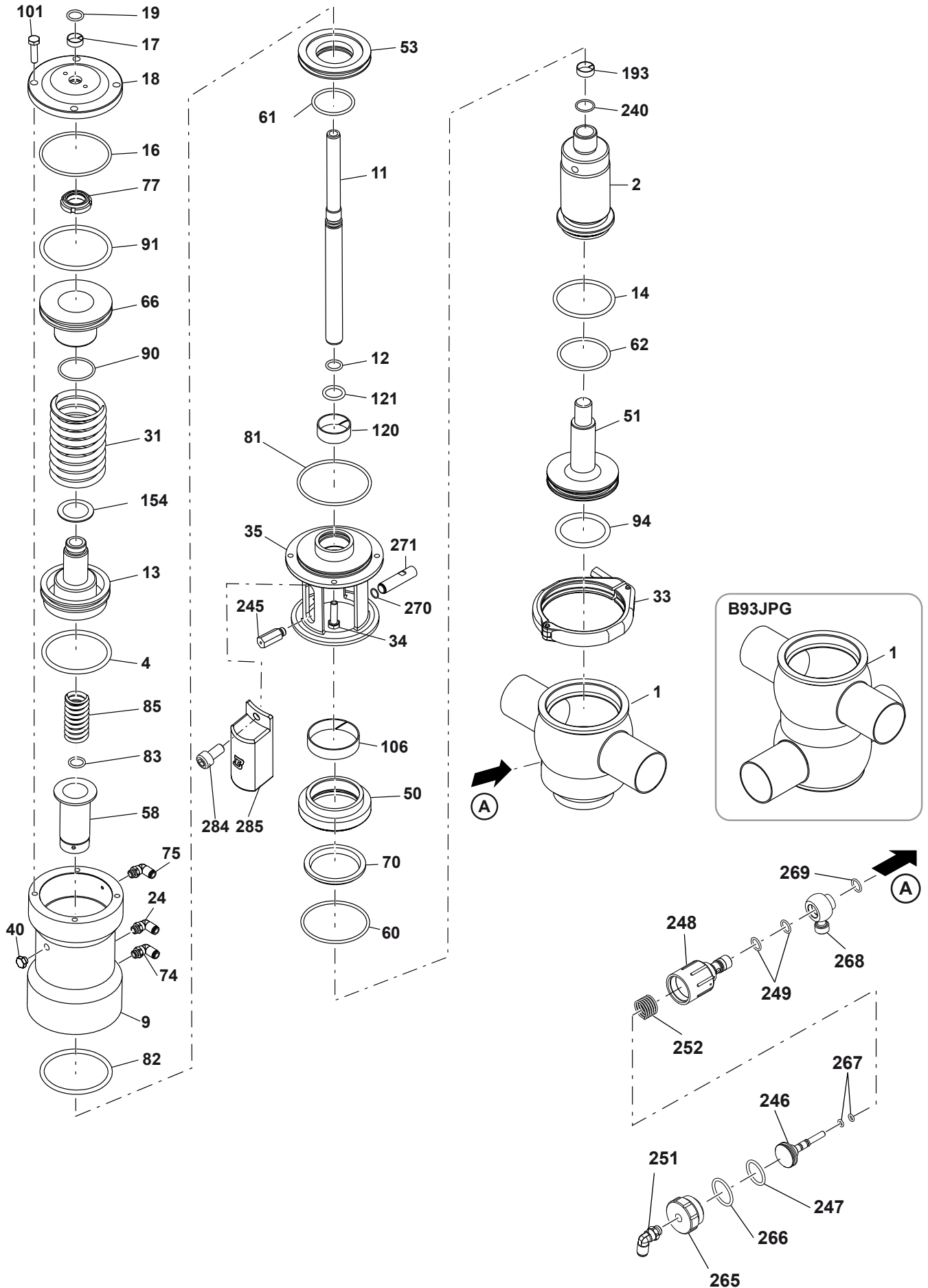

10.5 Disassembly of the B93J - B93JPG

1

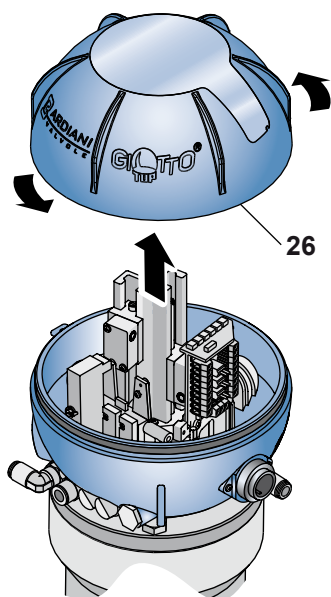

2

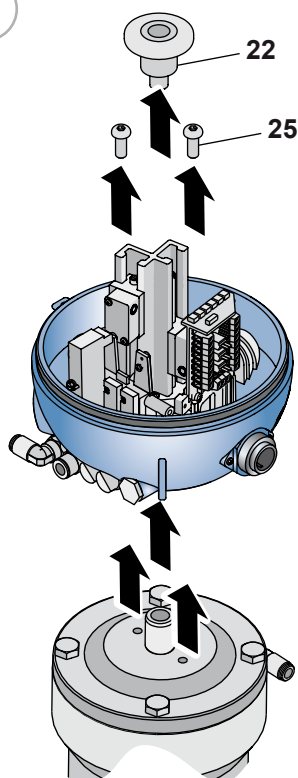

3

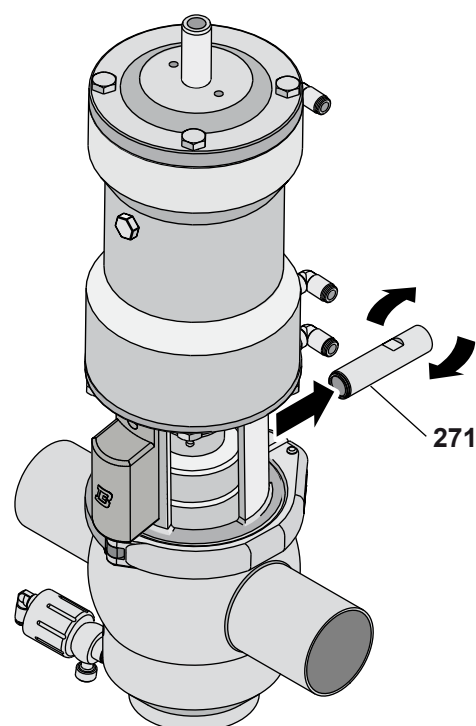

4

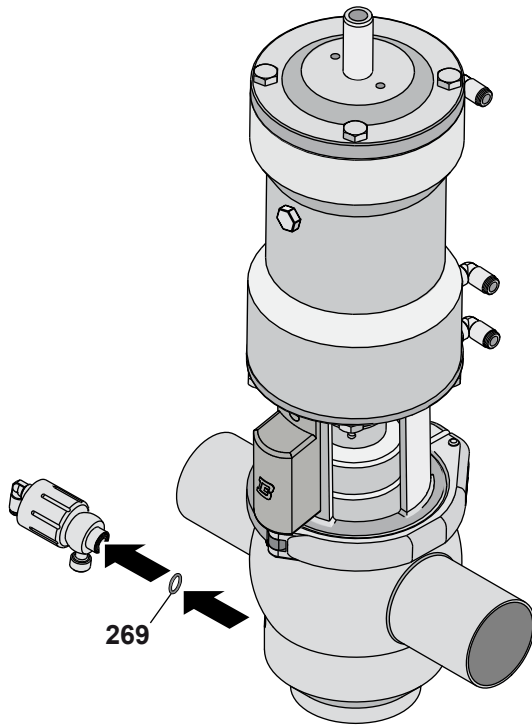

5

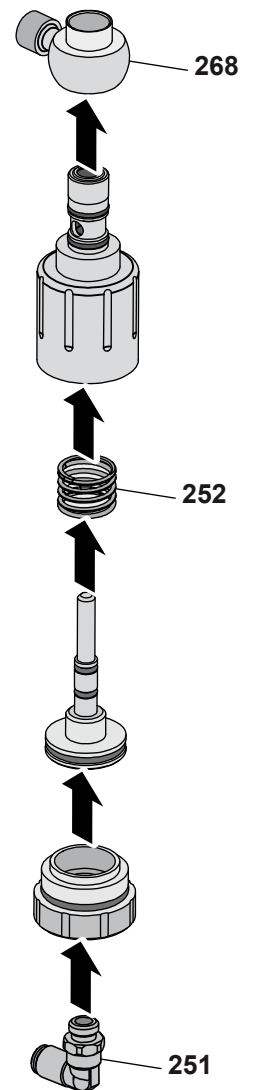

6

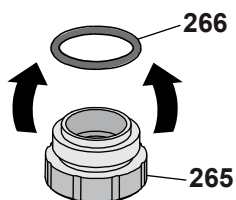

7

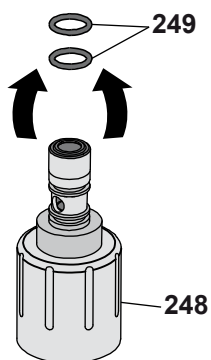

8

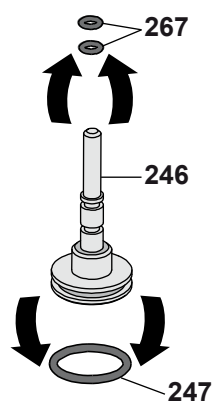

9

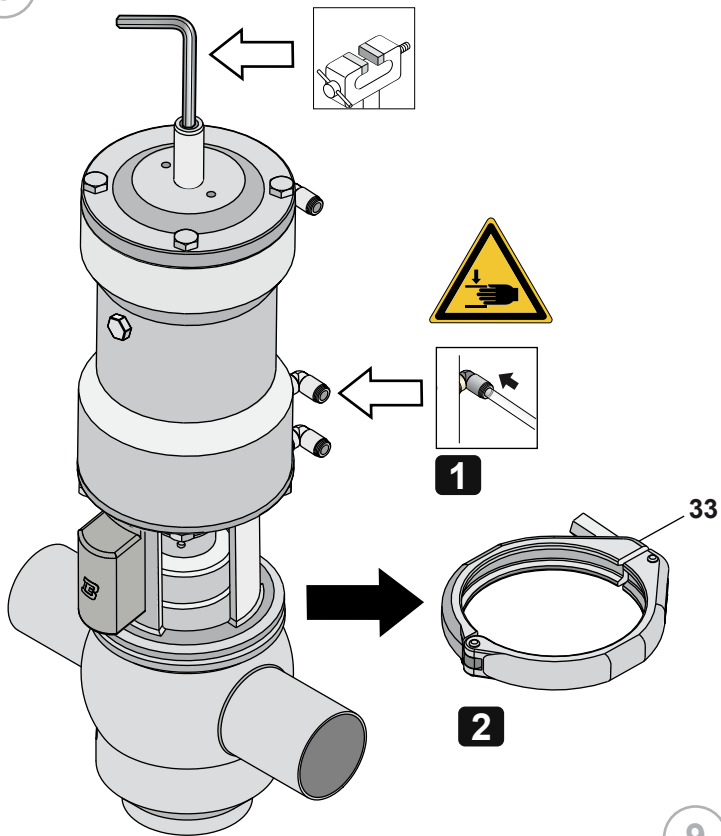

9-b

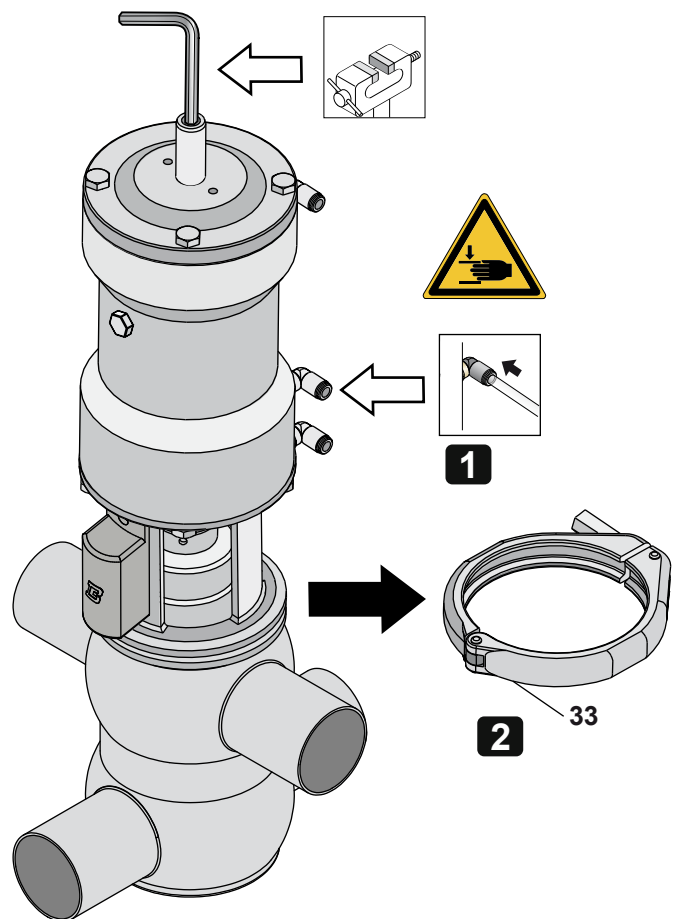

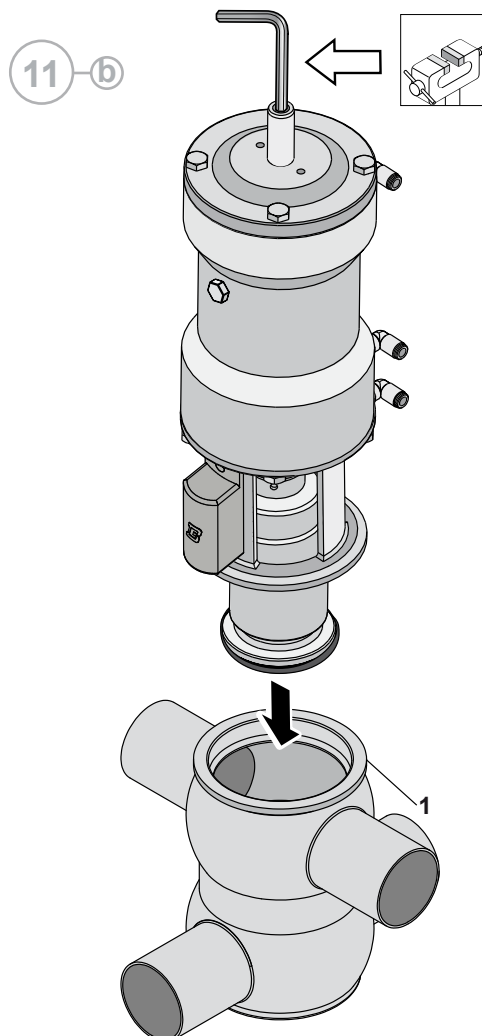
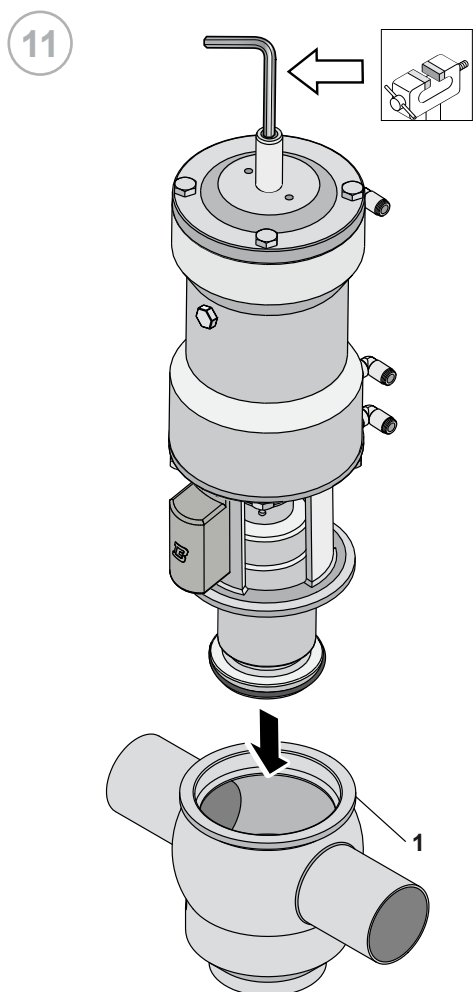
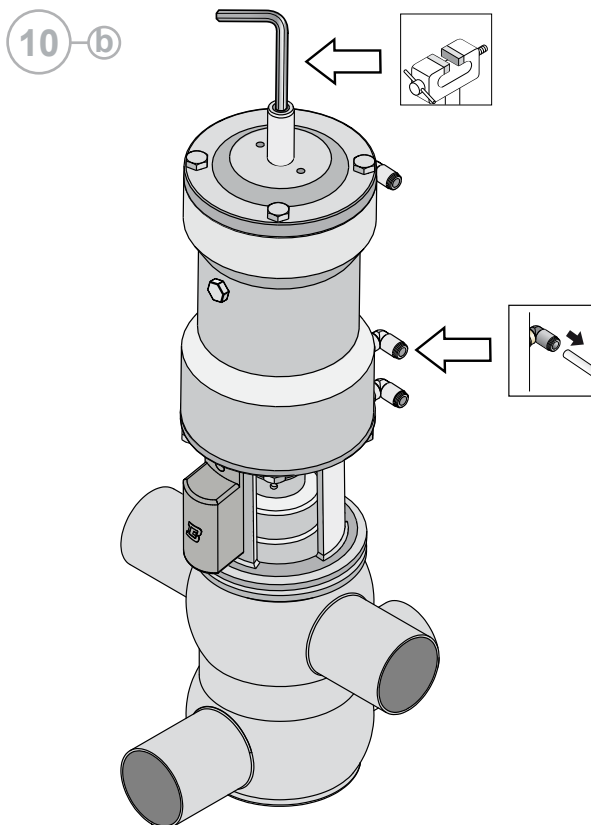
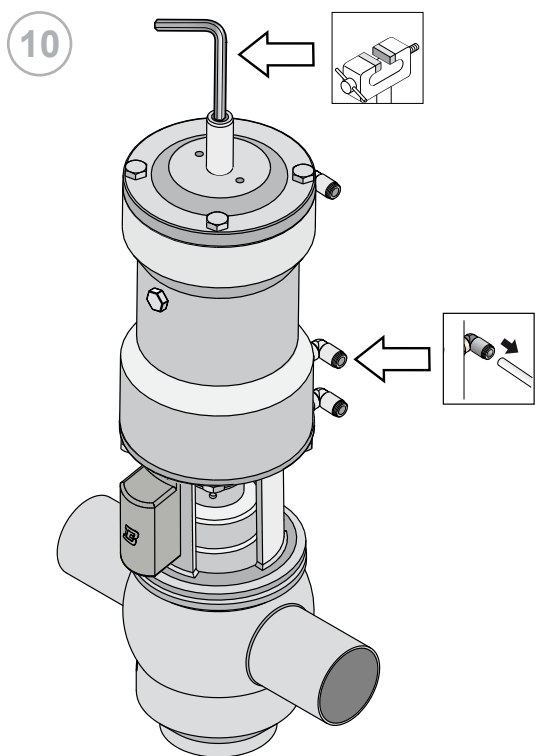

12

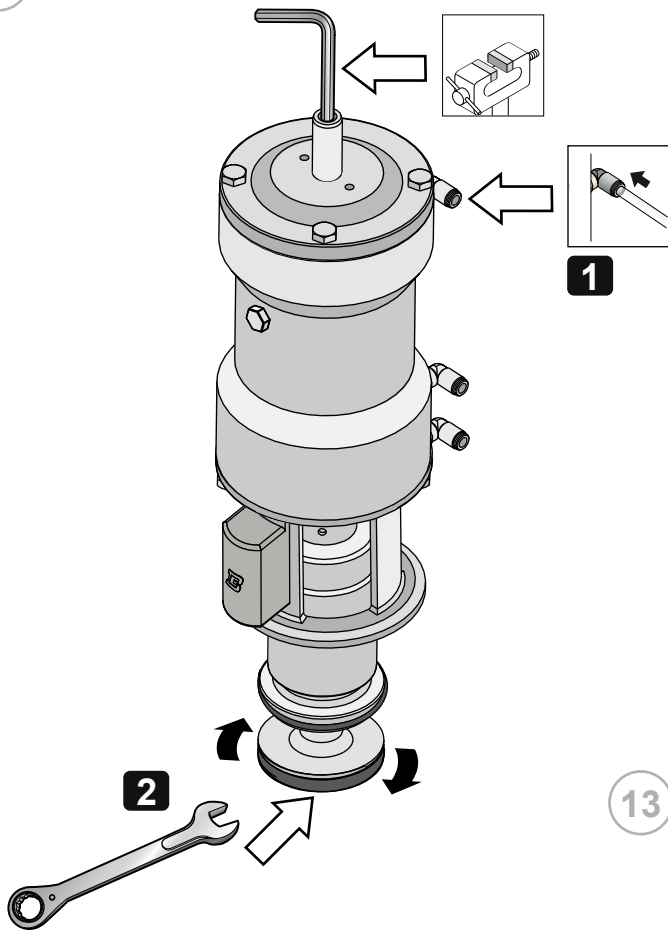

Never touch the moving parts if the actuator is supplied with compressed air

13

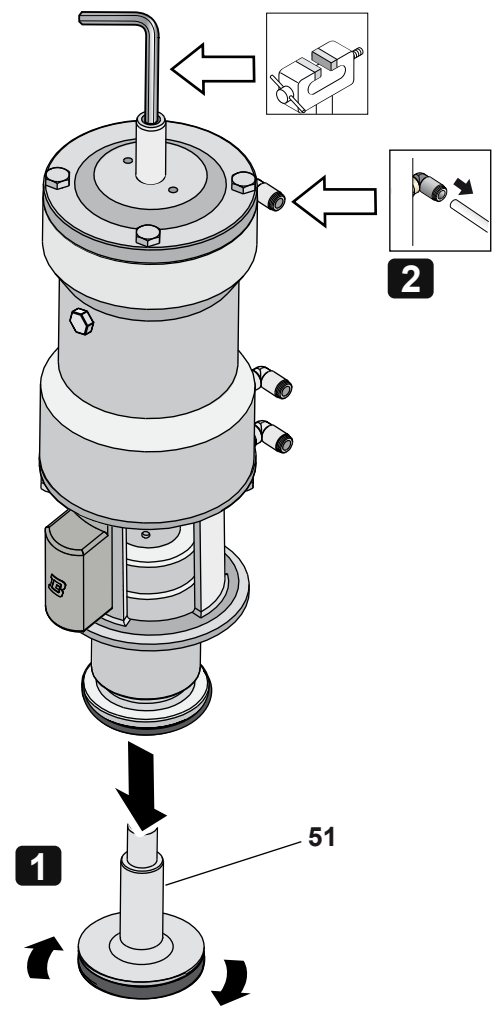

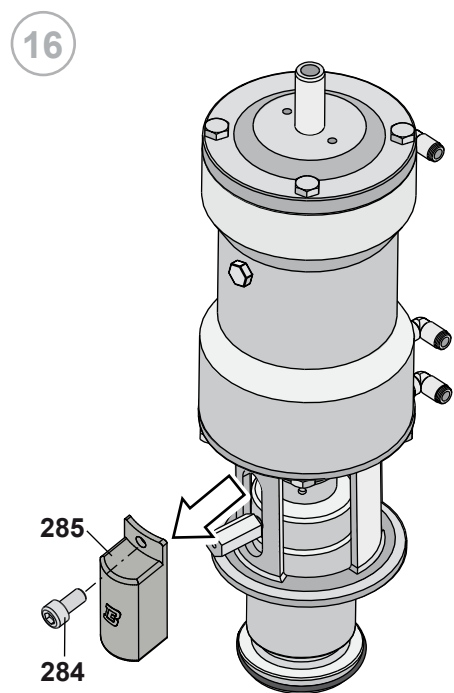
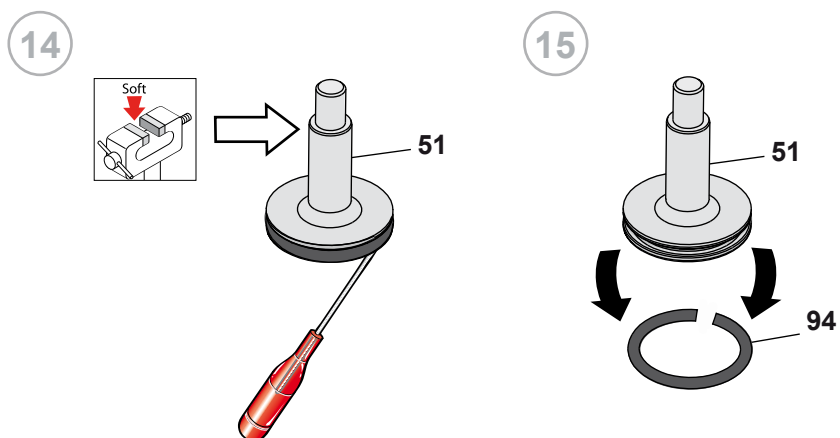

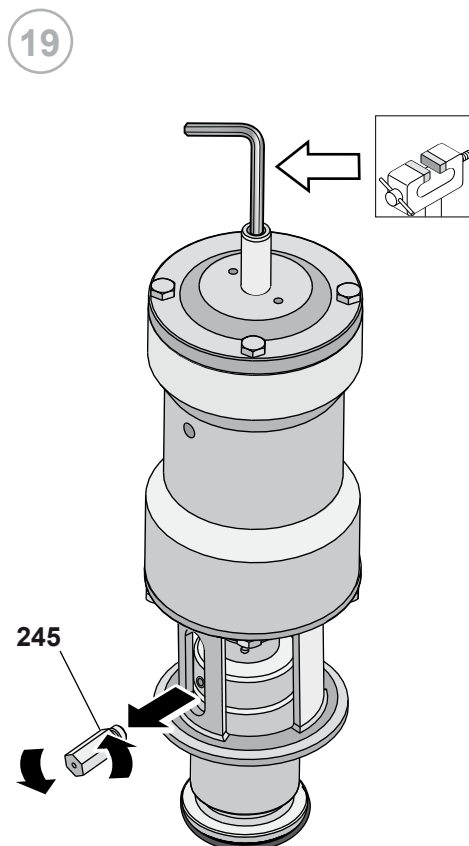
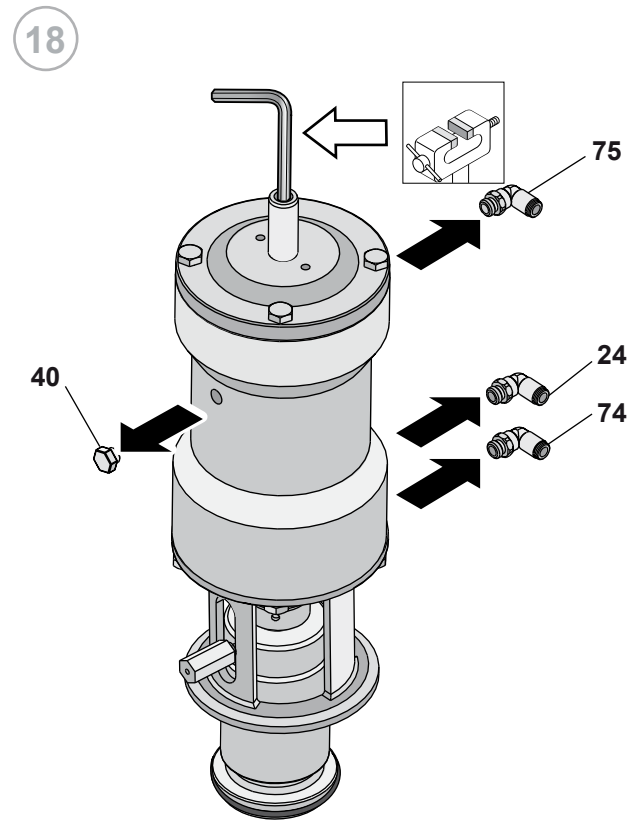
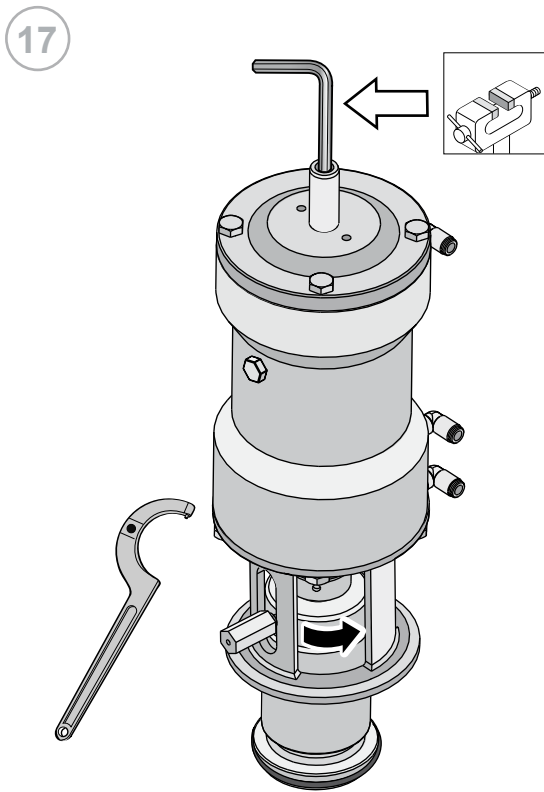

20

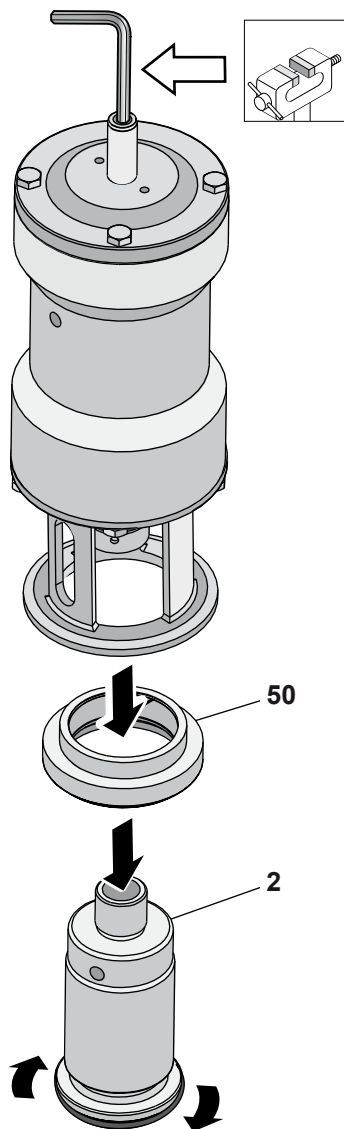

21

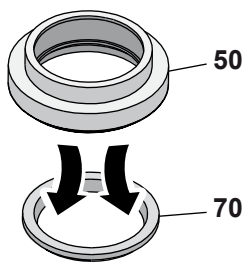

22

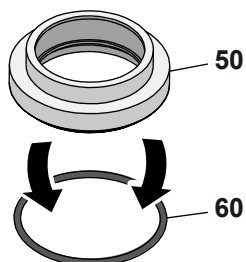

23

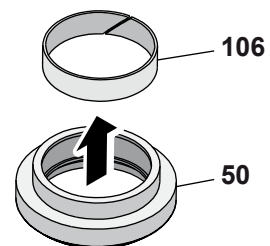

24

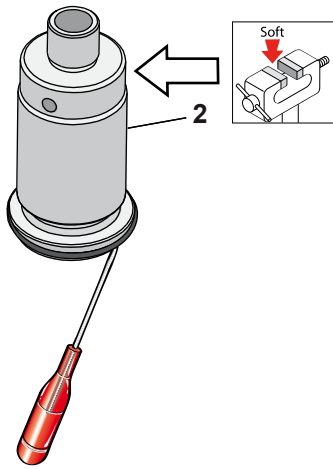

25

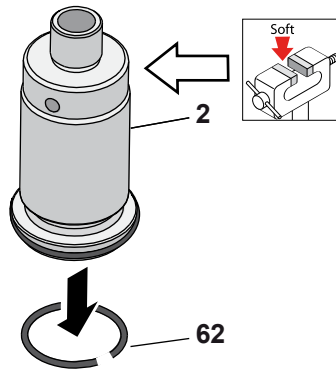

26

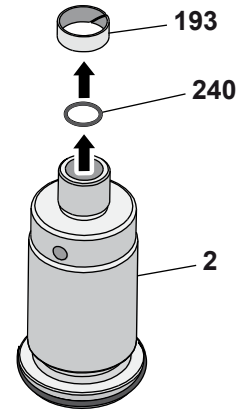

27

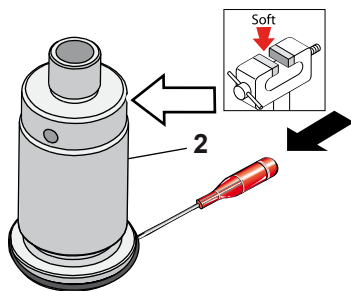

28

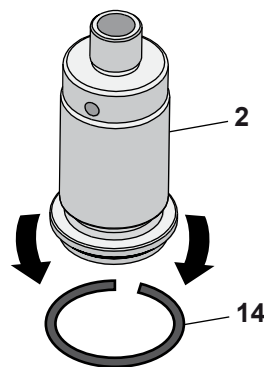

29

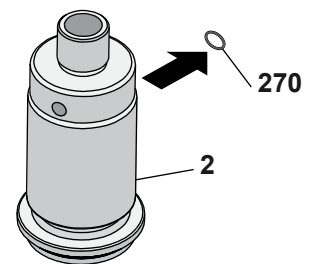

30

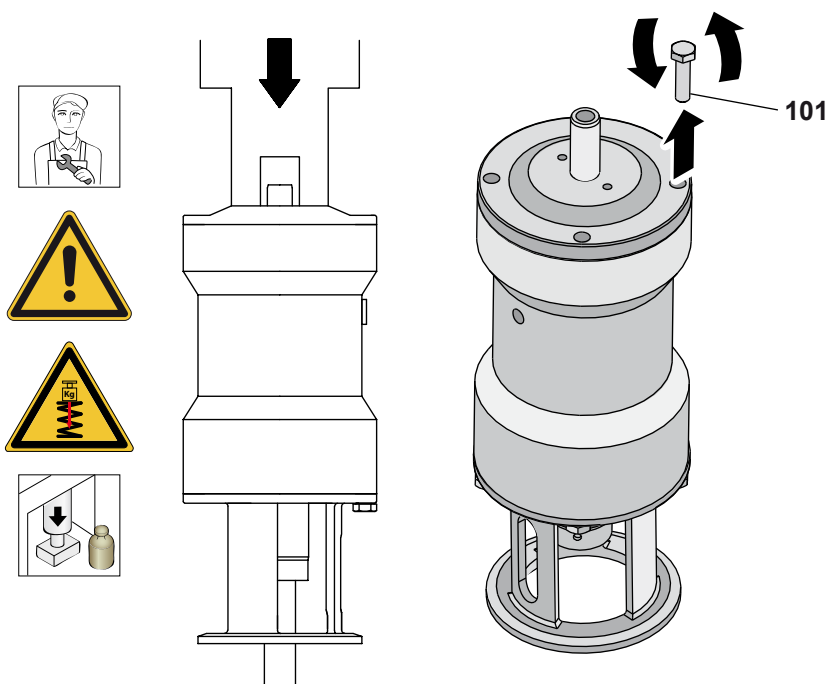

31

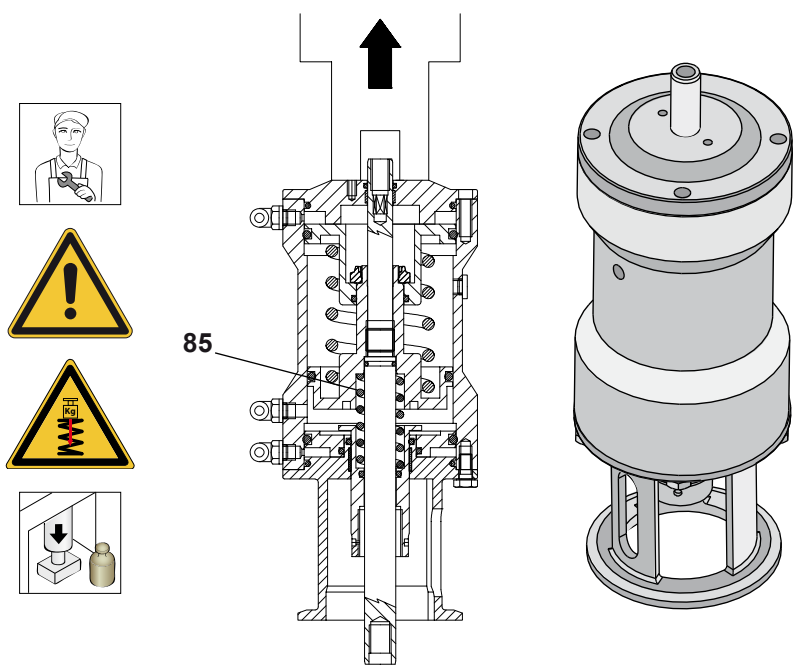

32

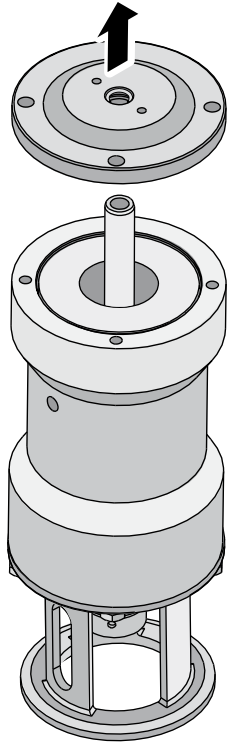

33

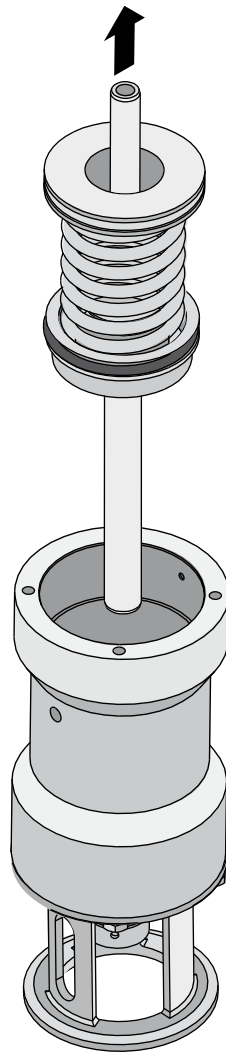

34

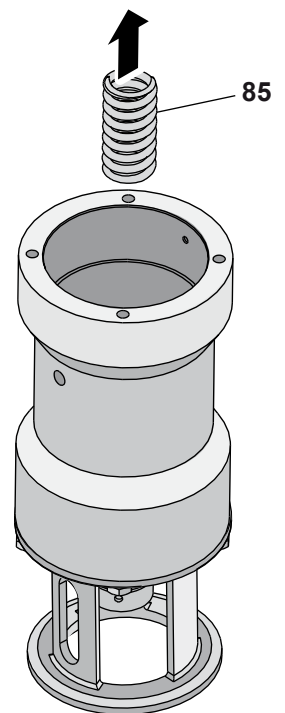

35

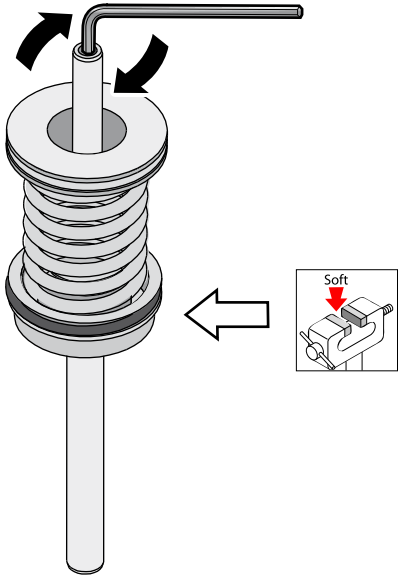

36

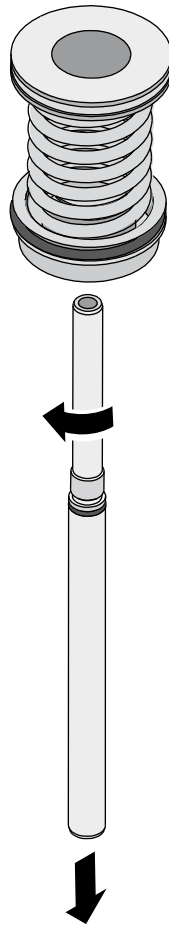

37

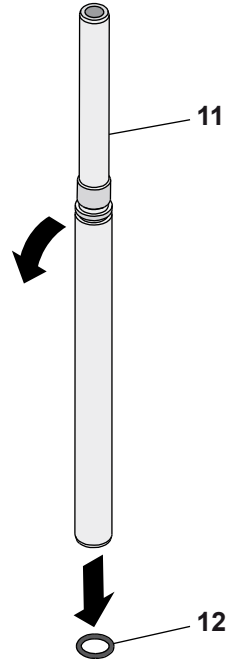

38

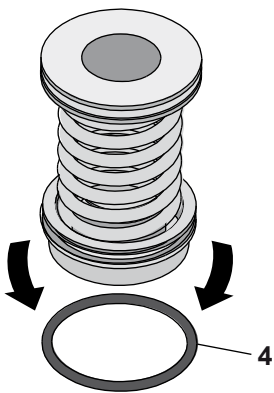

39

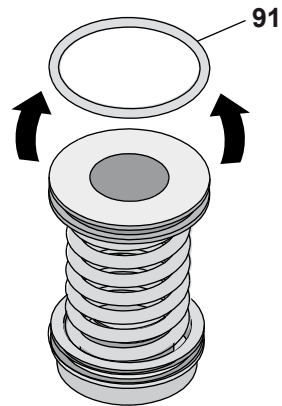

40

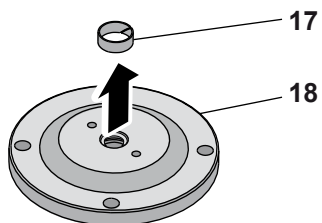

41

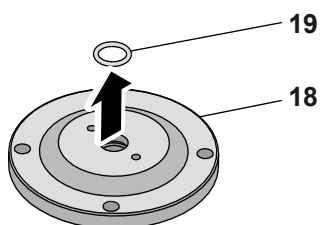

42

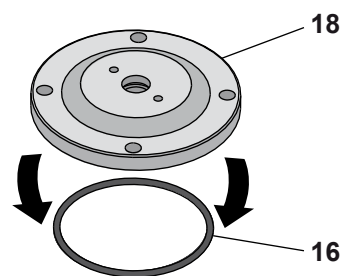

43

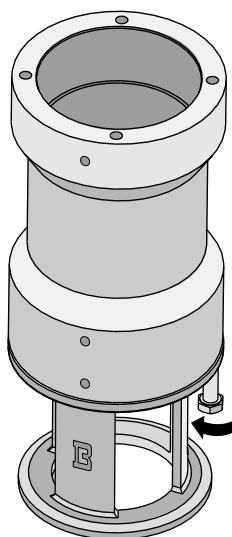

44

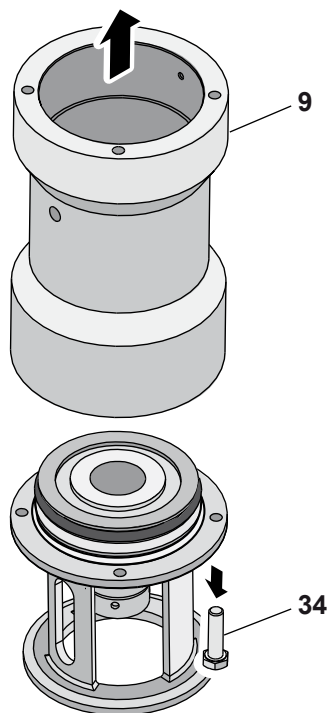

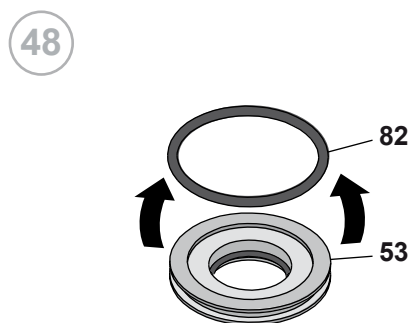
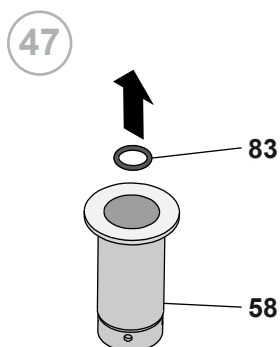
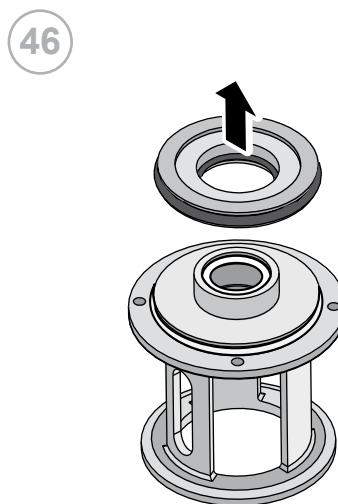
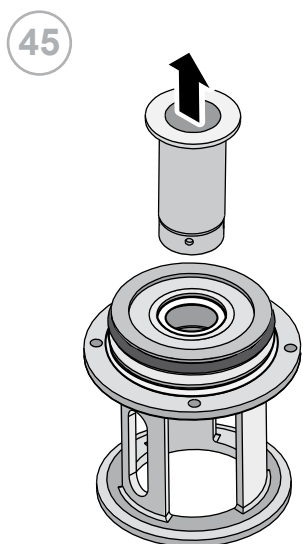

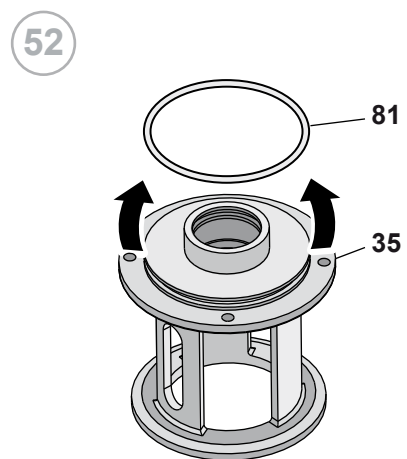
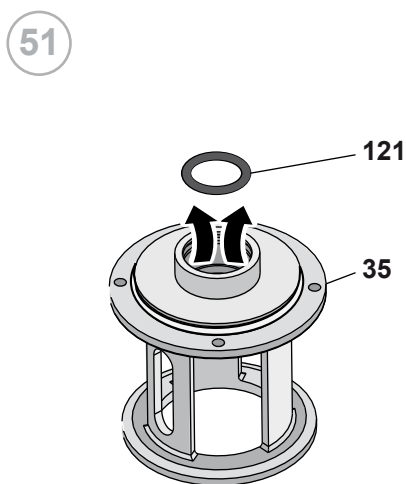
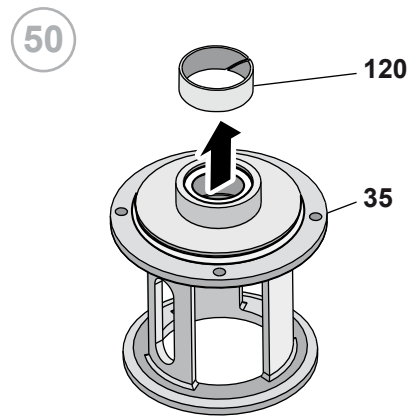
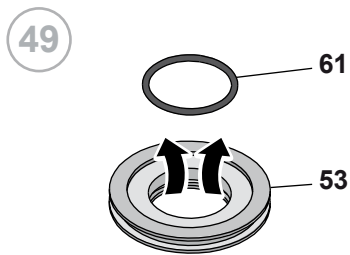

10.6 Assembly of the B93J - B93JPG

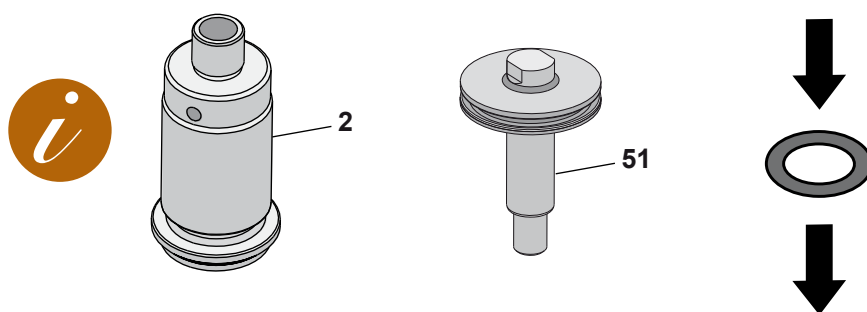
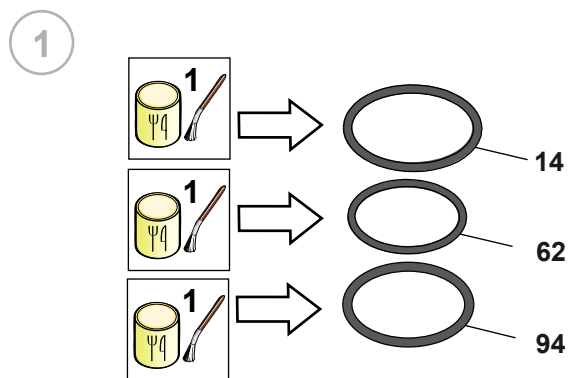

a

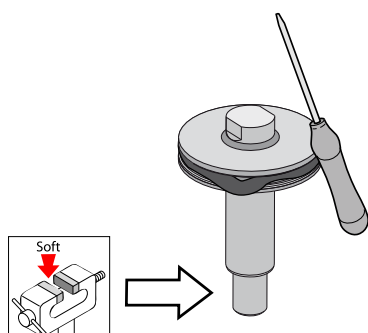

b

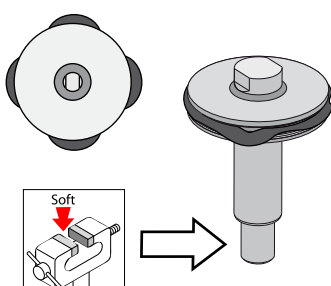

c

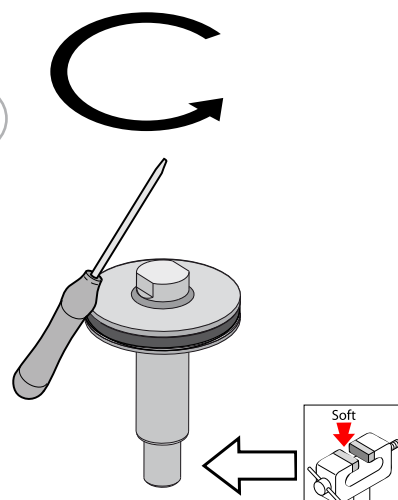

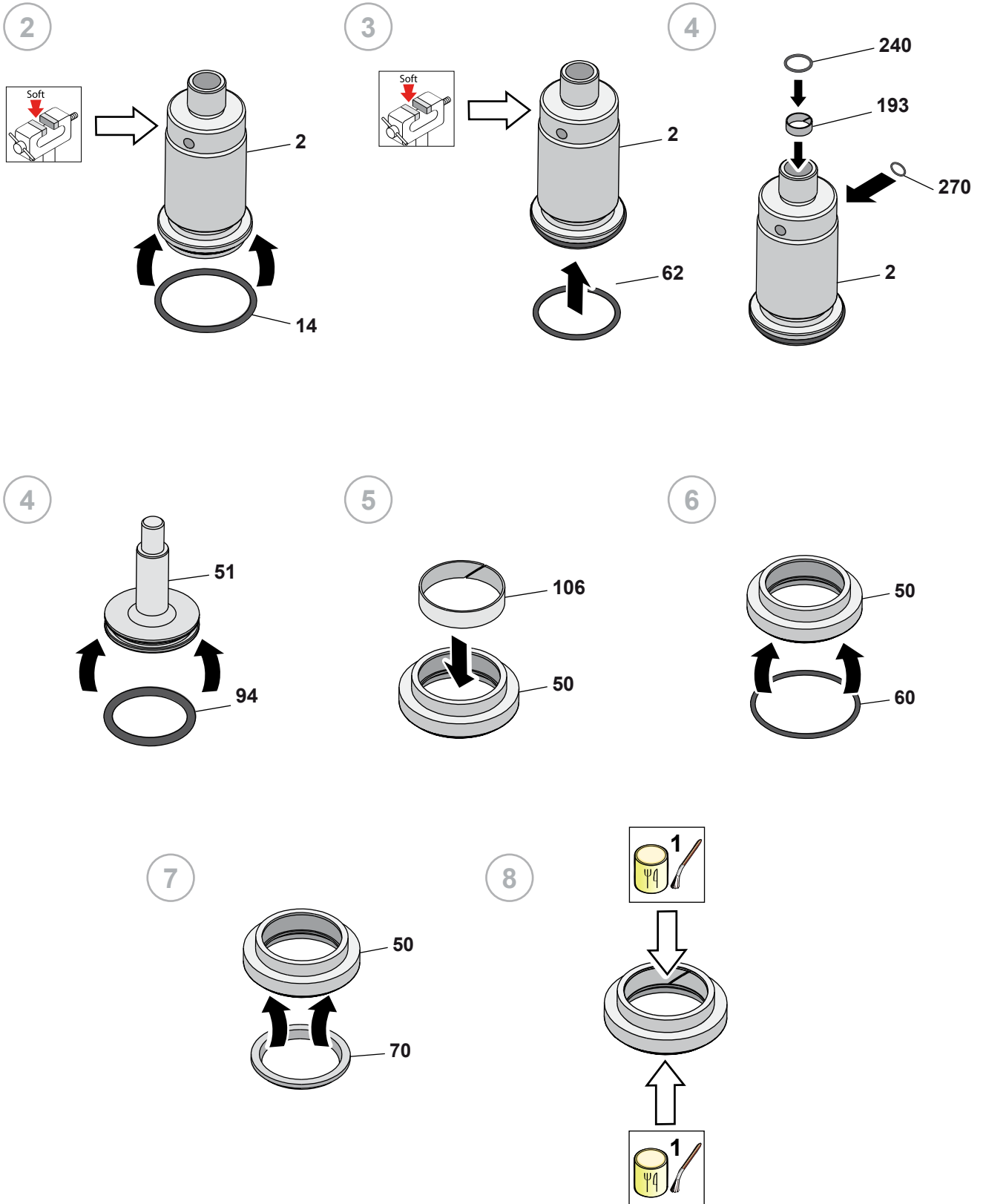

9

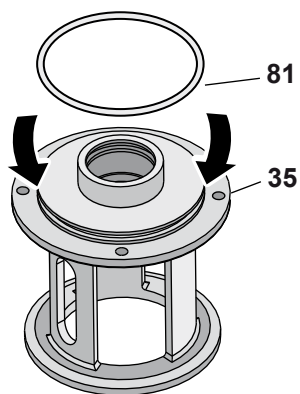

10

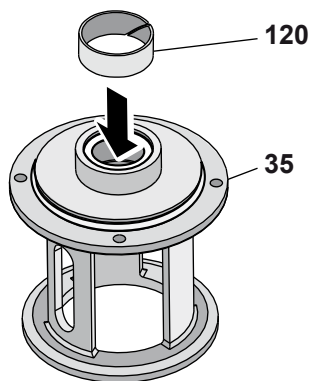

11

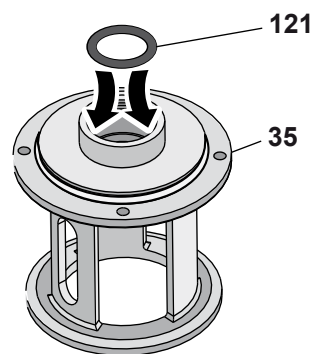

12

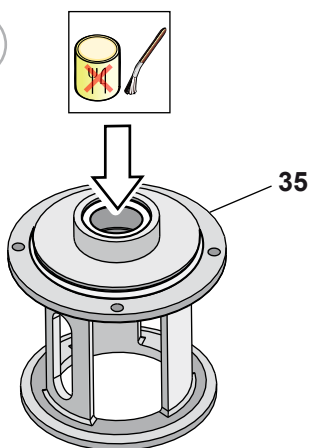

13

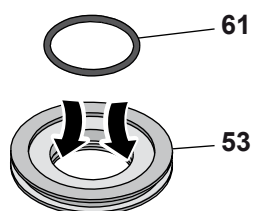

14

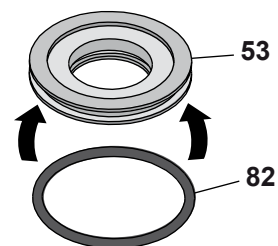

15

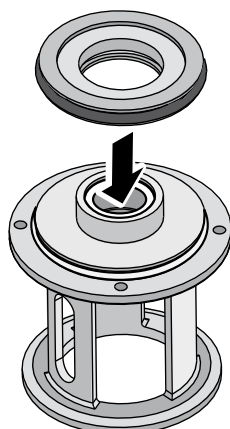

16

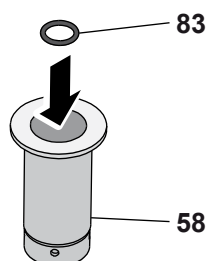

17

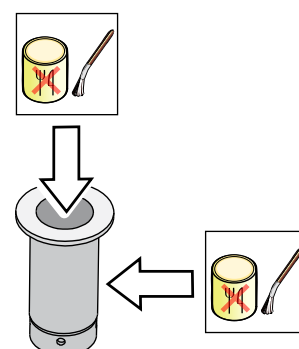

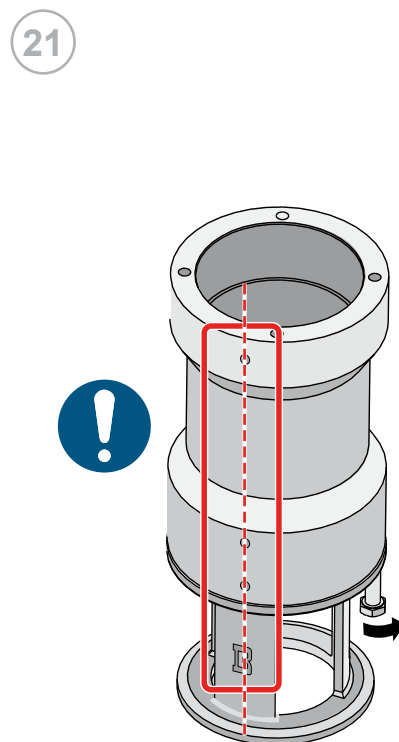
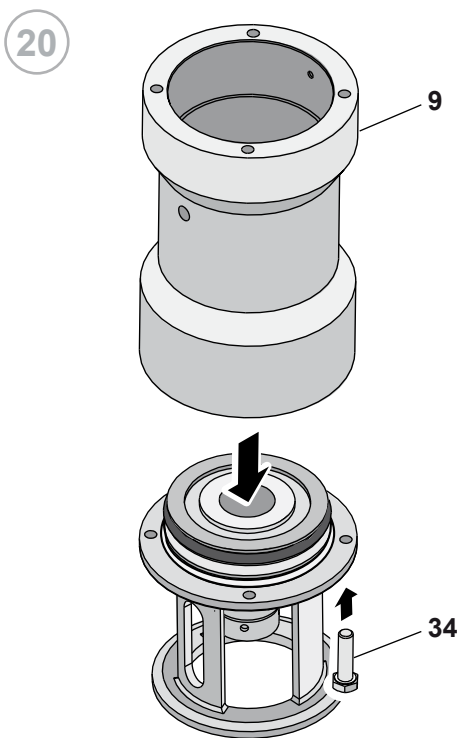
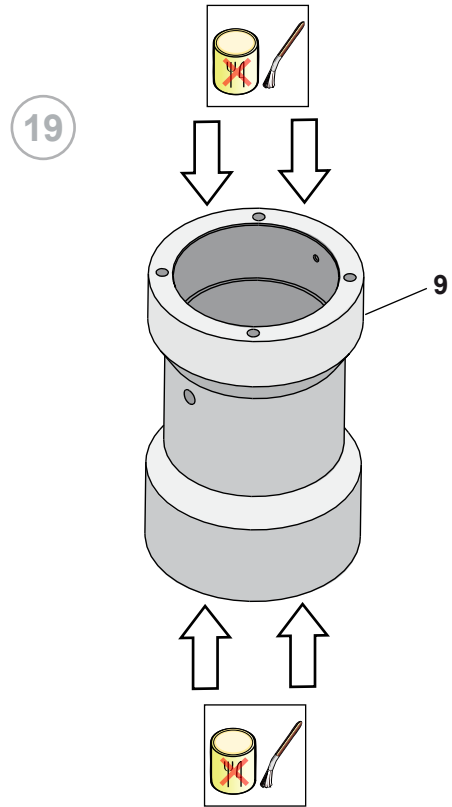
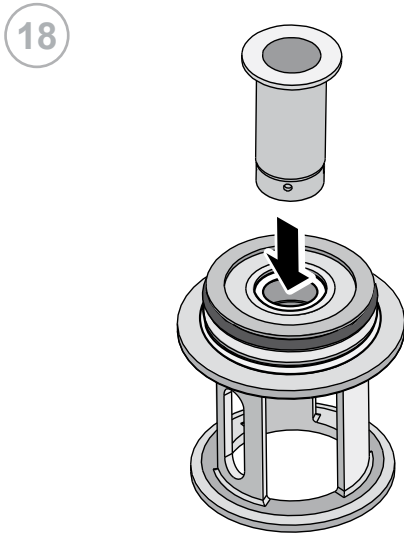

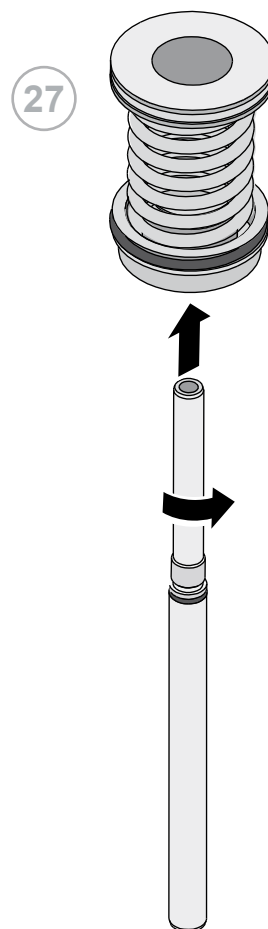
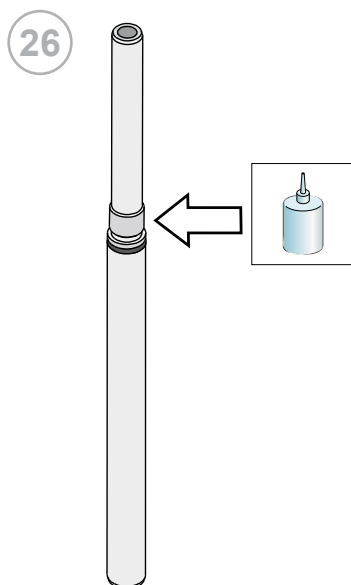
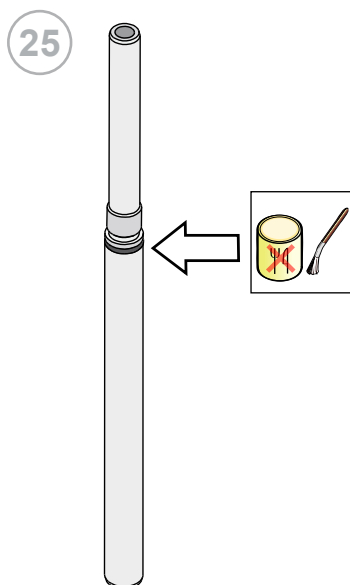
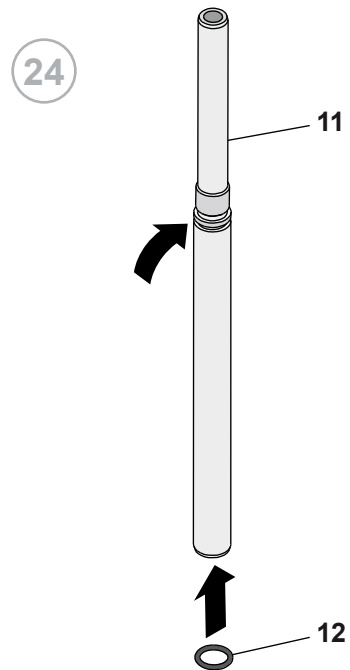
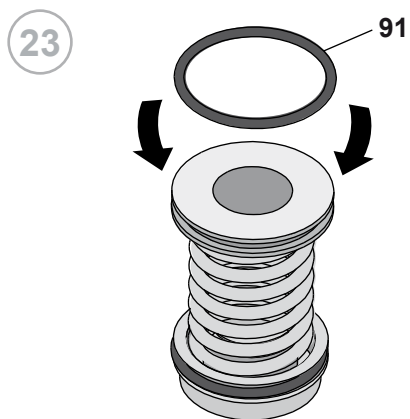
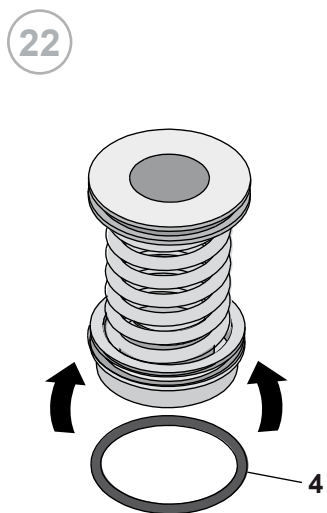

28

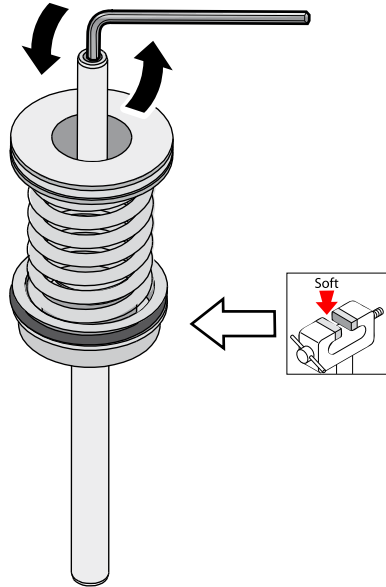

29

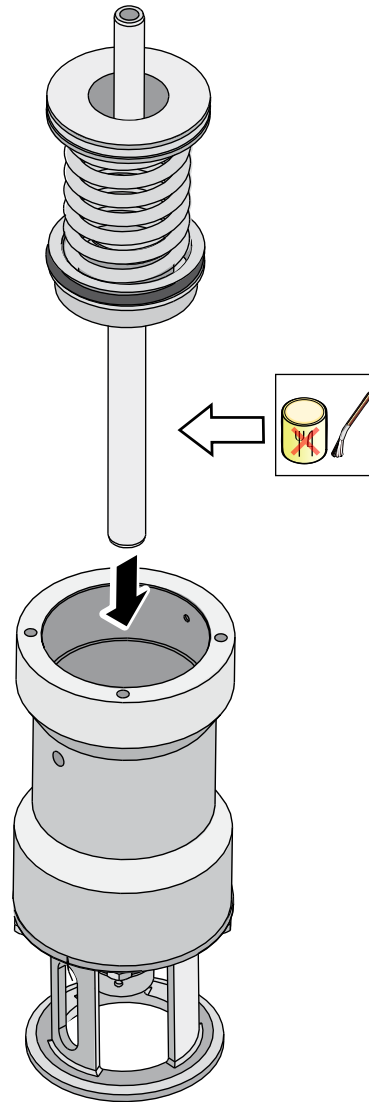

30

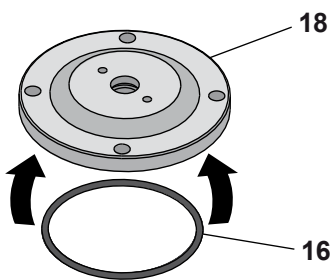

31

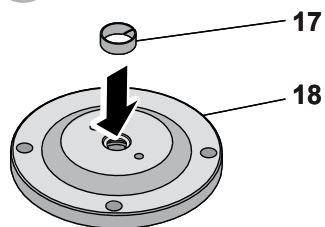

32

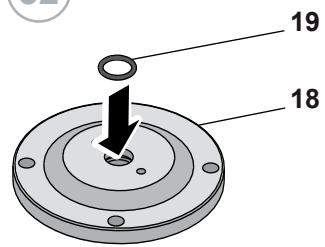

33

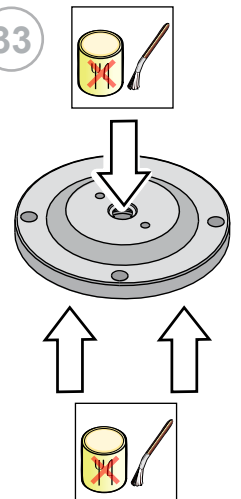

34

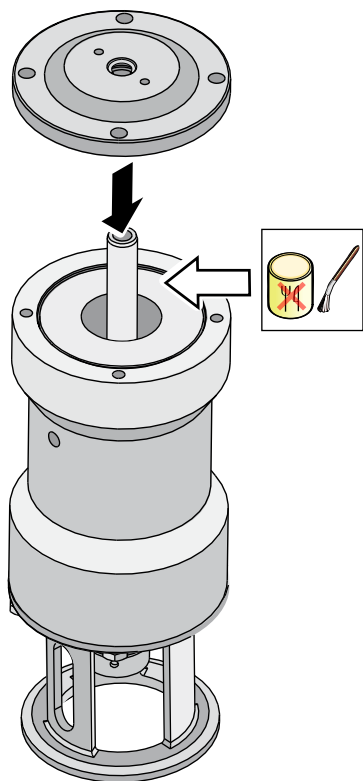

35

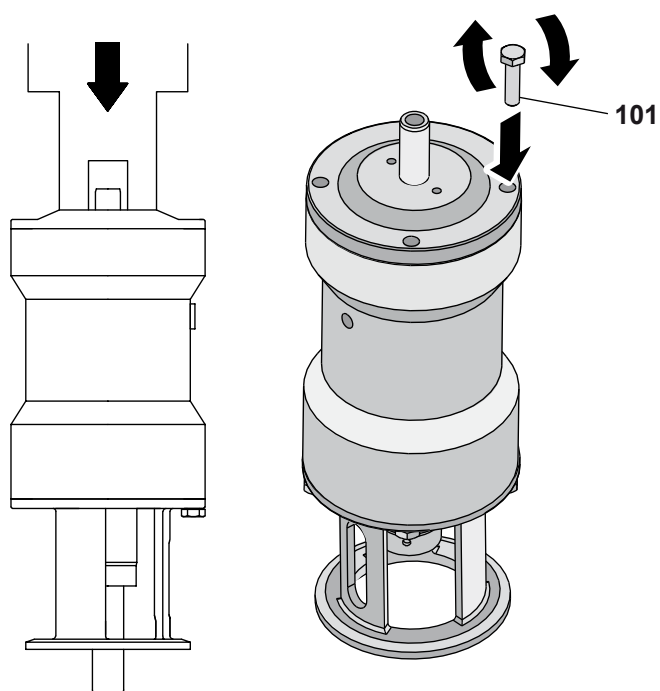

36

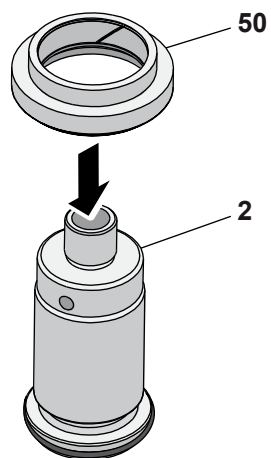

37

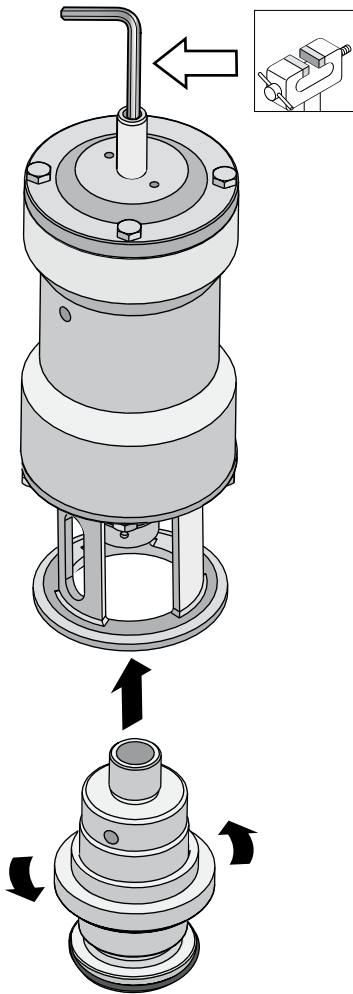

38

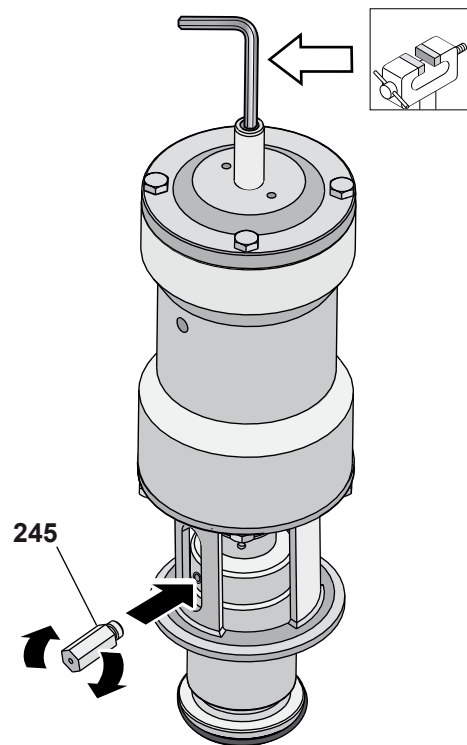

39

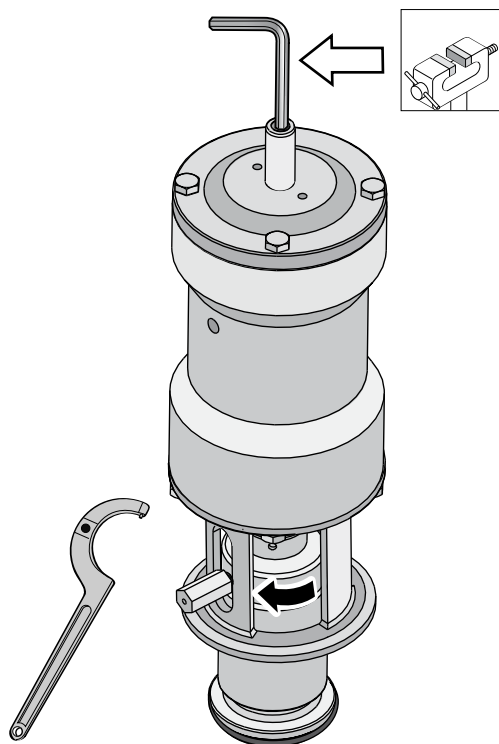

40

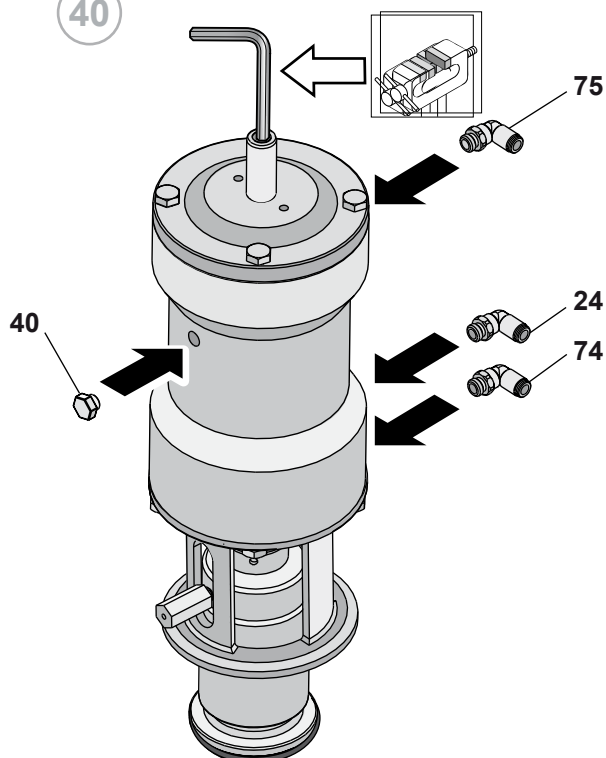

41

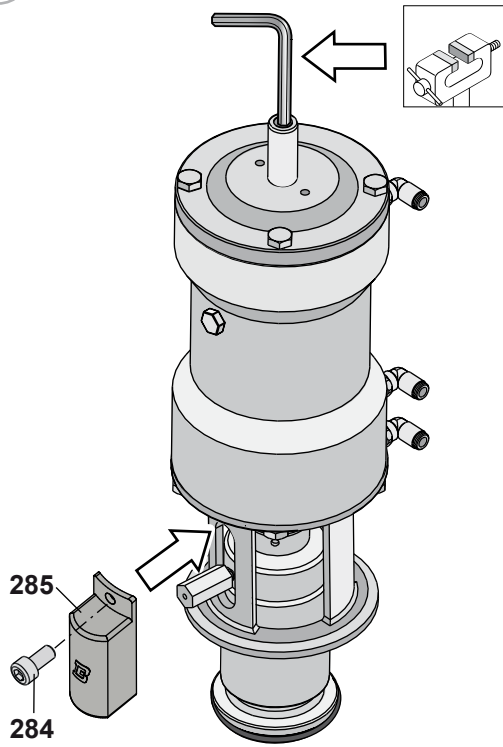

42

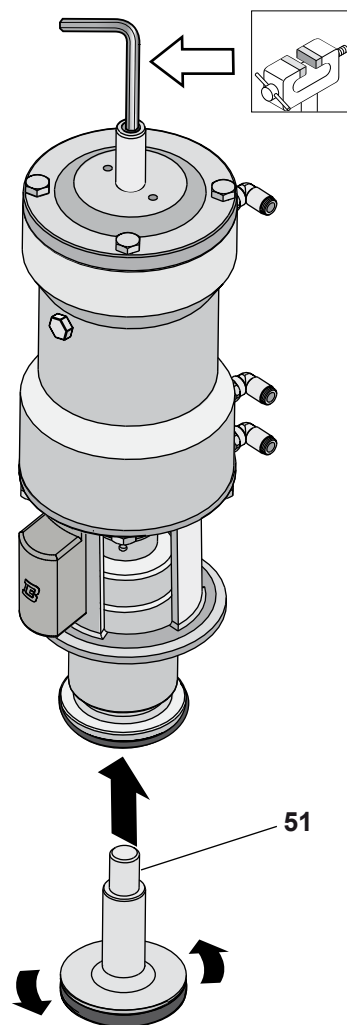

43

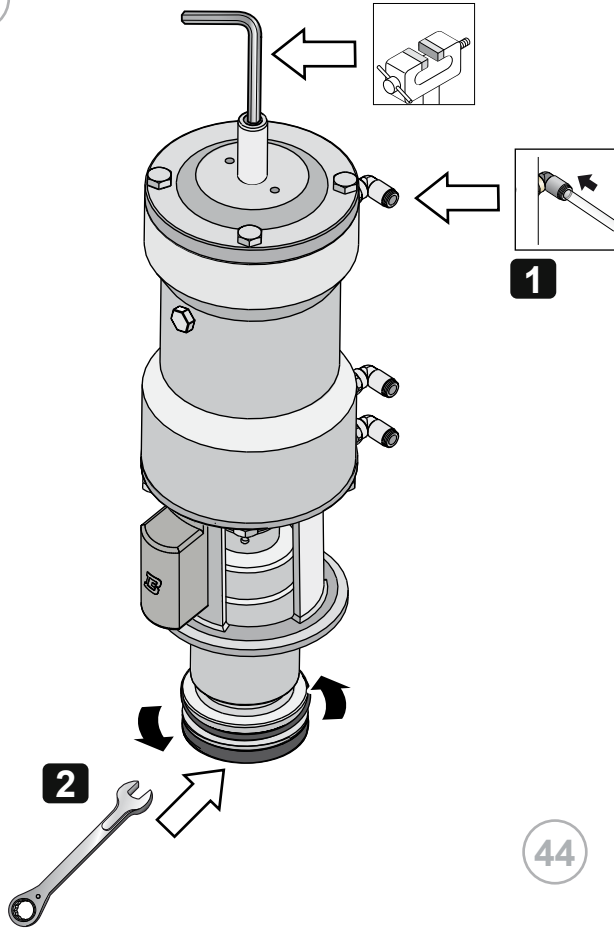

Never touch the moving parts if the actuator is supplied with compressed air

44

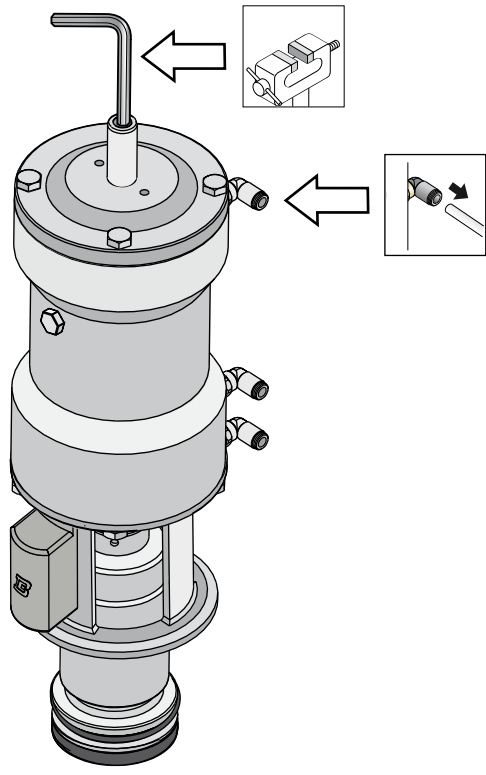

45

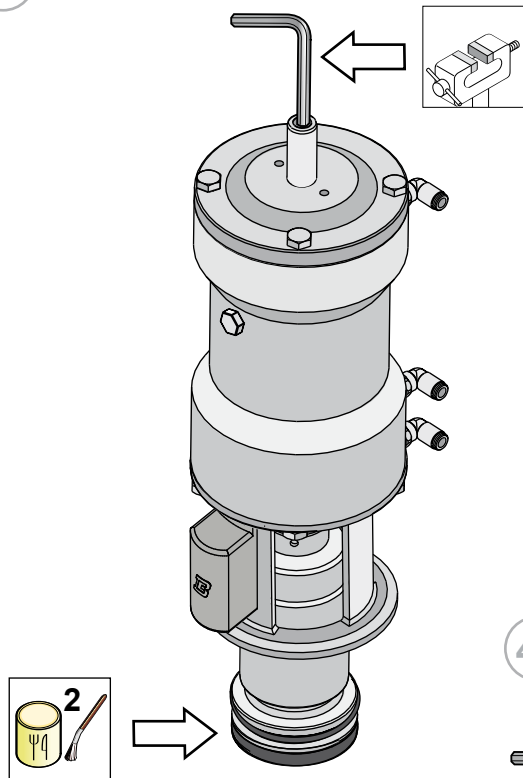

46 a

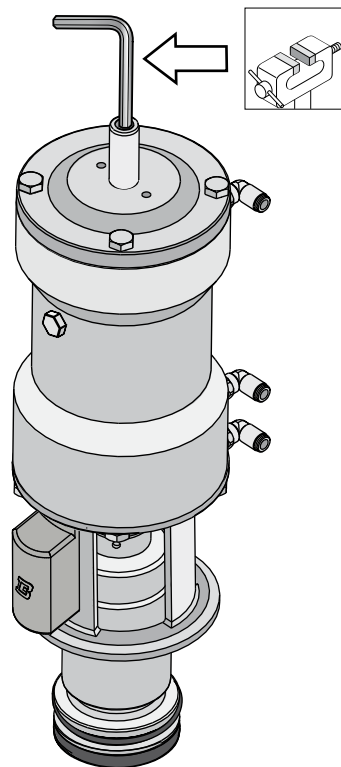

46 b

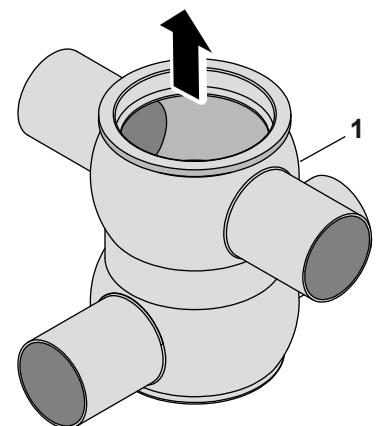
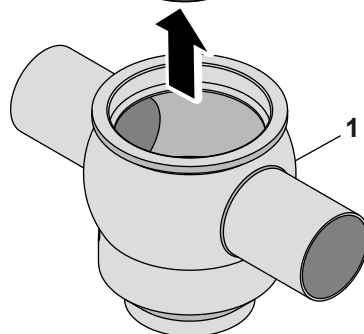
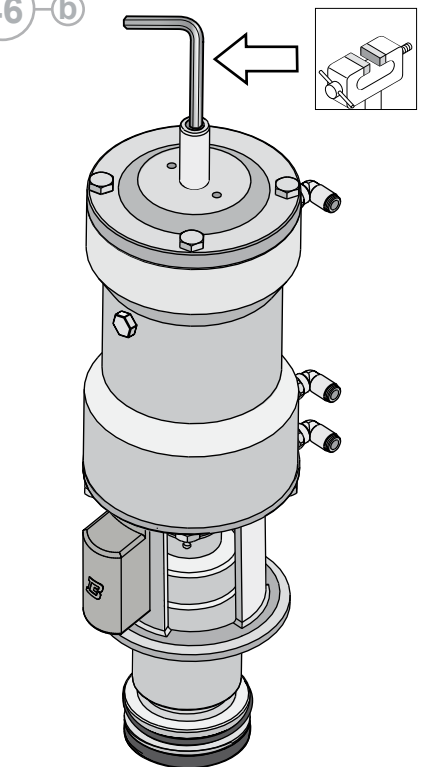

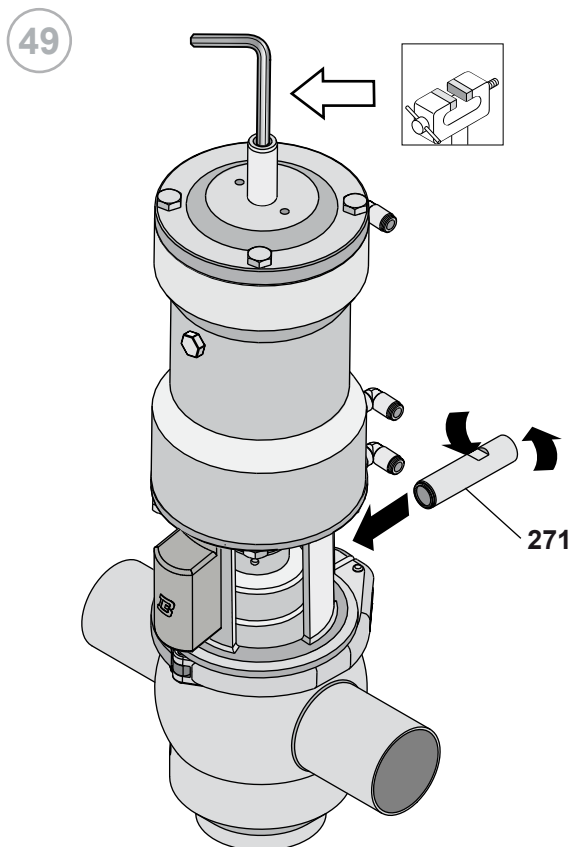
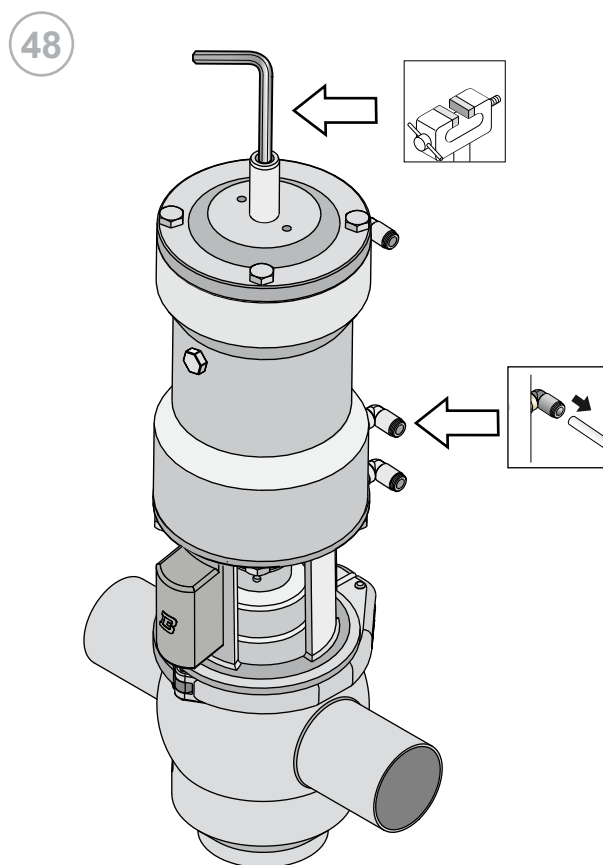
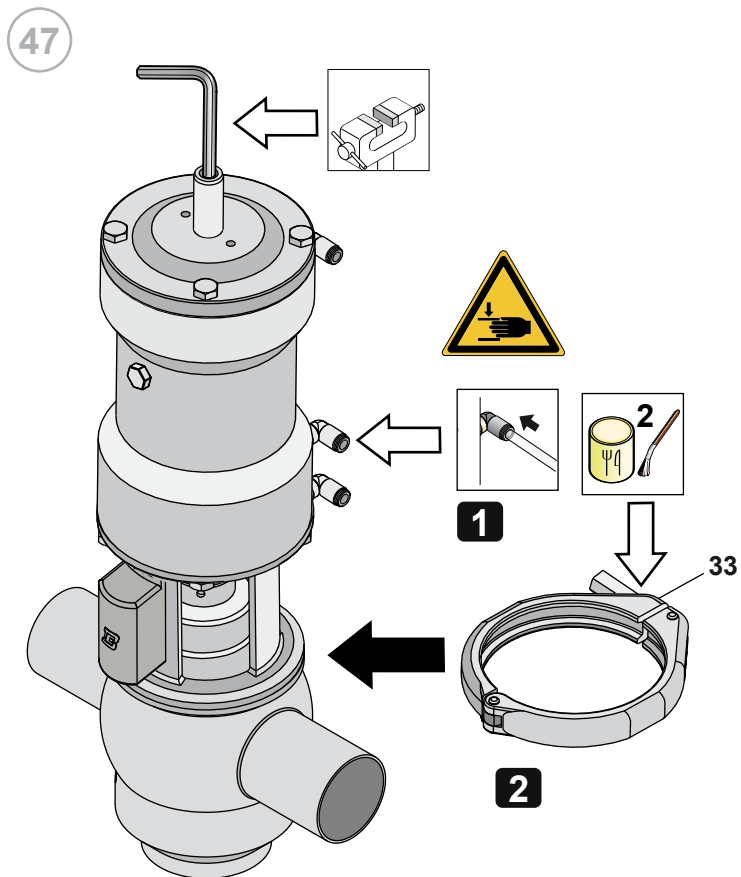

50

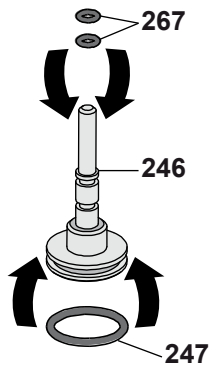

51

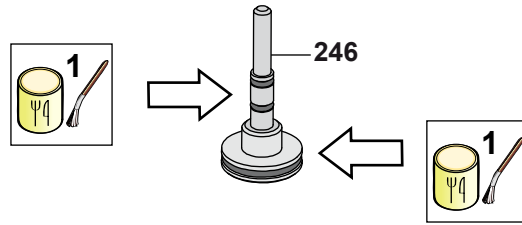

52

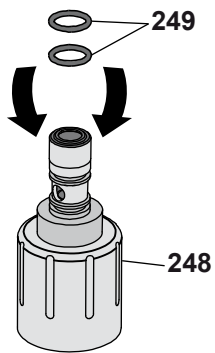

53

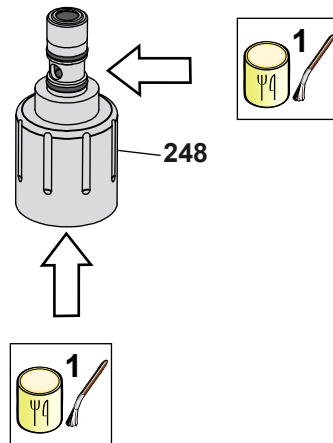

54

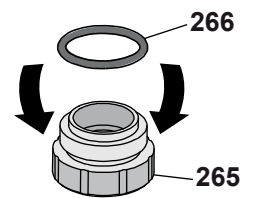

55

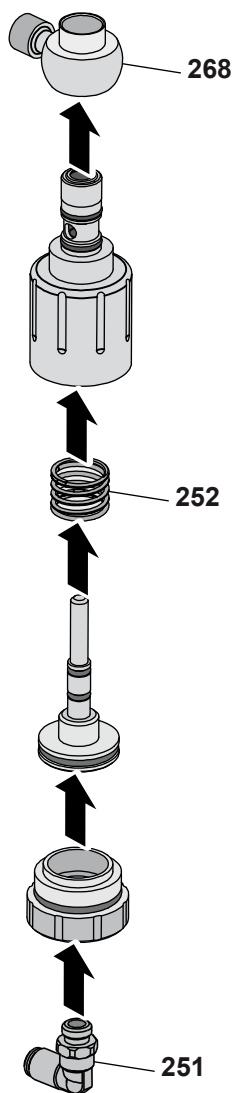

56

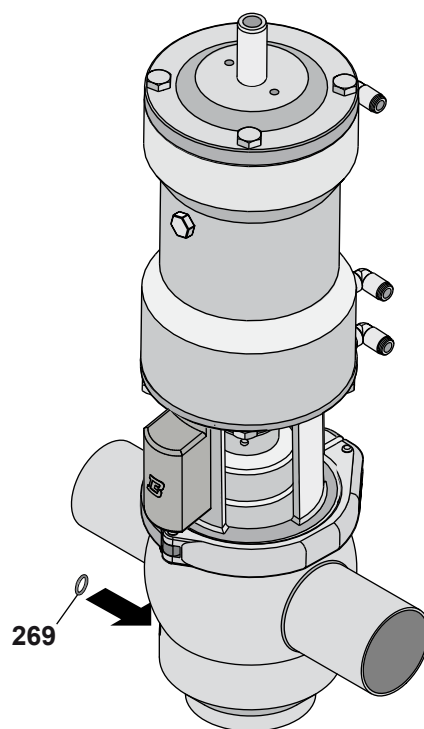

57

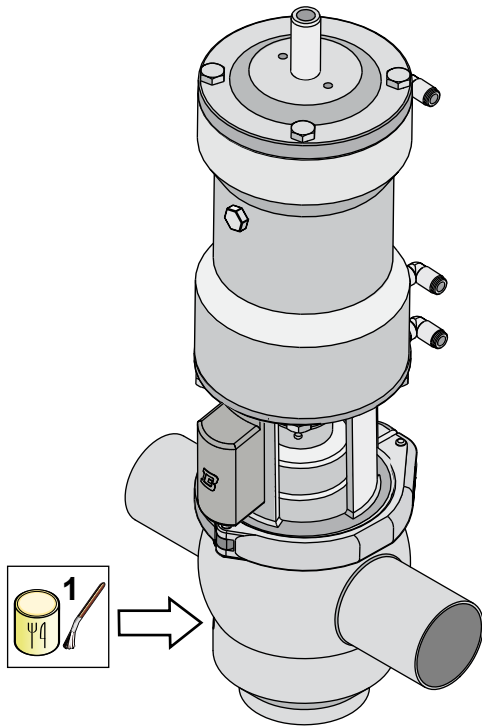

58

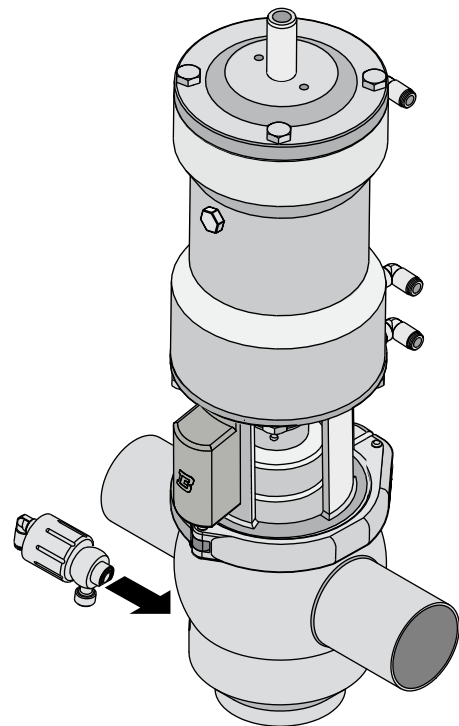

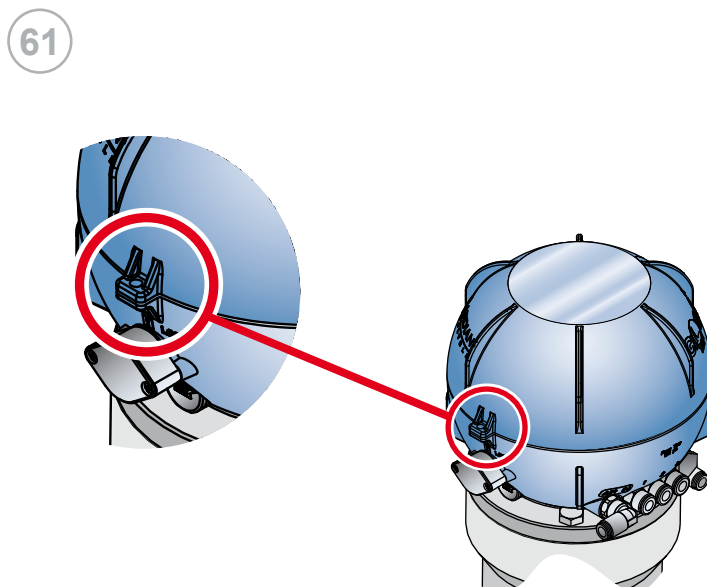
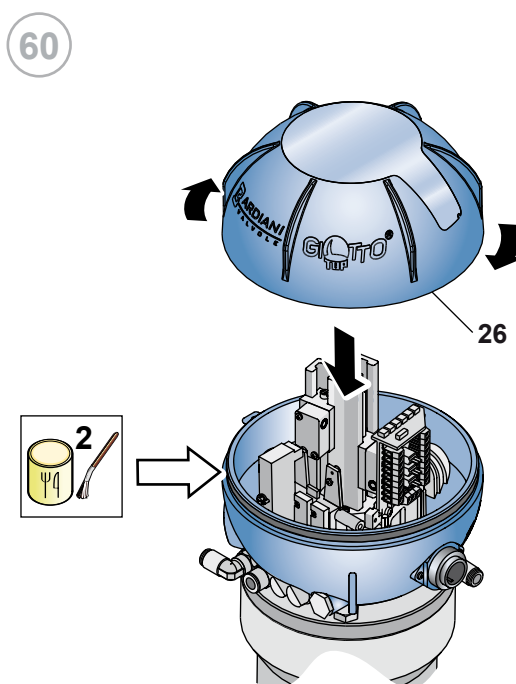
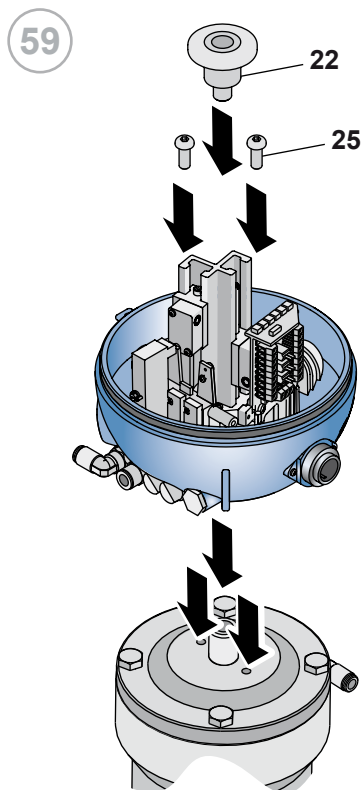

11 CE certificate



GB - EC Declaration of conformity - without electric components - A5-P-PRG-GB

EC DECLARATION OF CONFORMITY OF THE MACHINERY

(EC) 2006/42, Annex. II, p. 1 A

BARDIANI VALVOLE S.p.A.

Via G. di Vittorio 50/52 – 43045 Forno di Taro (Pr) – Italia

Declares

under its own responsibility that the machine:

Type:	PNEUMATIC VALVES
Model:	#####
Serial number:	#####
Function:	Fluid handling
Year of construction:	2018
Reference	#####

complies with all relevant provisions of the following EC directives:

(EC) 2006/42 MACHINERY

and the following harmonized standards, rules and / or technical specifications applied:

EN ISO 12100:2010

REGULATION (EC) 1935/2004 and subsequent amendments and additions with regard to steel and elastomers in contact with the product

Fornovo di Taro

20/09/2018

Legal Representative

A5-P-PRG-GB Ed. 1. Rev. 0

BARDIANI VALVOLE S.p.A.
Via G. di Vittorio 50/52
43045 Forno di Taro (Pr)

122D diagram B93J

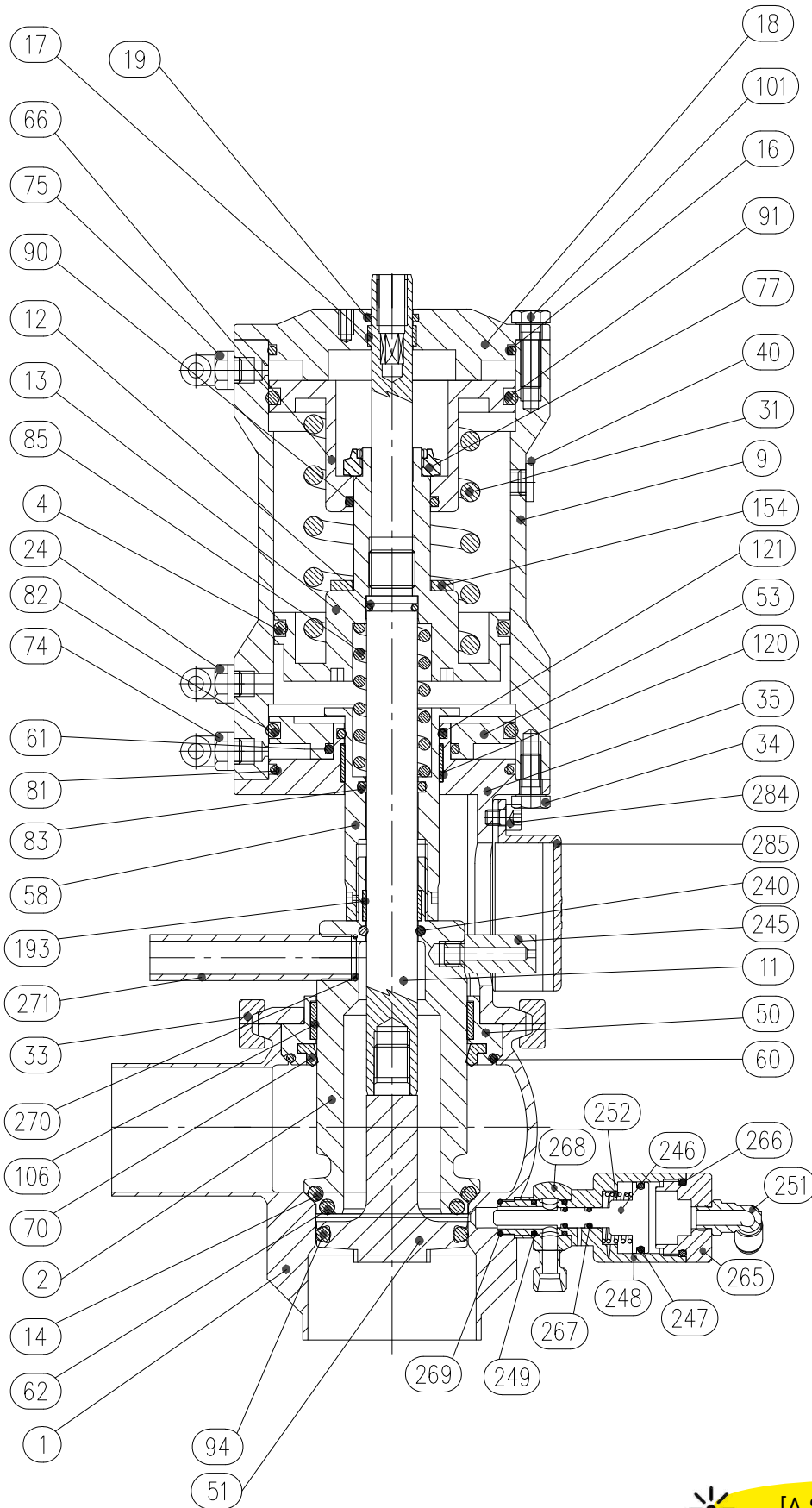

[A S B93JPG]

132D diagram B93JPG

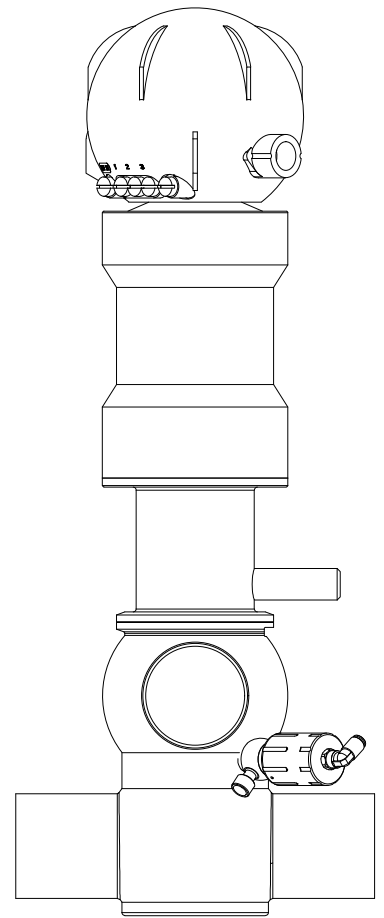
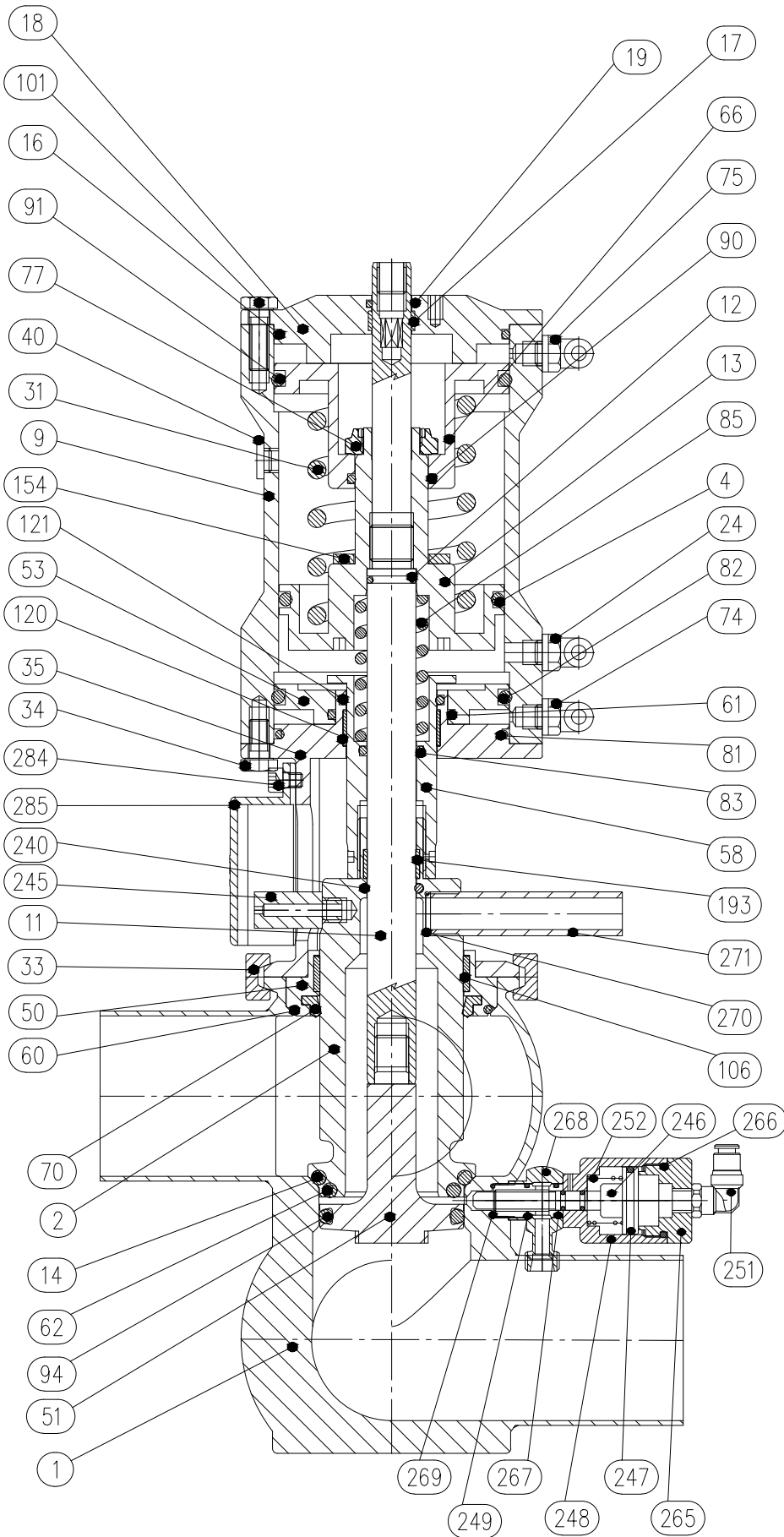

[A S B93JPG]

142D diagram B93JPG Reverse

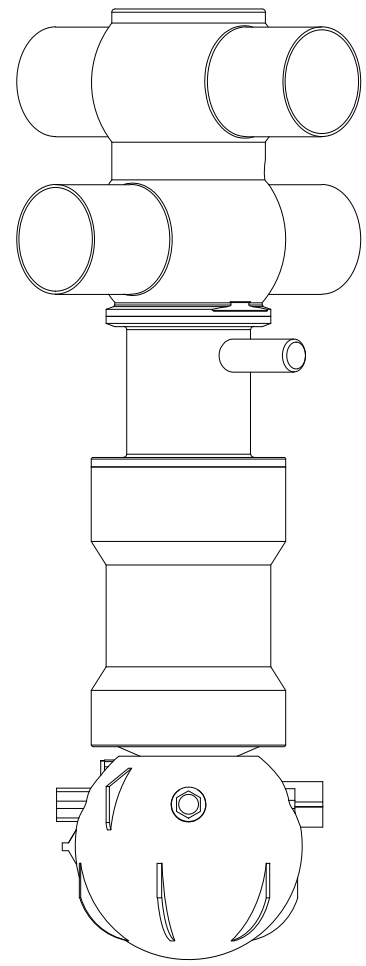
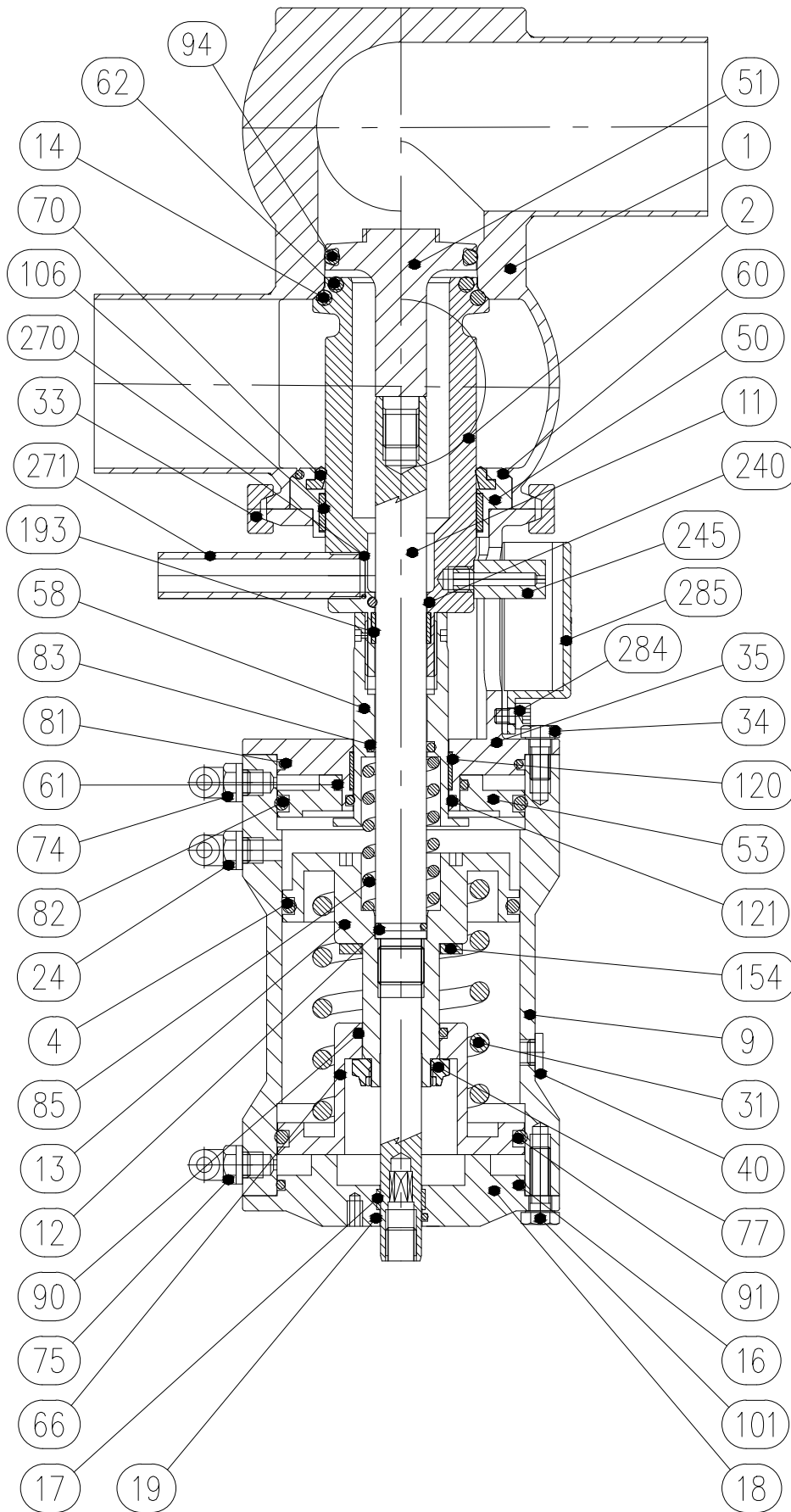

 [A S B93JPG]

15 Warranty

1. VALIDITY

Bardiani Valvole's Products are manufactured in compliance with the technical specifications laid out in their "Instruction, Use and Maintenance Manual" and are fully compliant with the directives specifically mentioned in these manuals.

Bardiani Valvole S.p.A. guarantees its own Products against any design and/or construction and/or material defects and/or faults for a period of 12 (twelve) months from the date of delivery.

Notification of any Product defects and/or faults must be sent in writing to Bardiani Valvole S.p.A. within 8 (eight) days from their detection, providing adequate documentation of the defect/fault encountered as evidence.

Services provided in the warranty period shall not result in an extension of the warranty beyond the stipulated 12 (twelve)-month period, as this warranty validity period is to be considered mandatory.

2. CONTENTS OF THE WARRANTY

Notwithstanding and without prejudice to the rights of the Buyer, which may be acknowledged by applicable law, this warranty is to be intended as limited, at the discretion of Bardiani Valvole S.p.A., to the repair and/or replacement of the Product and/or part of the Product and/or its components which is/are found to be defective due to design and/or manufacturing and/or material faults.

In the event of repair and/or replacement of the Product and/or any one of its parts and/or components, any returned item/s shall become the property of Bardiani Valvole S.p.A. and the relative shipping costs shall be charged to Bardiani Valvole S.p.A.

Bardiani Valvole S.p.A., shall be under no obligation to compensate for any immaterial and/or indirect damages and shall in no way be held liable for consequential damages and/or losses, such as (by way of example only), damages due to loss of business, contracts, opportunities, time, production, profits, goodwill, image etc.

No retailer or distributor or dealer or agent or representative or employee or person appointed by Bardiani Valvole S.p.A. is authorized to make any amendments and/or integrations and/or extensions to this warranty.

3. WARRANTY EXCLUSIONS

- Elastomers are expressly excluded from this warranty.
- This warranty does not cover design faults emerging whenever a Product is manufactured by Bardiani Valvole S.p.A. based on designs and/or technical specifications provided by the Buyer.
- Moreover this warranty excludes the following:
 - faults and/or defects resulting from incorrect and/or unsuitable and/or inadequate transportation of the Product;
 - faults and/or defects resulting from failure to comply with the indications laid out in the "Instruction, Use and Maintenance Manual" with regards to installation of the Product or in any event caused by incorrect and/or unsuitable and/or improper installation;
 - faults and/or defects resulting from failure to comply with indications laid out in the "Instruction, Use and Maintenance Manual" with regards to use and/or maintenance operations and/or storage of the Product or in any event caused by incorrect and/or unsuitable and/or improper use and/or maintenance operations and/or storage;
 - faults and/or defects due to normal wear and tear of the Product and/or its parts and/or its components;
 - faults and/or defects in the Product and/or its parts and/or its components for work and/or repairs being carried out by unskilled staff or staff that has not been authorised by Bardiani Valvole S.p.A.;
 - faults and/or defects in the Product and/or its parts and/or its components caused by its being dropped and/or banged and/or dented and/or misused and/or tampering and/or breakage and/or accidents and/or any other event caused by negligence and/or carelessness and/or neglect by the Buyer and in general for any causes not ascribable to design and/or manufacturing and/or material defects;
 - faults and/or defects in the Product and/or its parts and/or its components caused by other events beyond the control of Bardiani Valvole S.p.A., such as force majeure or unforeseeable circumstances.

16 Recommendations

- 1.** Consultation of the "Instruction, Use and Maintenance Manual" is mandatory prior to the installation, use and maintenance of all Products. All the information, indications, specifications, technical details provided herein are based on test data which the Manufacturer Bardiani Valvole S.p.A. holds to be reliable nevertheless the above is not deemed to be assumed as fully exhaustive inasmuch as not every possible use has been envisaged.
- 2.** All the illustrations and drawings provided are to be intended as indicative and therefore not binding, the illustrations being for presentation purposes only.
- 3.** Being as the conditions of Product use and applications cannot be controlled by Bardiani Valvole S.p.A., the Purchaser must ascertain suitability of the use he intends to make of the products beforehand and assume all risks and liabilities which may result from the same.
- 4.** Customer is strongly advised to consult Bardiani Valvole S.p.A.'s technical-commercial collaborators to request any specific information concerning the technical characteristics of the Products.
- 5.** The information provided in this manual refers to the standard products manufactured by Bardiani Valvole S.p.A. and therefore cannot be assumed to apply to customized products as well.
- 6.** Bardiani Valvole S.p.A. reserves the right to amend and/or integrate and/or update the data and/or information and/or technical details relative to Products at any time and without prior notice. Please visit the website, www.bardiani.com, where the latest updated of the "Instruction, Use and Maintenance Manual" can be found".
- 7.** The content and validity of the warranty covering the Products of Bardiani Valvole S.p.A are dealt with in the relevant section in the "Instruction, Use and Maintenance Manual" which constitutes an integral part of the Products themselves.
- 8.** The content and validity of the warranty covering the Products of Bardiani Valvole S.p.A are dealt with in the relevant section in the "Instruction, Use and Maintenance Manual" which constitutes an integral part of the Products themselves.

NOTES

NOTES

Empty rectangular area for notes.

Bardiani Valvole S.p.A.
via G. di Vittorio, 50/52 - 43045 Fornovo di Taro (PR) - Italy
tel. +39 0525 400044 - fax +39 0525 3408
bardiani@bardiani.com - www.bardiani.com