

Instruction, Use and Maintenance Manual

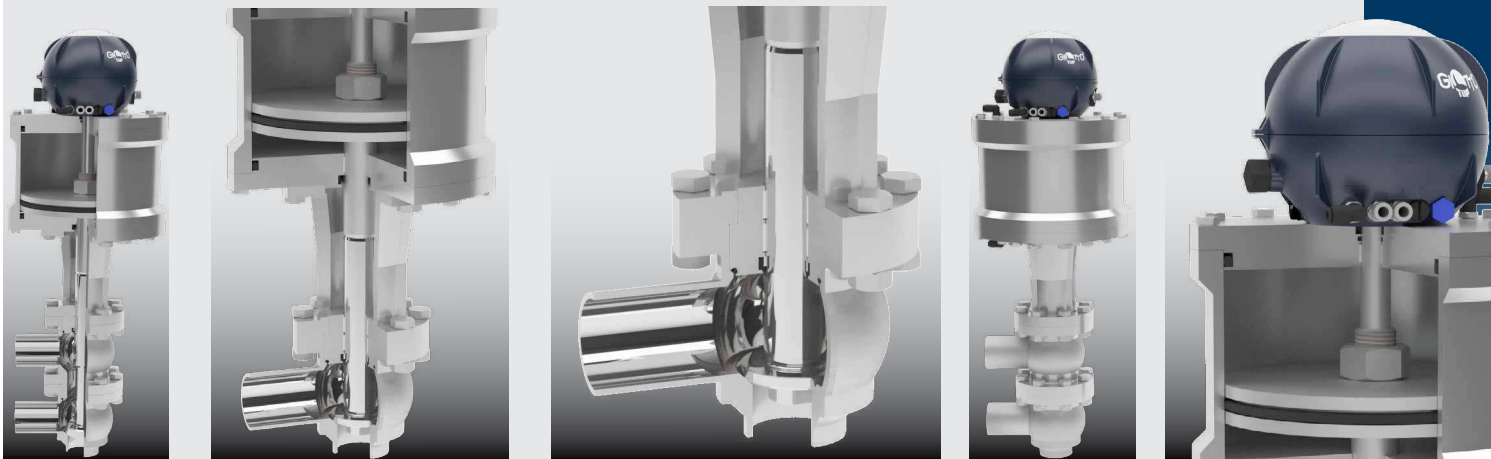

**HIGH-PRESSURE
PNEUMATIC VALVE**

**BBZQ - BBYQ -
BBZU**

Bardiani Valvole S.p.A.

via G. di Vittorio, 50/52 - 43045 Fornovo di Taro (PR) - Italy

tel. +39 0525 - Fax 0525 3408

bardiani@bardiani.com - www.bardiani.com

INDEX

1	Safety, Warning and Mandatory Signs	5
1.1	Operator training	8
2	General safety warnings	9
2.1	General safety warnings	9
2.2	Electrical devices	9
3	Technical data	10
4	Checking / Unpacking / Lifting	11
5	Installation	13
5.1	Body assembly BBZQ M8-LLL	18
6	Operation	19
7	Troubleshooting	20
8	Cleaning	21
9	Disposal	23
10	Maintenance	24
10.1	General maintenance	24
10.2	Scheduled maintenance	25
10.3	Tools useful for Disassembly/Reassembly	26
10.4	Pneumatic Valve BBZQ - BBYQ cylinder 108-156	27
10.5	Disassembly of the BBZQ - BBYQ cylinder 108-156	29
10.6	Assembly of the BBZQ - BBYQ cylinder 108-156	39
10.6.1	Select normally close or normally open cylinder	40
10.7	Pneumatic Valve BBZQ - BBYQ cylinder 108-156 Diverter	53
10.8	Disassembly of the BBZQ - BBYQ cylinder 108-156 Diverter	56
A	Disassembly Of The BBZQ - BBYQ LL - BBZQ P7 - BBYQ P7	58
B	Disassembly Of The BBZQ M8-LLL	65
10.9	Assembly of the BBZQ - BBYQ cylinder 108-156 Diverter	76
10.9.1	Select normally close or normally open cylinder	77
A	Assembly of the BBZQ - BBYQ LL - BBZQ P7 - BBYQ P7	86
B	Assembly of the BBZQ - M8-LLL	92
10.10	Pneumatic Valve BBZQ - BBYQ cylinder 207-360	102
10.11	Disassembly of the BBZQ - BBYQ cylinder 207-360	104
10.12	Assembly of the BBZQ - BBYQ cylinder 207-360	117
10.13	Pneumatic Valve BBZQ - BBYQ cylinder 207-360 Diverter	134
10.14	Disassembly of the BBZQ - BBYQ cylinder 207-360 Diverter	137
A	Disassembly of the BBZQ - BBYQ cylinder 207-360	139
B	Disassembly of the BBZQ - M8-LLL cylinder 207-360	144
10.15	Assembly of the BBZQ - BBYQ cylinder 207-360 Diverter	151
A	Assembly of the BBZQ - BBYQ cylinder 207-360 Diverter	159

B	Assembly of the BBZQ M8-LLL cylinder 207-360 Diverter	163
10.16	Idraulic damper for cilynder 207-360	169
10.17	Disassembly of idraulic damper for cilynder 207-360	171
10.18	Assembly idraulic of damper for cilynder 207-360	174
10.19	Pneumatic Valves BBZU	176
10.20	Disassembly of the BBZU	178
10.21	Assembly of the BBZU	182
11	Annexes	189
12	2D Diagram BBZQ cylinder 108-156	190
13	2D Diagram BBYQ cylinder 108-156	191
14	2D Diagram BBYQ M8 cylinder 108-156	192
15	2D Diagram BBZQ cylinder 108-156 Diverter	193
16	2D Diagram BBYQ cylinder 108-156 Diverter	194
17	2D Diagram BBYQ P7 cylinder 108-156 Diverter	195
18	2D Diagram BBYQ cylinder 108-156	196
19	2D Diagram BBZQ cylinder 207-360	197
20	2D Diagram BBYQ cylinder 207-360	198
21	2D Diagram BBYQ M8 cylinder 207-360	199
22	2D Diagram BBZQ cylinder 207-360 Diverter	200
23	2D Diagram BBYQ cylinder 207-360 Diverter	201
24	2D Diagram BBYQ P7 cylinder 207-360 Diverter	202
25	2D Diagram BBYQ M8-LLL cylinder 207-360 Diverter	203
26	2D Diagram BBYQ cylinder with damper 207-360	204
27	2D Diagram BBZQ cylinder 108-156 With Pressure Regulator	205
28	2D Diagram BBZU cylinder 108-156	206
29	2D Diagram BBZU cylinder 108-156	207
30	2D Diagram BBYQ cylinder 108-156 SPECIAL	208
31	2D Diagram BBYQ cylinder 108-156 Diverter SPECIAL	209
32	Warranty	210
33	Recommendations	211

MANUAL REVISION	DATE

INTRODUCTION

This "Instruction, Use and Maintenance Manual" has been prepared to provide guidance and recommendations to assist qualified skilled technicians in the understanding, running and maintenance of the Products supplied.

It forms an integral part of the Products supplied and must be read prior to any installation, operation and/or maintenance of all types of valves provided.

This manual must be saved for future reference and be kept readily available at the unit.

With regards to the use of valves compliant with EU Directive 2014/34/UE (ATEX), consultation of a specific manual is mandatory.

The essential characteristics of all types of valves described herein being consistent, the Manufacturer reserves the right to alter and or complement and or update at any time and with no obligation to notify so in writing, the data and or information relevant to the use of the valves described in this "Instruction, Use and Maintenance Manual".







A constantly updated version of this "Instruction, Use and Maintenance Manual" is available at the Manufacturer's website www.bardianivalvole.it.







Under no circumstance shall the Manufacturer be held liable for consequences resulting from failure and or improper use of the instructions contained in this Manual and relating to the installation, operating, maintenance and storage of the products.





All rights reserved.







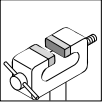
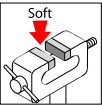

Full or part reproduction, transfer and or recording of any part of this "Instruction, Use and Maintenance Manual" by all means, whether it be electronic, on hard copy, mechanical or any other means or recording or reuse is strictly prohibited without the prior written consent of the Manufacturer and for any use other than that of the Buyer.

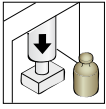
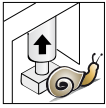
1 Safety, Warning and Mandatory Signs

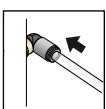
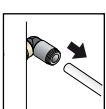
WARNING SIGNS		
Pictogram	Description	Notes
	WARNING! General	This tells the person in question that the operation described involves (when not performed in accordance with the relative safety regulations) the risk of personal injury.
	WARNING! Hand crushing	Exercise caution in executing the procedure Hand crushing hazard Never touch the moving parts if the actuator is supplied with compressed Air.
	WARNING! Heavy loads	Exercise caution in executing the procedure Heavy suspended loads.
	WARNING! Severe burns	Heat emission hazard Very hot surface, risk of severe burns
	WARNING! Risk of explosions	Take Care, risk of explosions
	WARNING! Do not disperse in the environment	Spent oil must be collected in appropriate containers and disposed of in accordance with the relative legislation in force

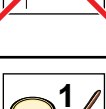
MANDATORY SIGNS (FOR THE OPERATOR IN CHARGE OF MECHANICAL MAINTENANCE AND THE OPERATOR IN CHARGE OF ASSEMBLY/DISASSEMBLY)		
Pictogram	Description	Notes
	OBLIGATION General	Special instructions must be followed to avoid injury to persons.
	PROTECTIVE GLOVES	Protective gloves must be available for handling objects which could cause hand injuries or when there is the possibility of coming into contact with harmful substances..
	HARD HAT	Hard hats must be available when lifting heavy parts.
	FOOTWEAR	Use safety footwear to protect against injuries caused by falling objects during maintenance operations (particularly when dismantling parts).
	SUITABLE CLOTHING	Suitable clothing such as overalls. It is strictly prohibited to wear clothes with large flapping sleeves and/or other loose items which could easily get caught up in machine parts.
	SAFETY GLASSES	Protective glasses must be available when there is the possibility of contact which harmful substances which could cause eye injuries.

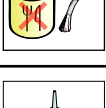
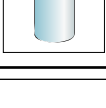
OPERATING SIGNS		
Pictogram	Description	Notes
	PERSONAL PERSONNEL	Dismantling/Assembling and maintenance operations must be carried out by expert technicians only.
	NOTE	Follow the indicated note with care
	ENVIRONMENTAL NOTE	Follow the regulations in force in the country of used governing waste disposal.
	CLAMP	Use of a clamp
	CLAMP WITH SOFT JAWS	Use of a clamp with jaws made from soft material
	ASSEMBLY / DISASSEMBLY SEQUENCE	Sequence of assembly disassembly operations

OPERATING SIGNS		
Pictogram	Description	Notes
	PRESS	Use of a press
	PRESS (release)	Use of a press Gradual release of the pressure force
	ELECTRICAL CONNECTION	Electrical connection to the control unit (consult the relative instruction manual).
	ELECTRICAL DISCONNECTION	Electrical disconnection from the control unit (consult the relative instruction manual).
	PNEUMATIC CONNECTION	Connection of the air to the valve.
	PNEUMATIC DISCONNECTION	Disconnection of the air from the valve
	DO NOT CONNECT AIR	Don't connect compressed air
	APPLICATION OF FOODSAFE GREASE	Use FOODLUBE HI-TEMP 2 grease or similar
	APPLICATION OF FOODSAFE GREASE	Use FOODLUBE Multi-paste grease or similar
	APPLICATION OF MULTIPURPOSE GREASE	Use AGIP GREASE MU EP 2 SE or similar
	THREADLOCK APPLICATION	Use SPEED BOND M500 threadlock or similar
	Oil	Use SPRINTER ADPV32 or similar
	OPTIONAL	

OPERATING SIGNS		
Pictogram	Description	Notes
	UTILIZZARE LE MANI	In tutte quelle fasi in cui è presente questo simbolo si possono utilizzare solo le mani per svitare / vitare i dispositivi indicati.

1.1 Operator training



All persons who have to work on the valve must be qualified to carry out the relative maintenance tasks. They must be informed as to the possible hazards involved and must observe all the safety instructions set out in this manual. Allow expert personnel only to work on the electrical components.

2 General safety warnings

2.1 General safety warnings



Intended use

Bardiani valves have been designed exclusively for moving fluids.

Prohibited use

The valve must not be used:

- for any operations different to those described under the heading “Intended Use”,
- for handling fluids different to the type specified by the manufacturer;
- for moving fluids at different pressures to those envisaged by the manufacturer and indicated in the valve's technical data.

Limitations on valve use

It is forbidden to:

- use the valve in a construction configuration different to the one envisaged by the manufacturer.
- use the valve where there is a risk of explosion and/or fire, unless envisaged by the manufacturer (if the valves are certified in accordance with Directive 2014/34/EU, please refer to the ATEX Manual)-;
- integrate other systems and/or equipment which were not considered by the manufacturer during the executive design phase,
- use the valve for purposes other than those specifically envisaged by the manufacturer.



WARNING!

The machine may not be used inside premises where there is a potentially explosive atmosphere or risk of fire unless otherwise stated by the manufacturer (in the case of valves certified in accordance with Directive 2014/34/EU please refer to the ATEX Manual).



BARDIANI VALVOLE S.p.A. declines all liability for installation, use or maintenance which fails to comply with the indications provided in this manual!

2.2 Electrical devices

(see the control unit manual)

3 Technical data

VALVE DATA		
Maximum pressure	150 bar (2173 psi) DN25 -80 / 1" - 3"	Maximum value based on type of fittings/connections
	55 bar (798 psi) DN100 / 4"	
Maximum seal pressure	See catalogue	
Storage temperature	from -10°C to +25°C	
Material in contact with the product	AISI 316L (1.4404). Check the resistance to corrosion in relation to products and detergents	
Gasket material in contact with the product	EPDM, FKM, P.T.F.E. and other gaskets on request. Check compatibility with products and detergents	
Surface finish in contact with the product	Ra 0.8 µm. Other finishes available on request	

VAPOUR BARRIER DATA	
Connectors	1/8" BSP
Steam maximum temperature	130°C (266°F)
Seals	FKM

PNEUMATIC ACTUATOR DATA	
Connectors	1/8" BSP
Pipe dimensions	6 mm external diameter, 4 mm internal diameter
Air pressure	from 6 bar (87 psi) to 8 bar (116 psi) for cylinder 108 - 156
	from 6 bar (87 psi) to 7 bar (101 psi) for cylinder 207 - 360
Air pressure	from 6 bar (87 psi) to 8 bar (116 psi)
External material	AISI 304L (1.4307)
Seals	NBR
Noise levels	76 dB
Electrical supply	See Giotto Top

GASKET MATERIALS COMPATIBILITY		
Product	FKM	EPDM
Temperature (applications with air)	from -10°C to +150°C	from -10°C to +140°C
Caustic soda 2%	30°C	60°C
Nitric Acid 2%	80°C	60°C
Saturated steam 125°C	To be checked	Suitable
Greases	Suitable	Unsuitable
Alcohols	Unsuitable	Suitable



The valve complies with PED 2014/68/EU directive, with special reference to Annex III, Module A, concerning internal manufacturing checks as indicated in the Conformity Assessment Procedures.



Valves with DN equal or smaller than DN32 are not included in compliance with Article 4, paragraph 3.

Valves designed for use with gases, liquefied gases, gases dissolved under pressure, vapours and also those liquids whose vapour pressure at the maximum allowable temperature is greater than 0,5 bar above normal atmospheric pressure (1 013 mbar) are included within the following limits:

- valves with DN40 or bigger with group 2 fluids.

The end user must carry out noise assessment testing once the valve has been installed in the plant.

In the event of any doubt, please contact Bardiani Valvole S.p.A.

4 Checking / Unpacking / Lifting

1. CHECK:

- Check the valve show no signs of damage caused during transport and that it corresponds with the order;
- Check the inside of the valve.



2. UNPACKING

The valve packaging is made up of cardboard, wood and plastic. The valve is mainly made up of metal materials. The gaskets are usually made from elastomers. Disposal must be in compliance with local legislation.

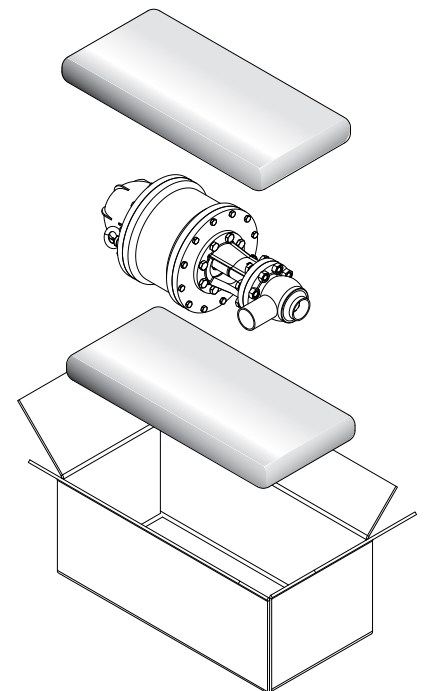
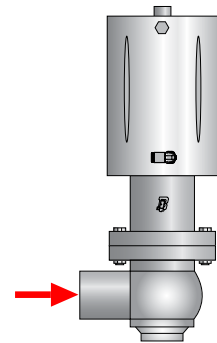



3. VALVE LIFTING:

Take care as to the type of valve you are handling. Based on the size there are different lifting procedures.



CAUTION!

Before lifting the valve, make sure there are no disassembled or separate valve parts which could fall off causing injury to persons and damage to the valve.

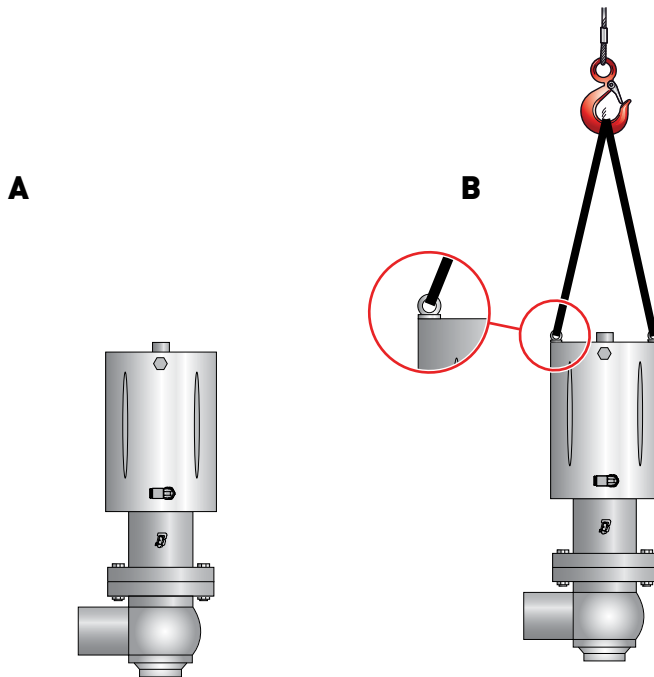

CAUTION!

The figures above are used purely to represent the methods and procedures for hoisting the valves.

Handle the device according to the regulations in force in the country of use.

Bardiani Valvole S.p.A. declines all liability for any damage to things and/or injuries to persons caused by improper and/or incorrect hoisting of the valve.

5 Installation



1. ELECTRICAL AND PNEUMATIC ENERGY SUPPLY

- Use expert personnel for installation/uninstallation operations;
- Check that the air pressure and quality are correct (see "Technical Data");
- Check the power supply to the control unit is correct (consult the relative instruction manual).

A = Upward movement of the valve member

B = Downward movement of the valve member

In single acting valves there is only one of the aforementioned commands.

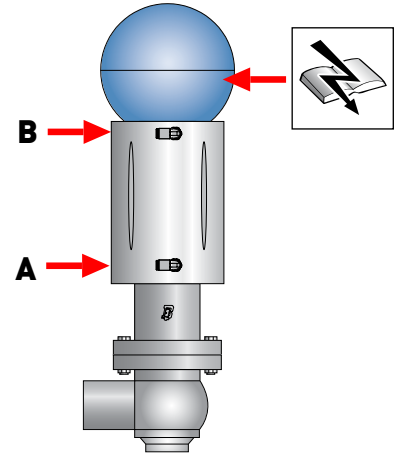

2. REDUCING THE STRESS TO WHICH THE VALVE IS SUBJECTED:

- Vibrations;
- Thermal expansion of the piping;
- Excessive welding;
- Overload.



CAUTION!

The seal seats may become deformed or cause valve malfunctioning.

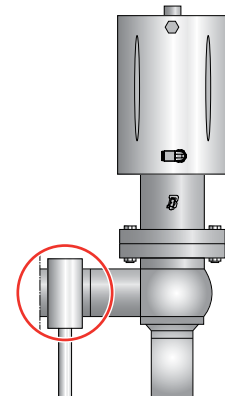

3. CORRECT DIRECTION OF FLOW:

Flow in the opposite direction to valve closure minimizes water hammer.

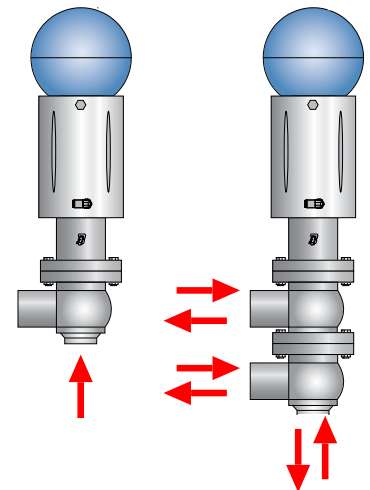

CAUTION!

Bardiani Valvole S.p.A. declines all liability for any damage to things and/or injuries to persons caused by any failure to correctly follow the installation procedures.



4. ELECTRICAL AND PNEUMATIC ENERGY SUPPLY BBZU DOUBLE ACTING

- Use expert personnel for installation/uninstallation operations;
- Check that the air pressure and quality are correct (see "Technical Data");
- Check the power supply to the control unit is correct (consult the relative instruction manual).

A = Upward movement of the valve member
 B = Downward movement of the valve member
 C = Upper lift

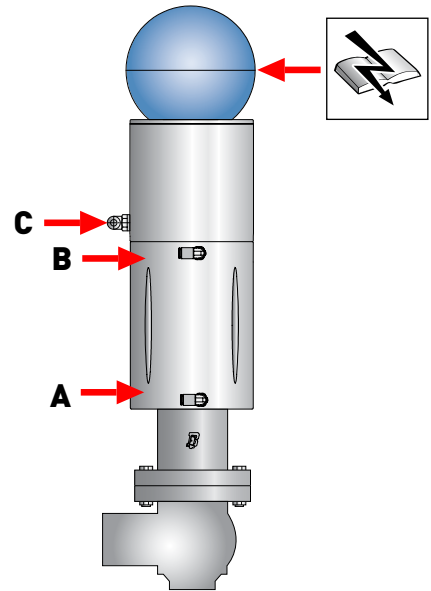

5. ELECTRICAL AND PNEUMATIC ENERGY SUPPLY SINGLE ACTING

- Use expert personnel for installation/uninstallation operations;
- Check that the air pressure and quality are correct (see "Technical Data");
- Check the power supply to the control unit is correct (consult the relative instruction manual).

A = Upward movement of the valve member
 B = Upper lift

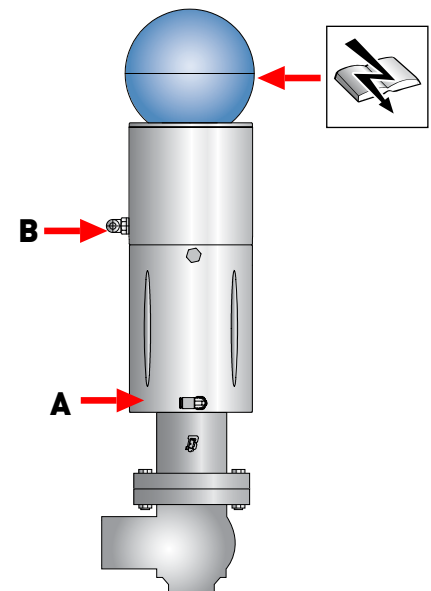



6. VALVE CONNECTIONS/CONNECTORS:

If the valve is fitted with connectors, you may proceed with installation. Correctly insert the gaskets and tighten the connectors.



7. WELDING THE VALVE BODY ONTO PIPING:

Remove the body from the rest of the valve before proceeding with welding operations. Please refer to the following pages in this manual.



WARNING!

Hand crushing hazard. During operation there is a risk of crushing inside the valve body in the area between the actuator and the valve body.



8. MINIMUM MAINTENANCE CLEARANCES:

Make sure there is enough room around the valve for it to be disassembled (with the control unit installed).

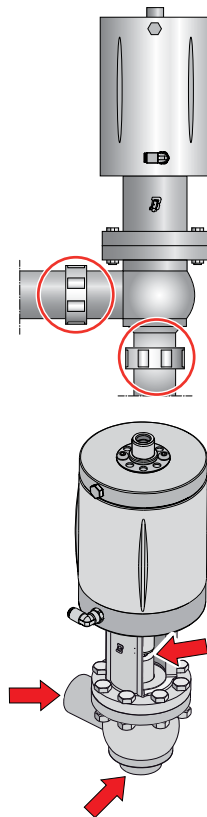

BBZQ (cyl. 108-156)			
Valve dimension (DN)	A (mm)	B (mm)	C (mm)
25-40	225	225	225
50	283	283	283
65	240	240	240
80	315	315	315
100	240	315	315

BBZQ (cyl.207-360)			
Valve dimension (DN)	A (mm)	B (mm)	C (mm)
25-40	275	275	275
50	344	335	335
65	290	305	305
80	377	366	366
100	310	385	385

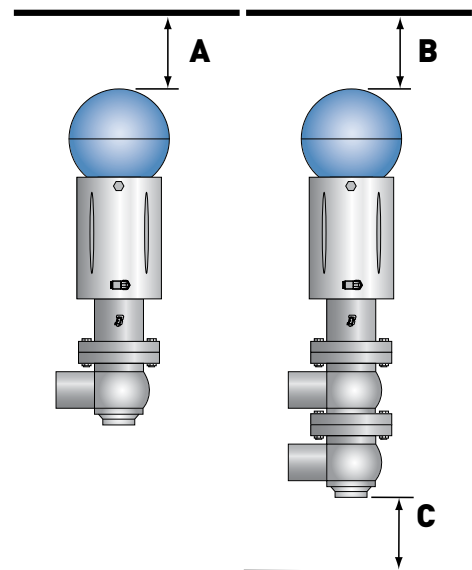

Once valve installation has been completed, remove the eyebolts and put the screws back in

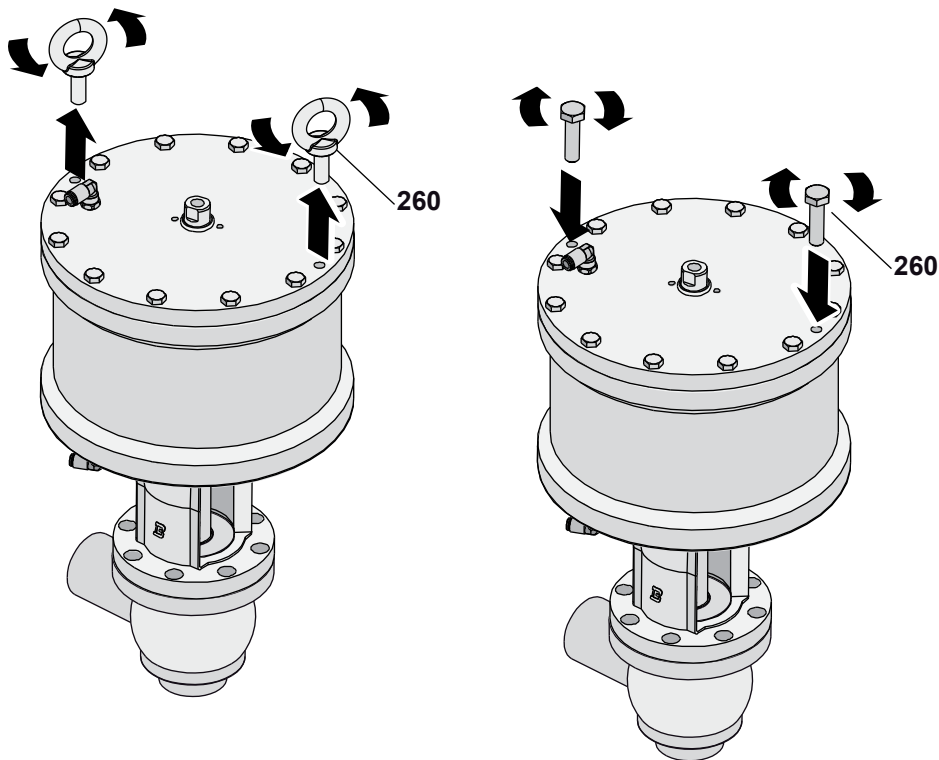
**CAUTION!**

Bardiani Valvole S.p.A. declines all liability for any damage to things and/or injuries to persons caused by any failure to correctly follow the installation procedures.

Assembly with overlapping connections

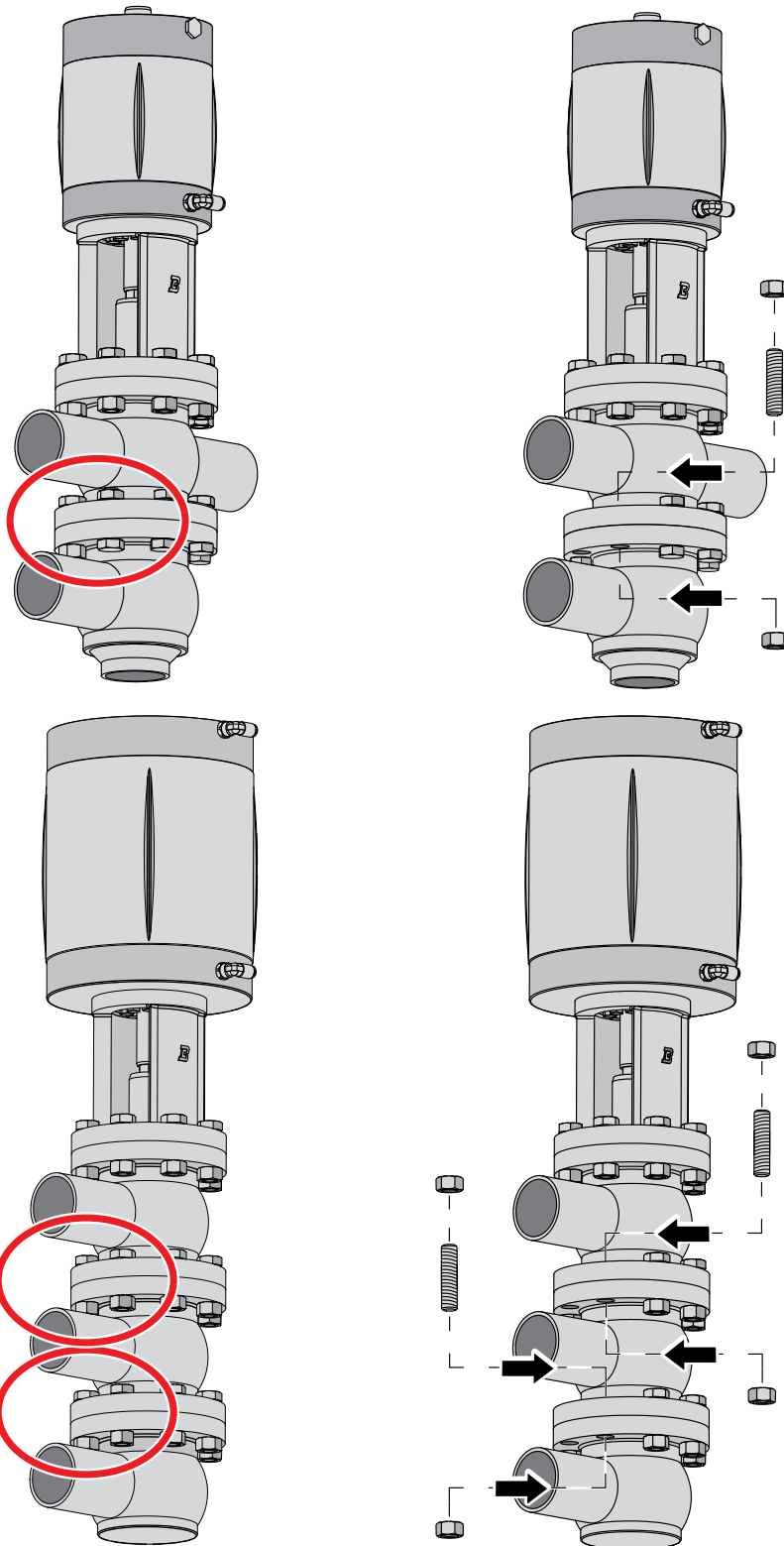

DN	
25--40	M10X50
50	M12X55
65	M14X55
80	M14X55
100	M14X55

(Not part of our supply)

5.1 Body assembly BBZQ M8-LLL

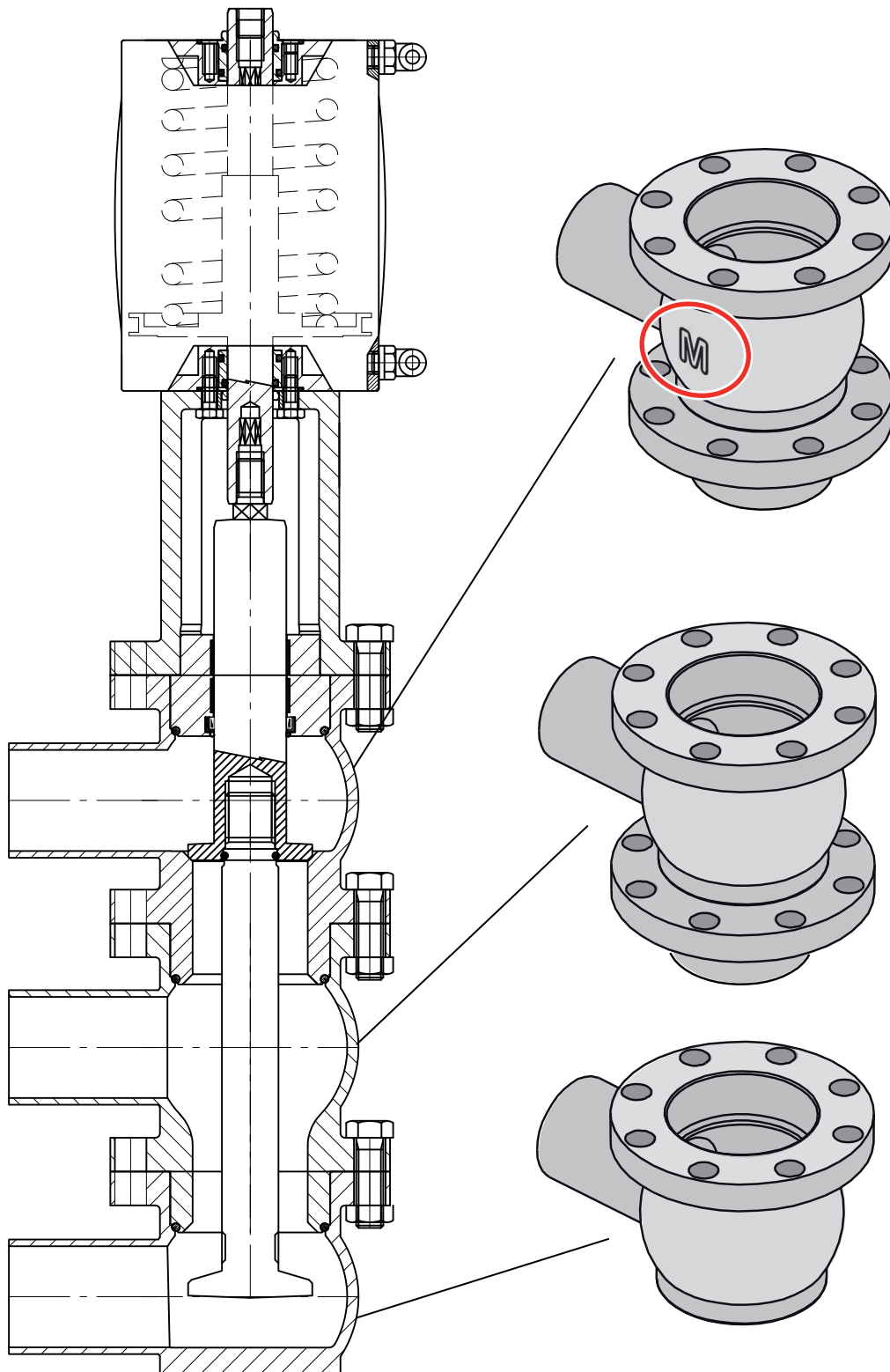

6 Operation



1. VALVE INSPECTION BEFORE OPERATION:

- Supply air to the actuator;
- Power the valve (via the control unit);
- Open and close the valve several times;
- Check that the valve works correctly and accurately.

A = Upward movement of the valve member

B = Downward movement of the valve member

In single acting valves there is only one of the aforementioned commands.



WARNING!

Hand crushing hazard. During operation there is a risk of crushing inside the valve body in the area between the actuator and the valve body.

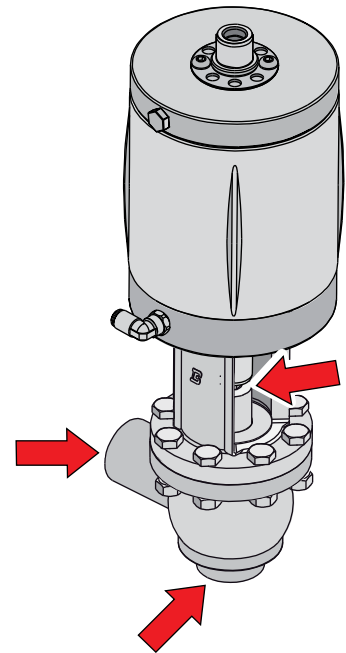
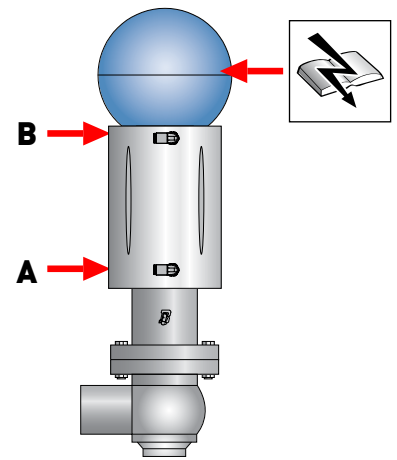

7 Troubleshooting



PROBLEM	POSSIBLE CAUSE	POSSIBLE SOLUTION
External leak	Worn gasket	Replace the seal
Leaks inside the closed valve caused by normal wear		
External leak	Excessive pressure	Replace with a gasket of a different type of elastomer
	Excessive temperature	
Premature leaks inside the closed valve	Aggressive fluids	Modify the operating conditions
	Too many commands active	
Difficulty opening and closing	Incorrect type of elastomer used for the gaskets	Replace with a gasket of a different type of elastomer
	Incorrect positioning of the actuator	Install the actuator correctly
	Incorrect operation of the actuator	Switch from NC to NA or vice versa
	Impurities in the actuator	Actuator inspection and maintenance
	Incorrect valve body positioning	Disassemble and correctly reposition the valve body

8 Cleaning



1. VALVE CLEANING WITH DETERGENTS:

The system in which the valve is installed must be cleaned by expert personnel in observance of the following:

- Abide by the indicated detergent concentration values;
- Observe the instructions provided by the detergent manufacturer.
- Always wear protective safety glasses and gloves.



IMPORTANT!

- Accurately dose detergents to avoid excessive concentration;
- Always rinse thoroughly with clean water after washing.
- Check compatibility of valve materials.



WARNING!

Burns hazard. The valves and piping may be very hot. Wear protective gloves



WARNING

After installing a new or serviced valve, perform an internal washing cycle before using the piping for food liquids. If there has been any welding work, passivation treatment must be carried out.

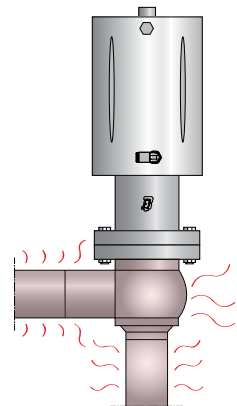
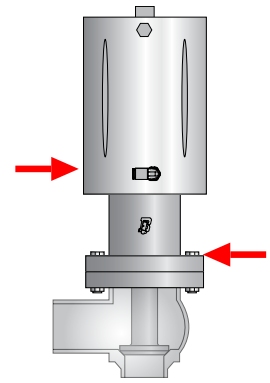

EXAMPLE OF INTERNAL WASHING CYCLE (CIP)		
Phases	Temperature °C	Washing product
Initial rinse	Environment	Chlorine- and chloride-free water
Washing	70 °C	Caustic soda (NaOH) at 1%
Intermediate rinse	Environment	Chlorine- and chloride-free water
Washing	70 °C	Nitric acid (HNO3) at 0.5%
End rinse	Environment	Chlorine- and chloride-free water

Recommended washing product velocity = 2m/s

	EPDM	FKM
Product		
Max temperature	95 °C	95 °C
Minimum temperature	-20 °C	-5 °C

	EPDM	FKM
Steam		
Max temperature (during working)	130 °C	120 °C
Max temperature (for a period of time 15-20 min)	150 °C	140 °C

	EPDM	FKM
Sodium hydroxide		
Diluted cleaning solution	<5%	<5%
Minimum temperature	1 °C	1 °C
Max temperature	80 °C	80 °C

	EPDM	FKM
Acid (Nitric / Phosphoric / Peracetic acid)		
Diluted cleaning solution	<2%	<2%
Minimum temperature	1 °C	1 °C
Max temperature	40 °C	65 °C

	EPDM	FKM
Disinfection		
Diluted disinfectant (based on peracetic acid)	<0,7%	<0,7%
Minimum temperature	1 °C	1 °C
Max temperature	30 °C	30 °C

9 Disposal



At the end of its service life, the device must be recycled in accordance with the legislation in force in the country of valve use.

Any hazardous residues must be taken into consideration and adequately handled.

The valve is made of AISI 316L and AISI 304 stainless steel, elastomers (gaskets), plastic (control unit) and electrical components (terminal boards, solenoid valves, sensors).

Adhere to the following steps before disconnecting the valve and refer to the heading "General Maintenance".

- make sure the line on which the valve is installed in is not in use
- empty the line on which the valve is installed and clean if necessary
- disconnect the air supply if it is not required during dismantling
- disconnect the valve from the power supply
- remove the valve from the system
- move the valve in observance of the rules set out in the heading "Lifting"
- to dismantle the valve, refer to the heading "Disassembly"

10 Maintenance

10.1 General maintenance



1. MAINTENANCE PRECAUTIONS

Maintenance operations must be carried out by expert technicians only.



WARNING!

Maintenance operations must be carried out with the line stopped and all utilities (electricity, compressed air) disconnected.

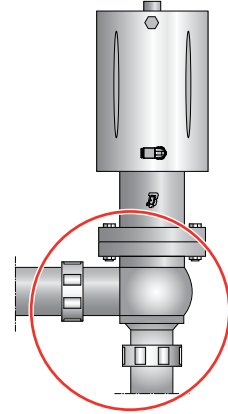

WARNING!

Always discharge the fluid pressure in the valve and piping before disassembling the valve.

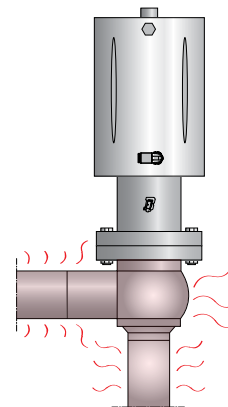

WARNING!

Burns hazard. The valves and piping may be very hot. Wear protective gloves



2. CLEANING AWAY DEPOSITS:

- Thoroughly wash and clean all the valve parts before disassembly;
- Pay attention to any possible detergent or other aggressive fluid deposits (see "Cleaning");
- Always use protective safety glasses and gloves when required.

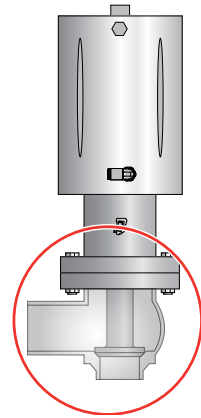

WARNING!

Hand crushing hazard. During operation there is a risk of crushing inside the valve body in the area between the actuator and the valve body.

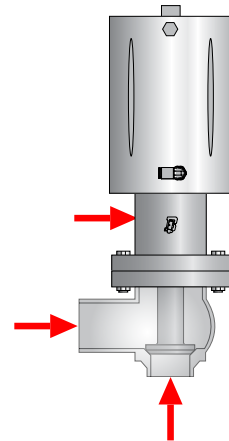

3. REPLACEMENT OF WORN VALVE PARTS:

Always use original spare parts

10.2 Scheduled maintenance

SCHEDULED MAINTENANCE	VALVE GASKETS	ACTUATOR GASKETS
Periodical	Replace after 12 months	Replace after 24 months
In the event of leaks	Replace at the end of the day	Replace in the event of leaks
Preventive	Check correct operation and that there are no leaks	Check correct operation and that there are no leaks
	Record the actions carried out	Record the actions carried out

10.3 Tools useful for Disassembly/Reassembly

TOOLS	DN25	DN32	DN40	DN50	DN65	DN80	DN100
	✓						
	4 - 6 - 8						
	10-12 -13-19 -24	10-12-13-17- 19-24	10-12- 13-15- 17-19- 24	10-12- 13-15- 17-19- 22-24		10-12-13-15- 19-21-22-24	
	✓						
	✓						
	BETA 99ST 35-50						

10.4 Pneumatic Valve BBZQ - BBYQ cylinder 108-156

NO.	DESCRIPTION
1	Lower body
2	Shutter
9	Cylinder
10	Bush
14	Sealing ring
17	Bush
24	Air connector
28	Shutter nut
34	Screw
35	Assembly
40	Cap
45	Steam barrier
47	Sealing ring
50	Gasket holder disc
57	Sealing ring
59	Screw
110	Screw
120	Bush
156	Sealing ring
157	Sealing ring
196	Steam connection
197	Sealing ring
205	Nut
274	Sealing ring
275	Sealing ring
276	Sealing ring
277	Sealing ring
295	Bush

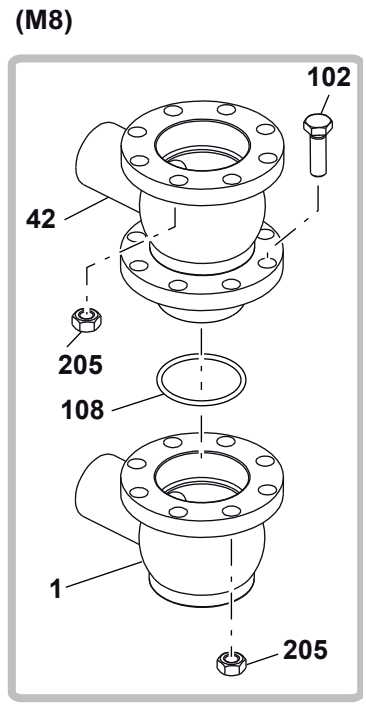
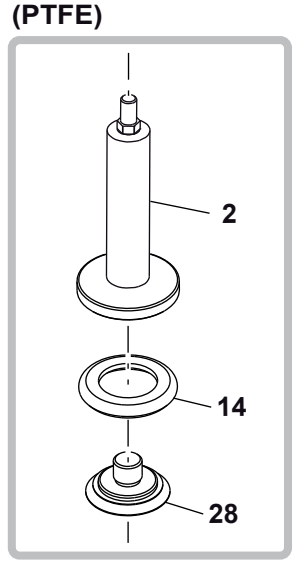
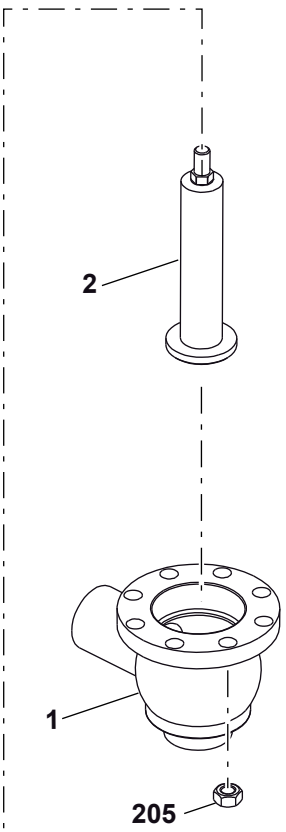
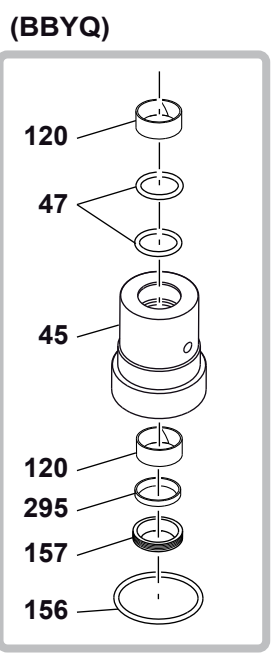
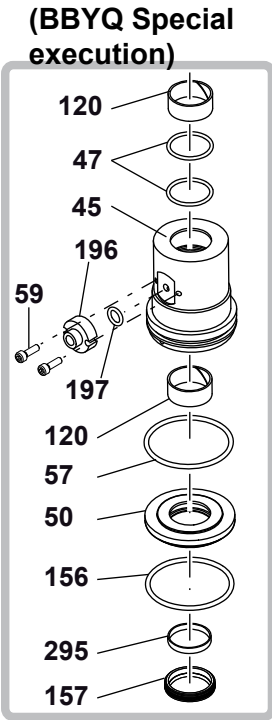
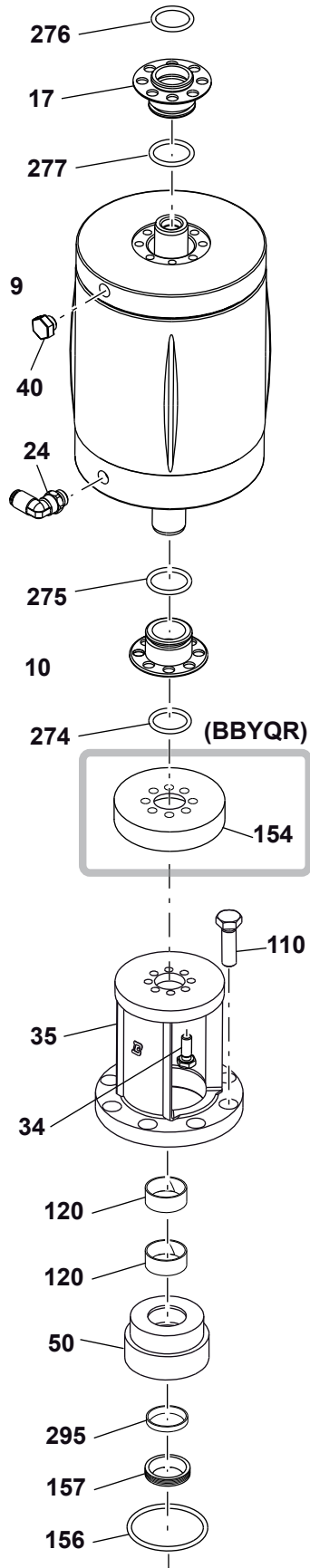

10.5 Disassembly of the BBZQ - BBYQ cylinder 108-156

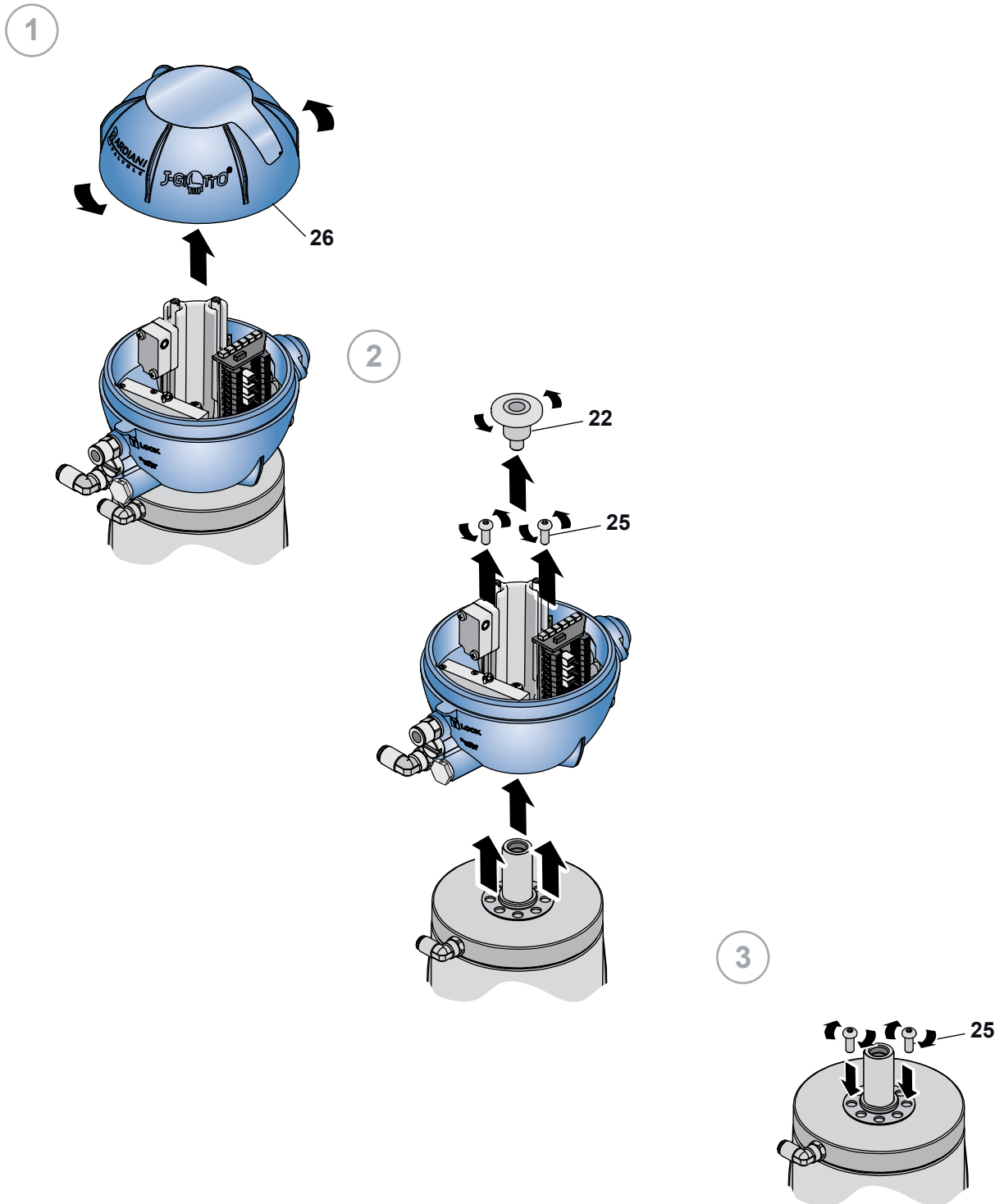

(Normally closed)

1 a

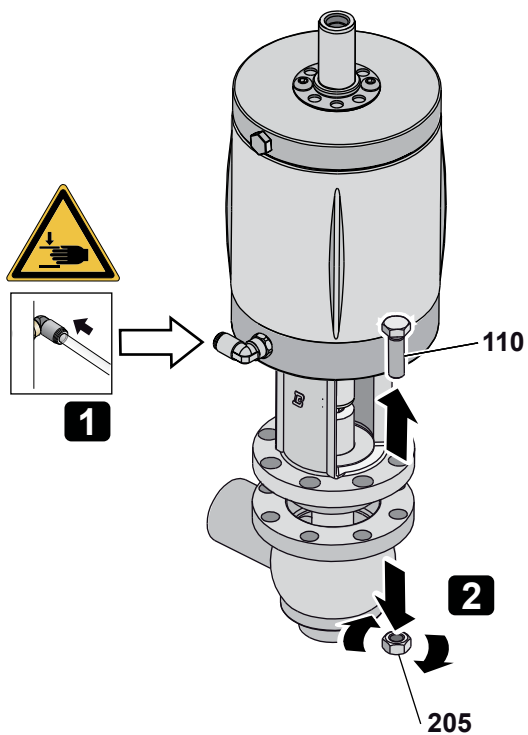

2 a

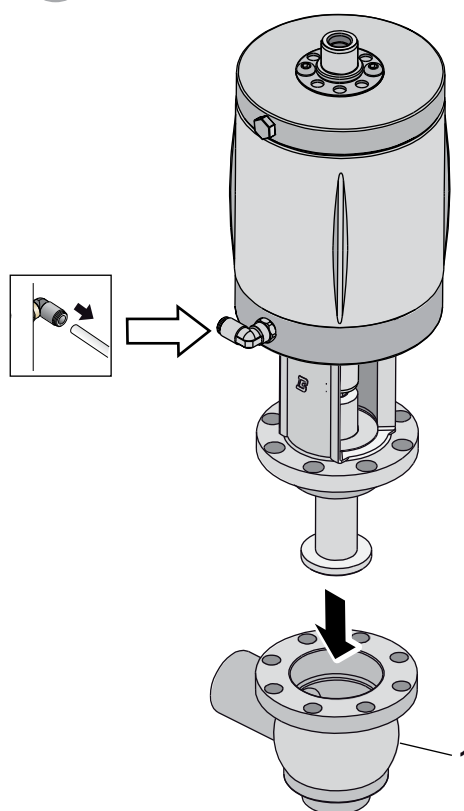

(Normally open or double acting)

1-b

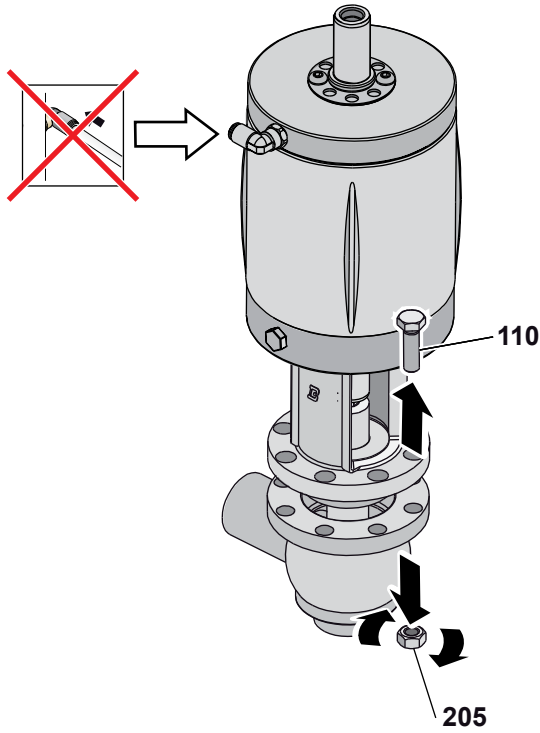

(M8 Normally closed)

1 C

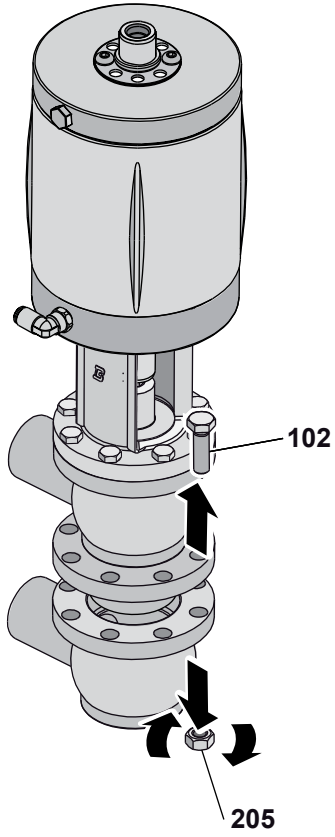

2 C

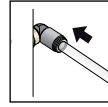

1

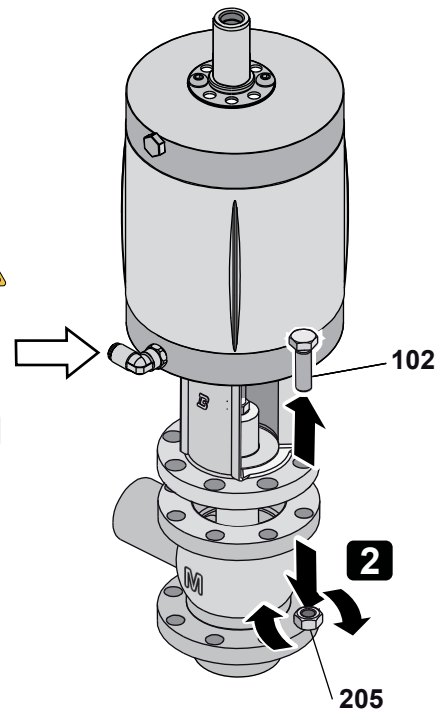

3 C

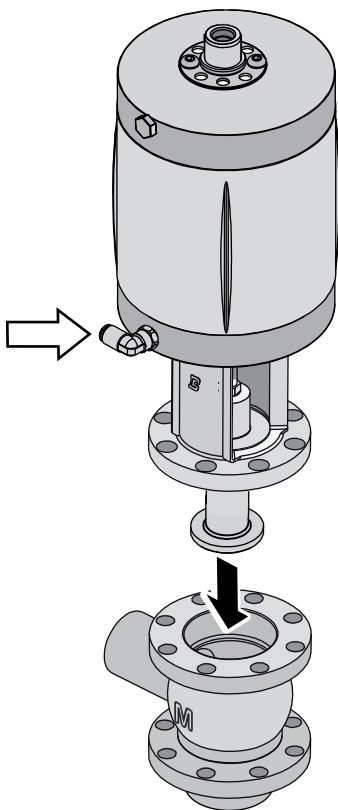
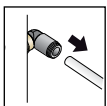

(M8 Normally open or double acting)

2-d

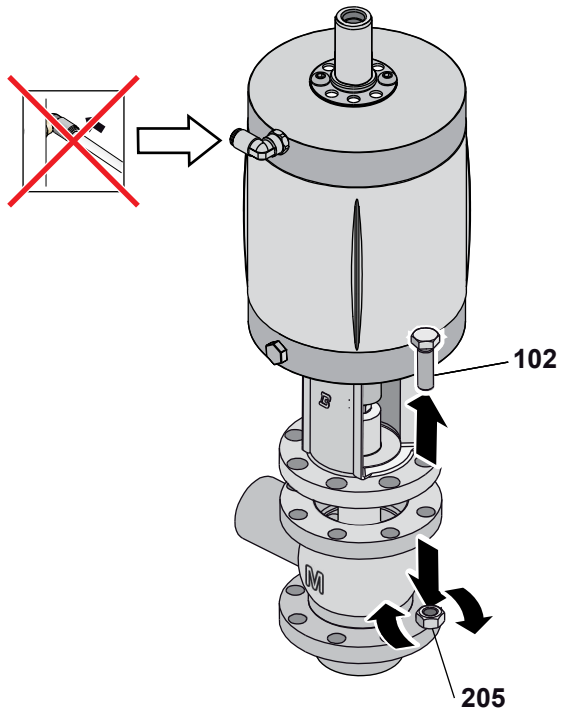

3-d

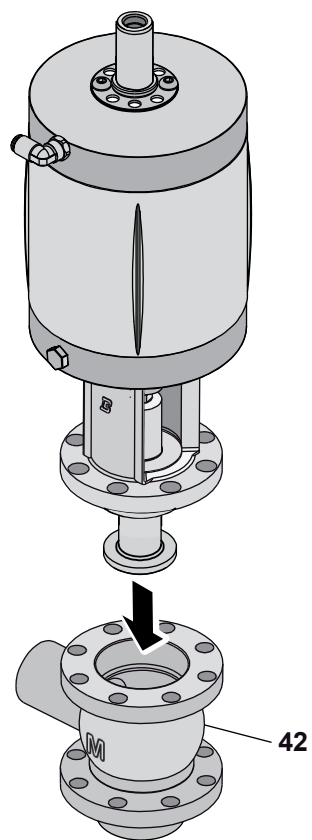

4

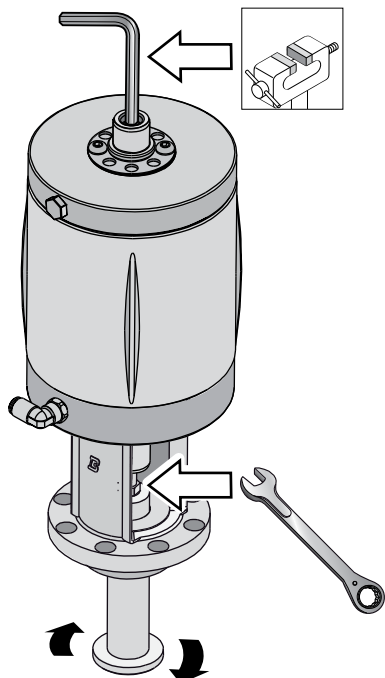

5

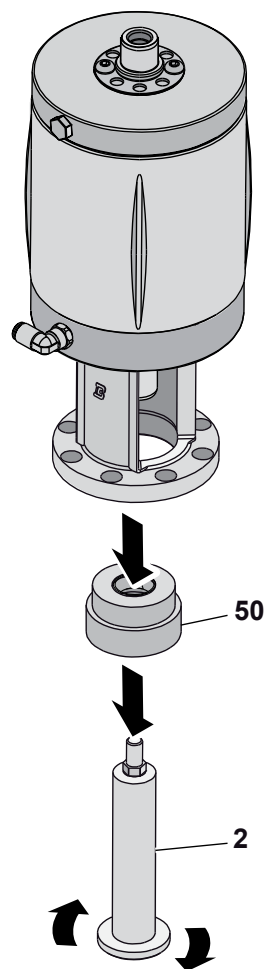

(BBYQ)

5-d

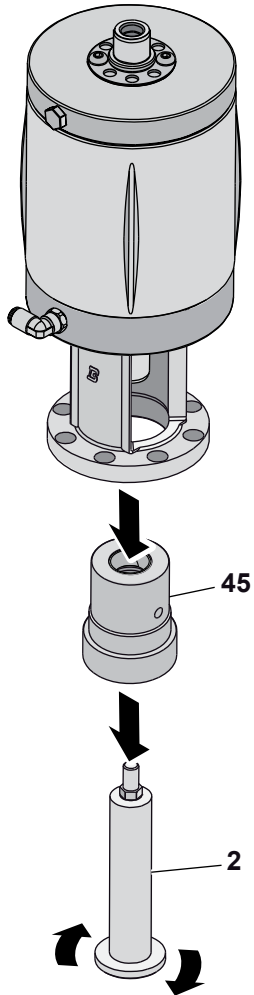

(BBYQ Special execution)

5-f

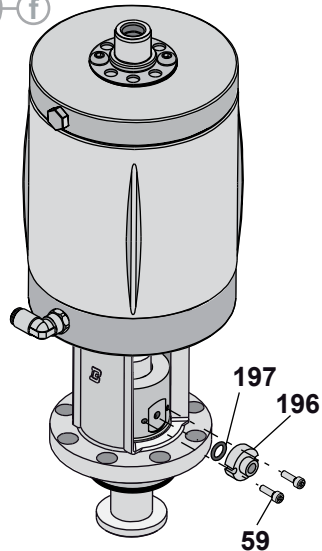

6-f

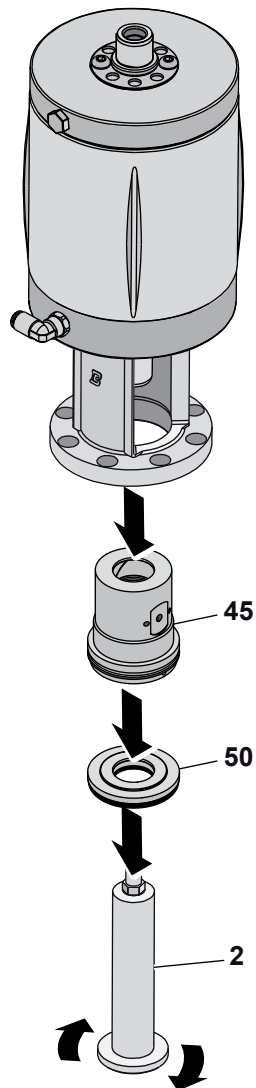

(P.T.F.E.)

7-e

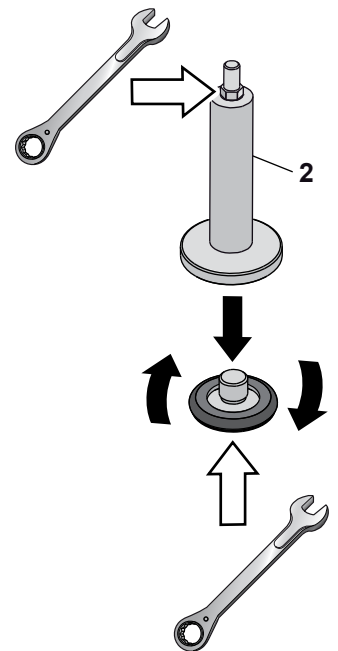

8-e

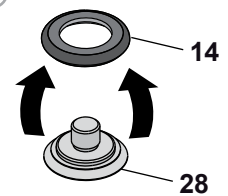

9

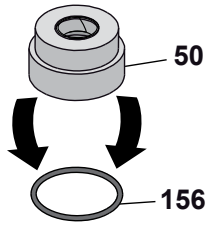

10

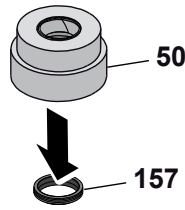

11

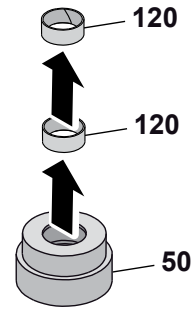

(BBYQ)

9-d

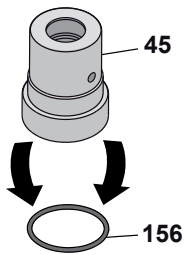

10-d

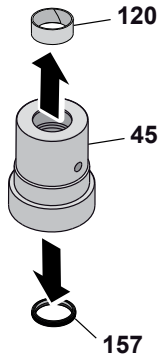

11-d

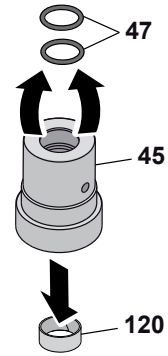

(BBYQ Special execution)

9-f

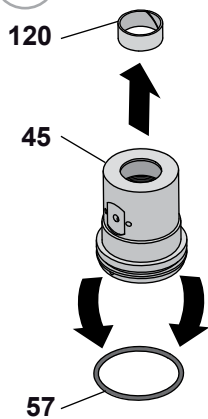

10-f

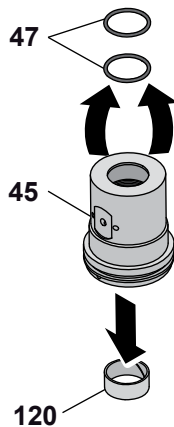

11-f

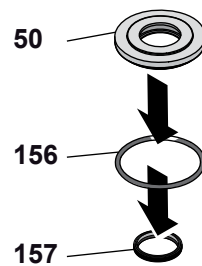

12

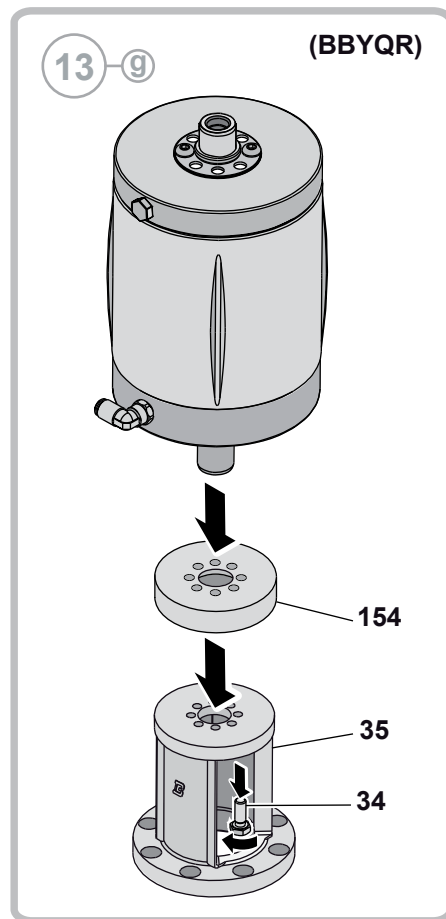
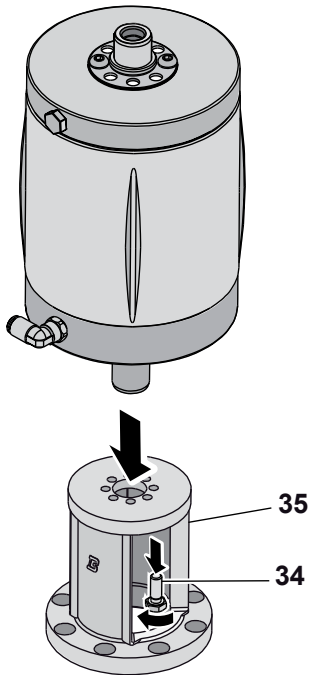

13

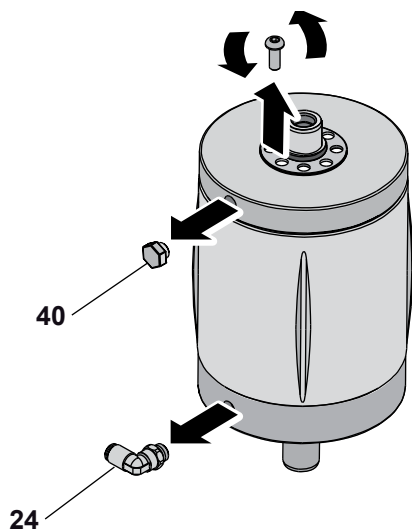

14

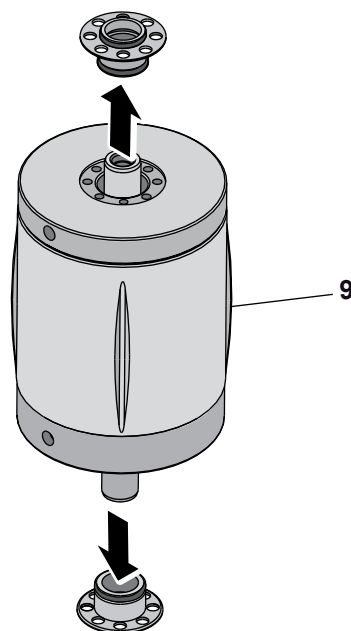

15

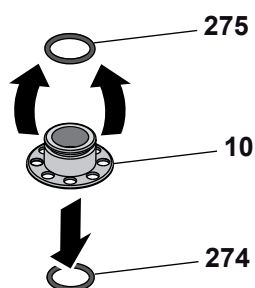

16

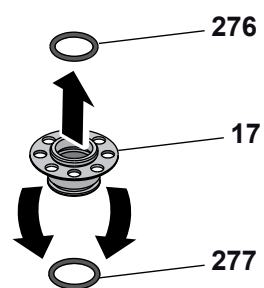

17

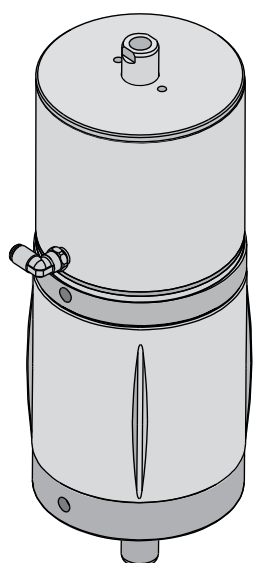

[BBZU]

10.6 Assembly of the BBZQ - BBYQ cylinder 108-156

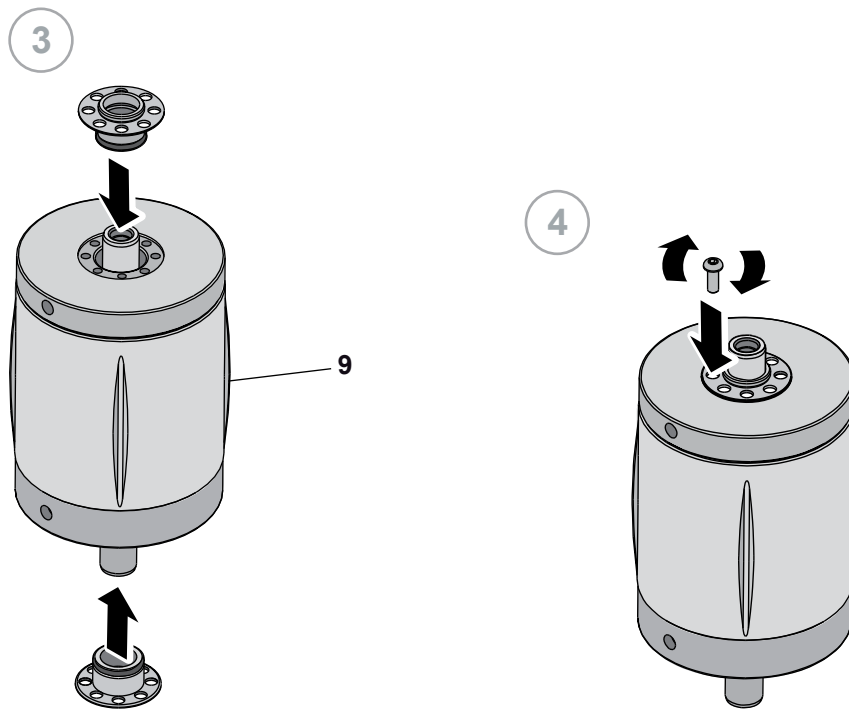
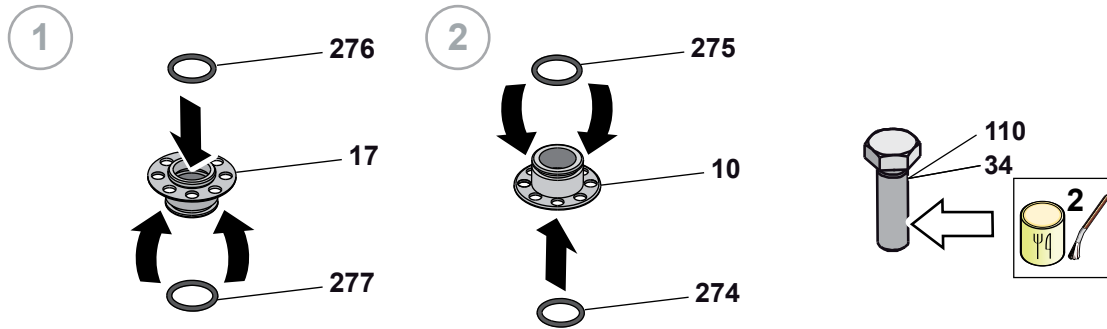

10.6.1 Select normally close or normally open cylinder

5

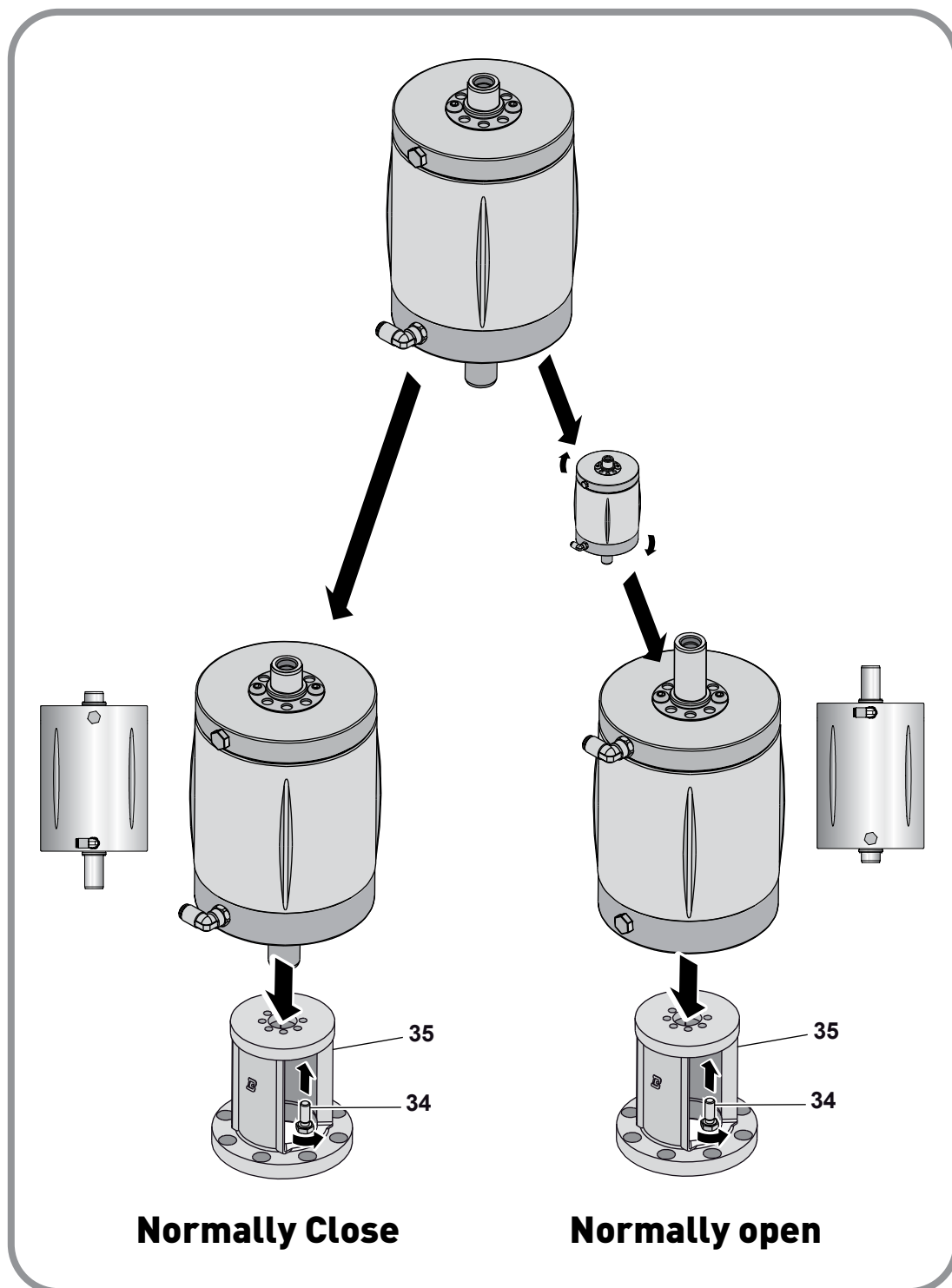

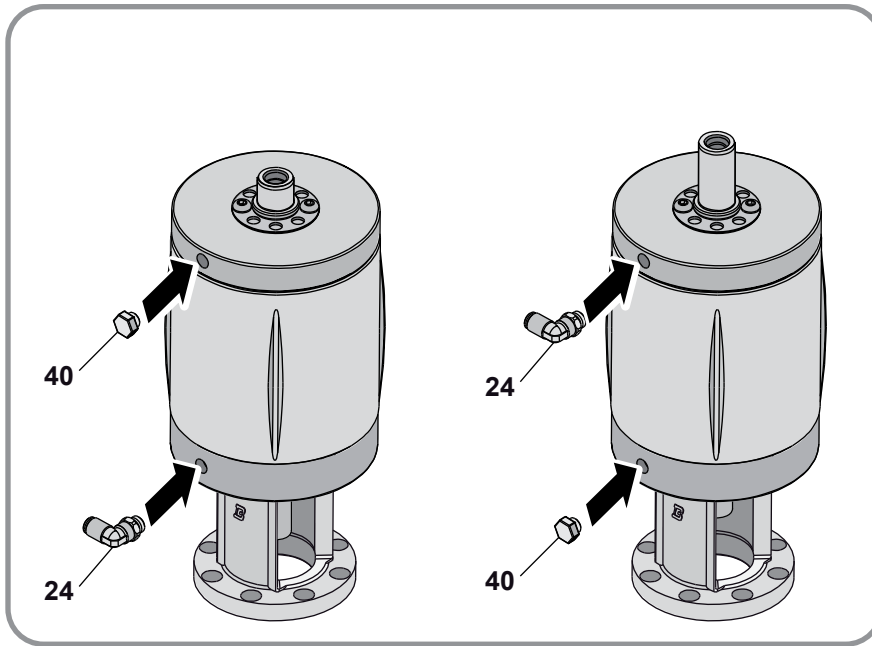

6

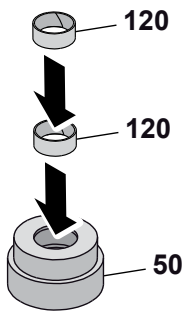

7

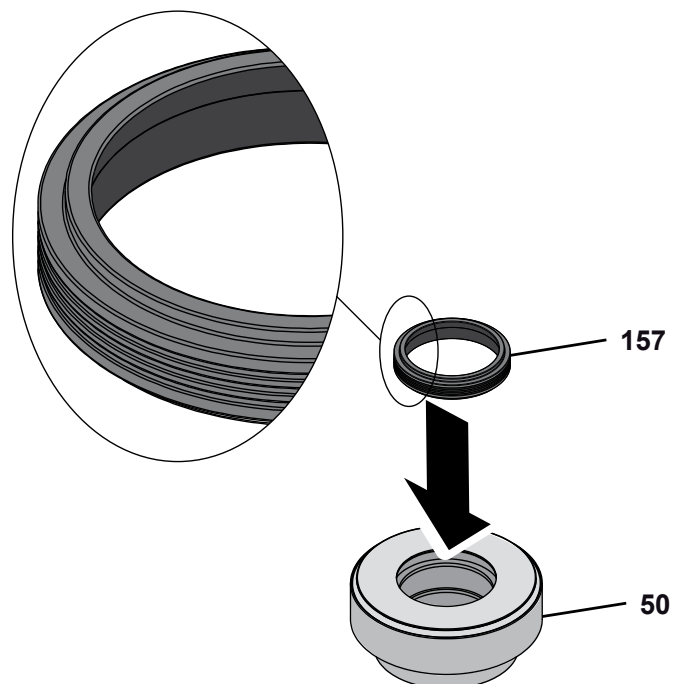
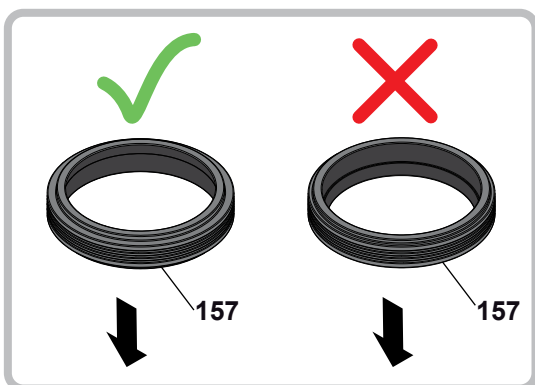

8

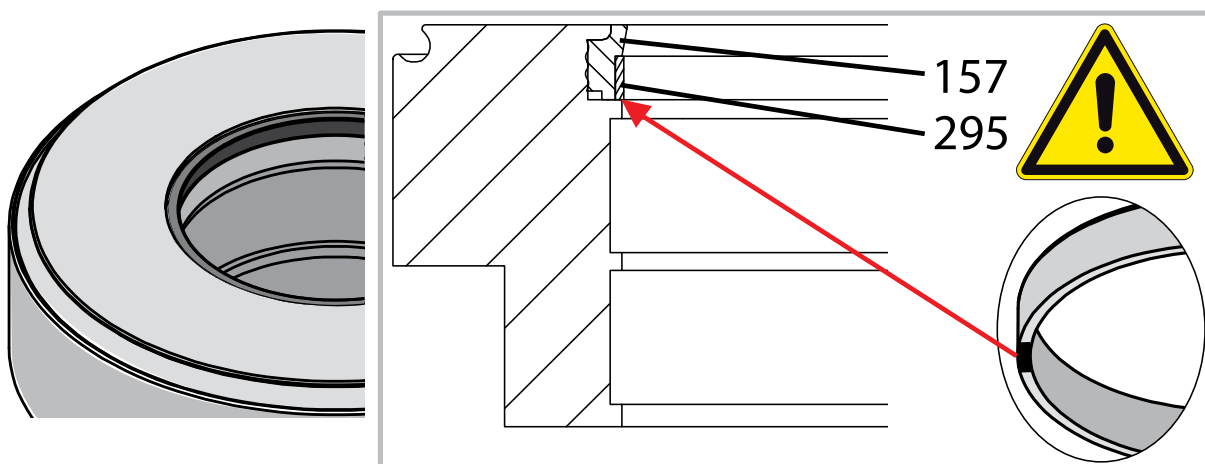
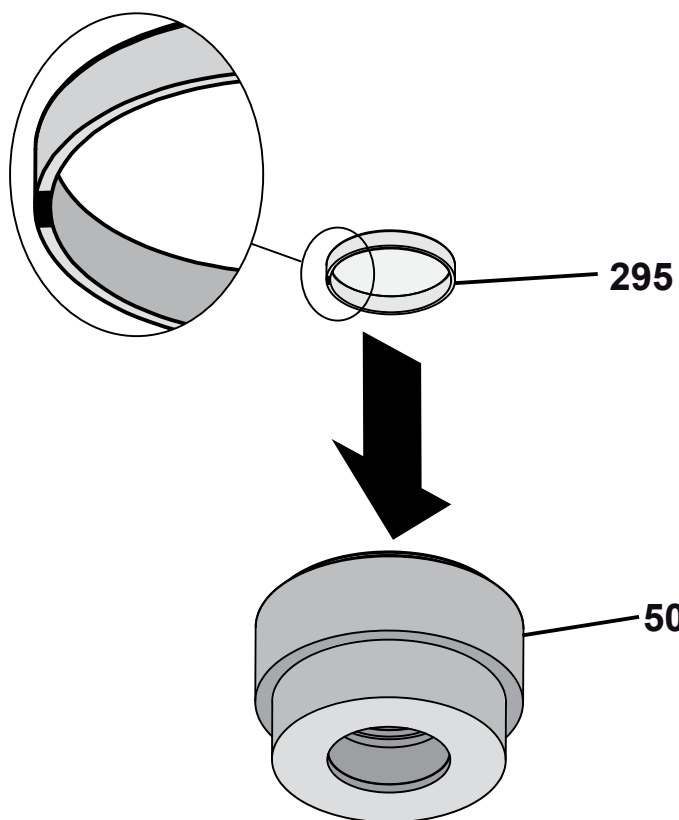

9

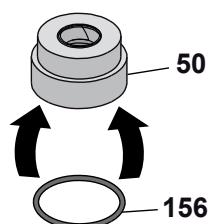

10

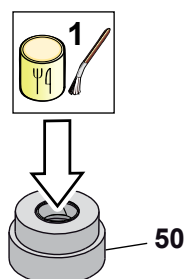

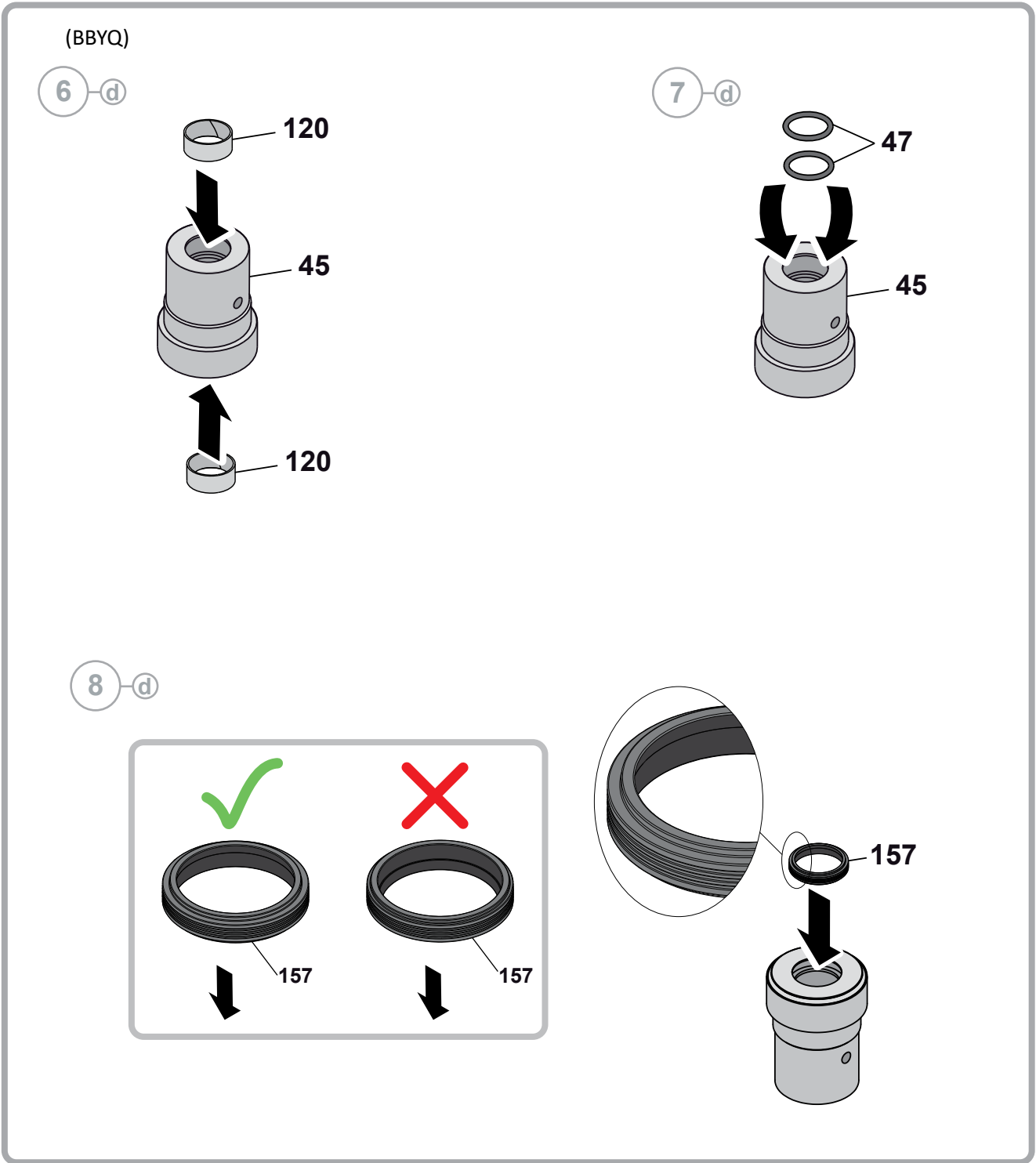

(BBYQ)

9-d

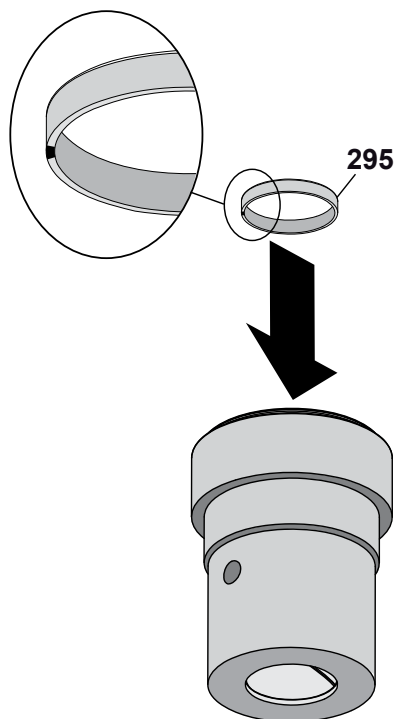

10-d

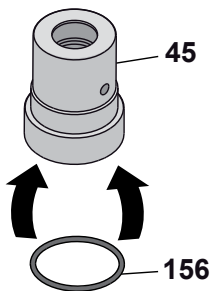

11-d

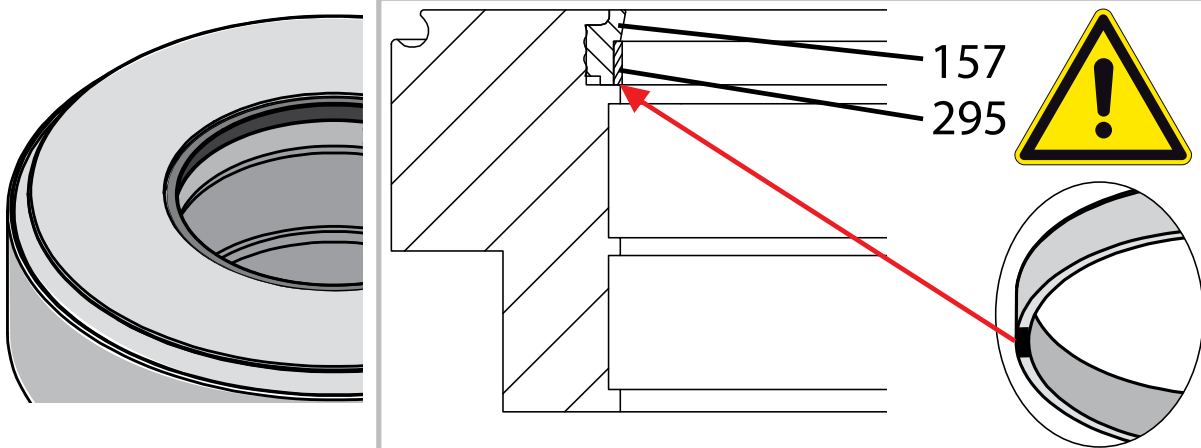
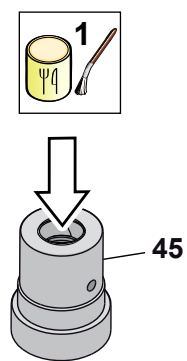

(BBYQ Special execution)

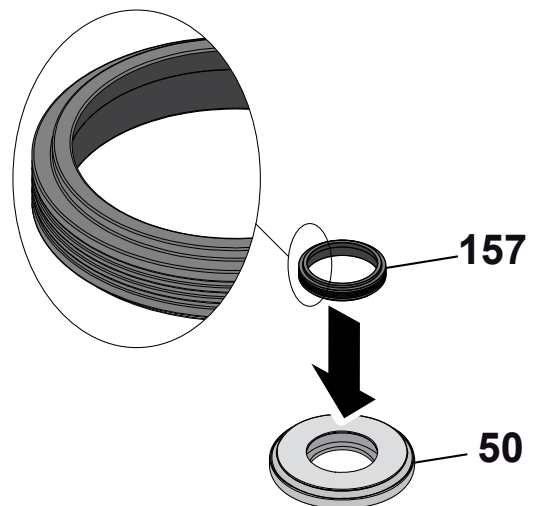
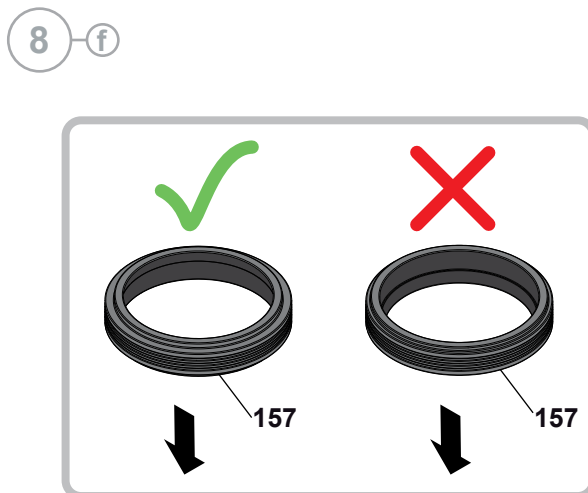
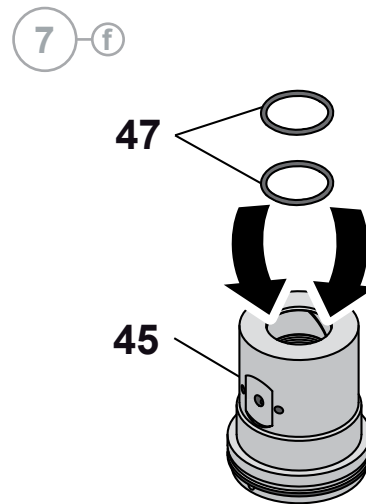
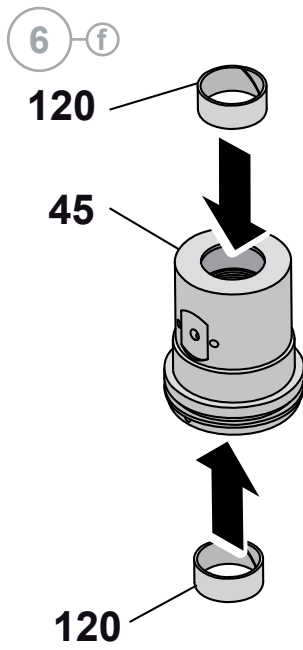

(BBYQ Special execution)

9-f

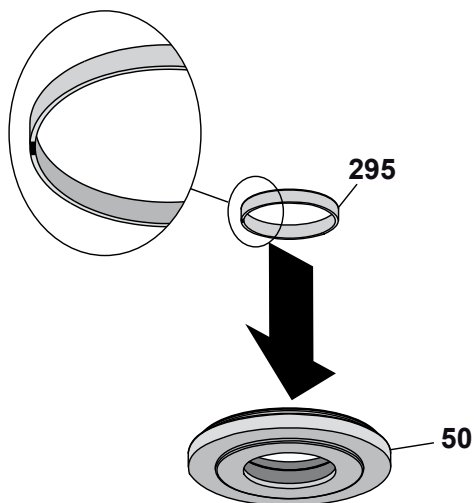

10-f

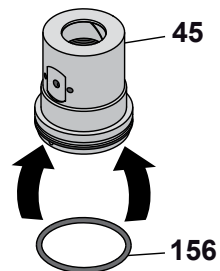

11-f

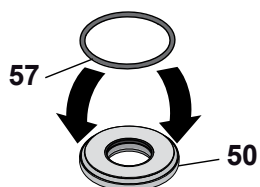

12-f

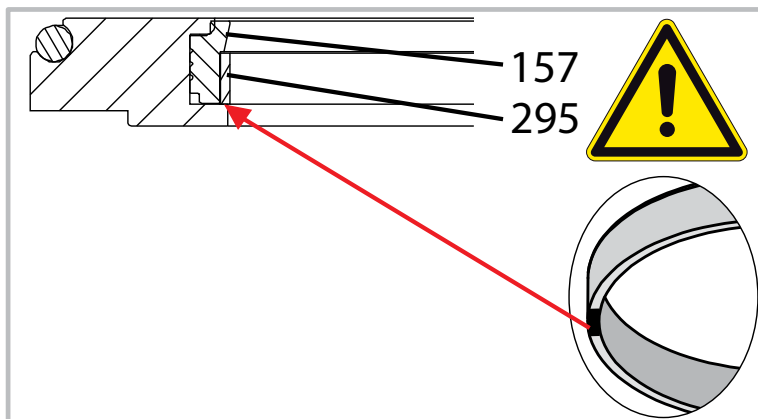
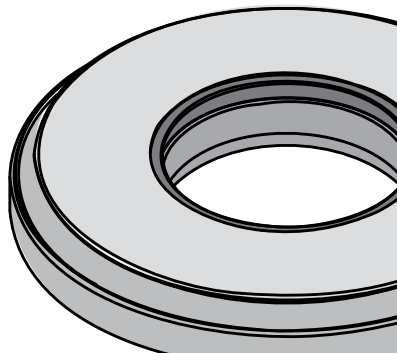
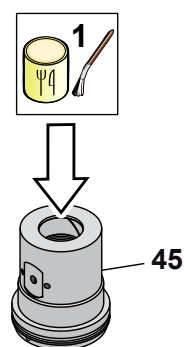

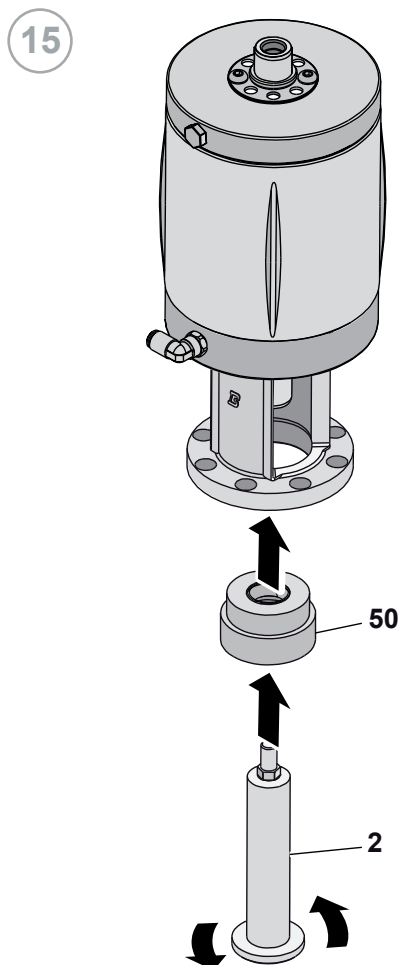
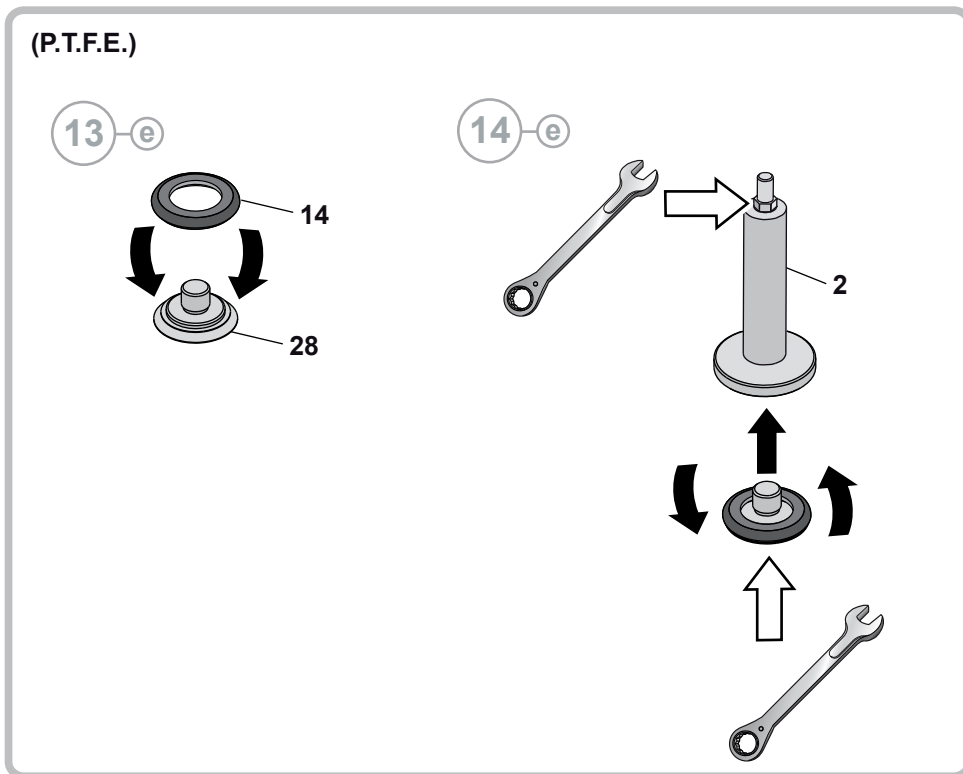

(BBYQ)

15-d

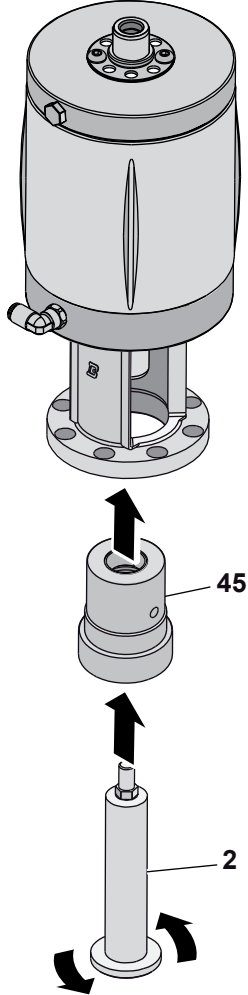

(BBYQ Special execution)

15-f

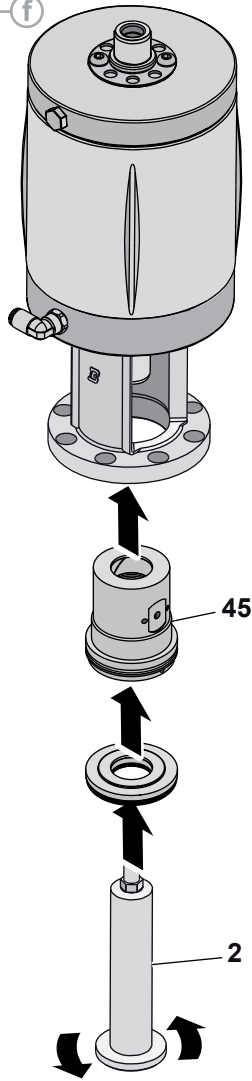

16-f

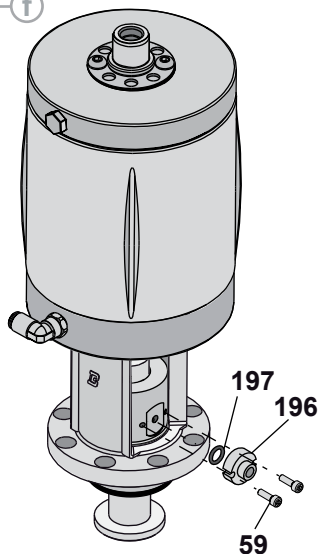

17

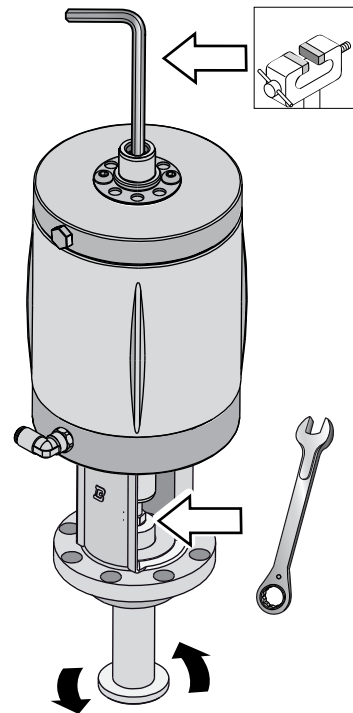

(Normally closed)

18-a

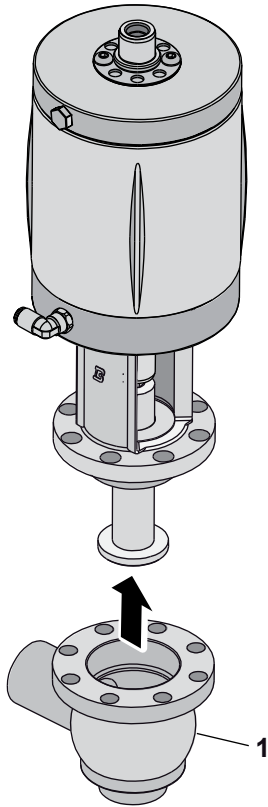

19-a

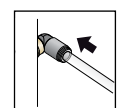

1

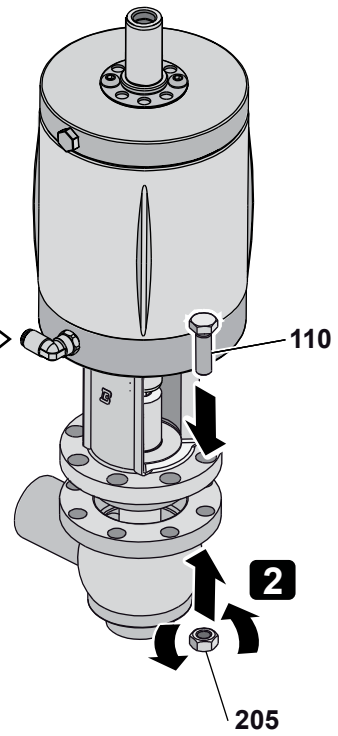

205

20-a

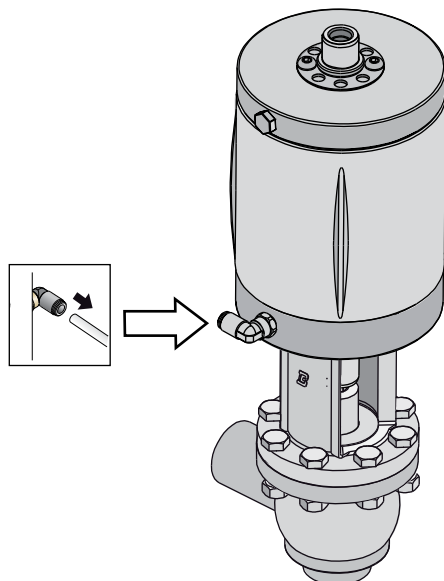

(Normally open or double acting)

18-b

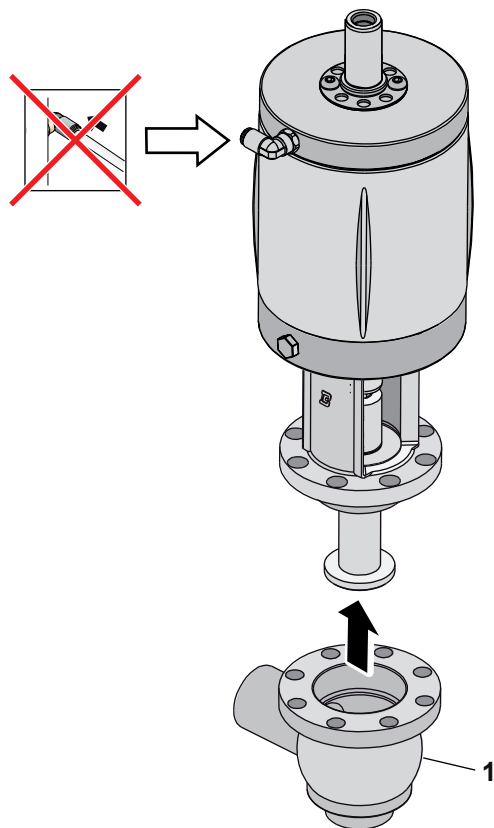

(M8)

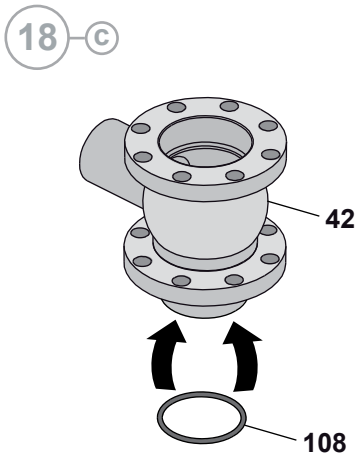

(Normally closed)

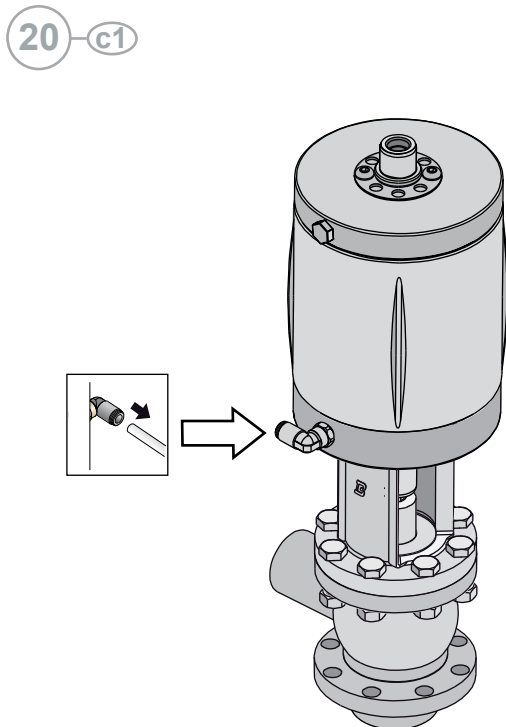
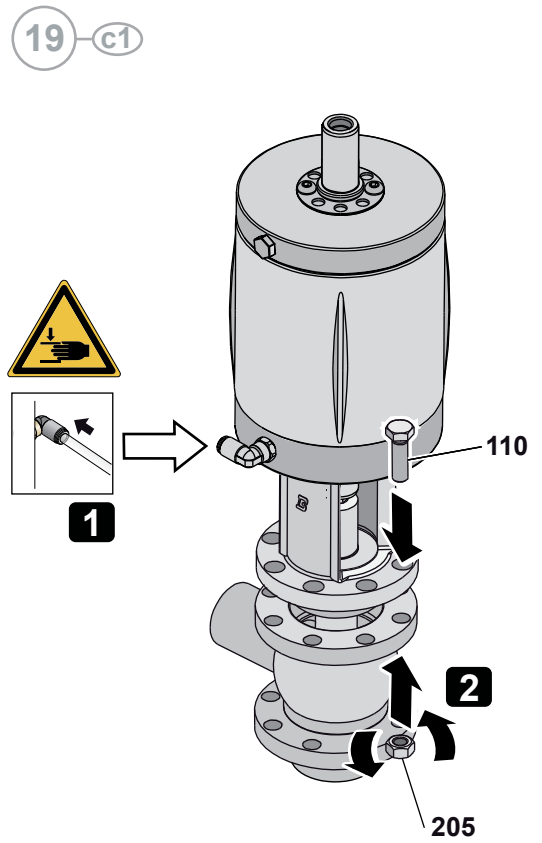

(Normally open or double acting)

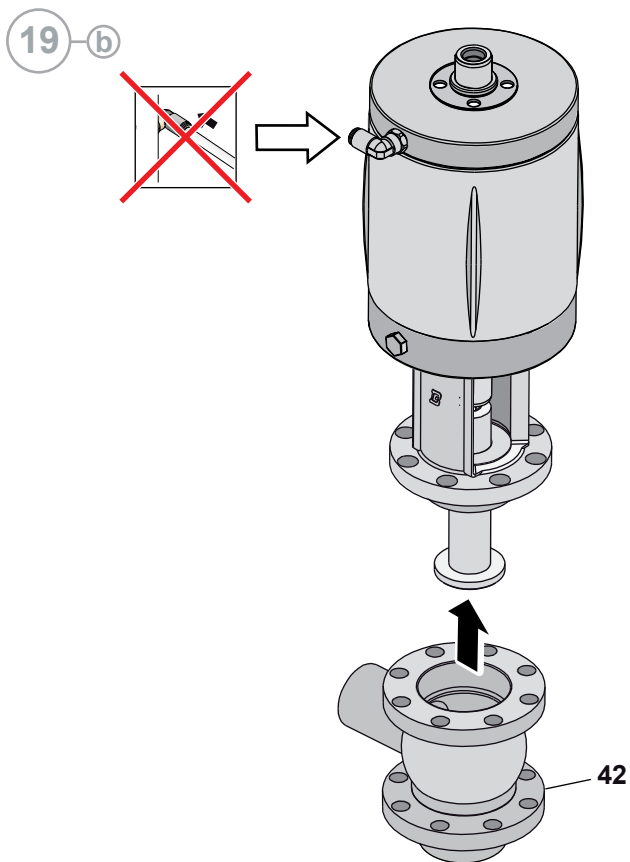

21-a

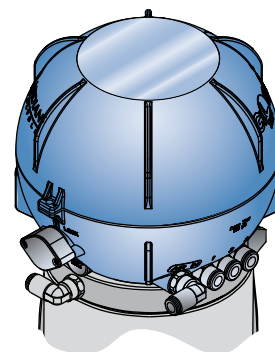
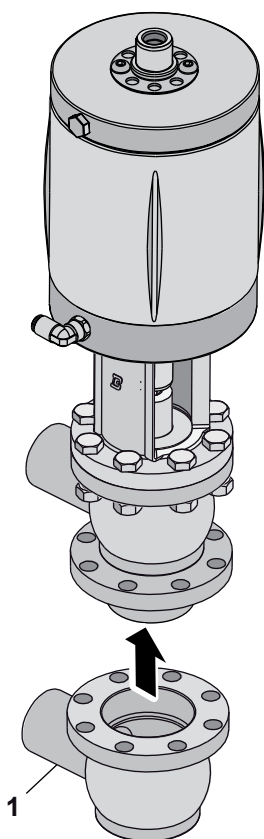

[M GIOTTO]

10.7 Pneumatic Valve BBZQ - BBYQ cylinder 108-156 Diverter

NO.	DESCRIPTION
1	Lower body
9	Cylinder
10	Bush
14	Sealing ring
17	Bush
23	Pin
24	Air connector
28	Shutter nut
30	Double shutter
33	Clamp
34	Screw
35	Assembly
40	Cap
42	Upper body
50	Gasket holder disc
57	Sealing ring
59	Screw
77	Diaphragm nut
108	Sealing ring
120	Bush
128	Diaphragm
154	Spacer
156	Sealing ring
157	Sealing ring
196	Steam connetor
197	Sealing ring
212	Double shutter stem
274	Sealing ring
275	Sealing ring
276	Sealing ring
277	Sealing ring
286	Air connector
295	Bush

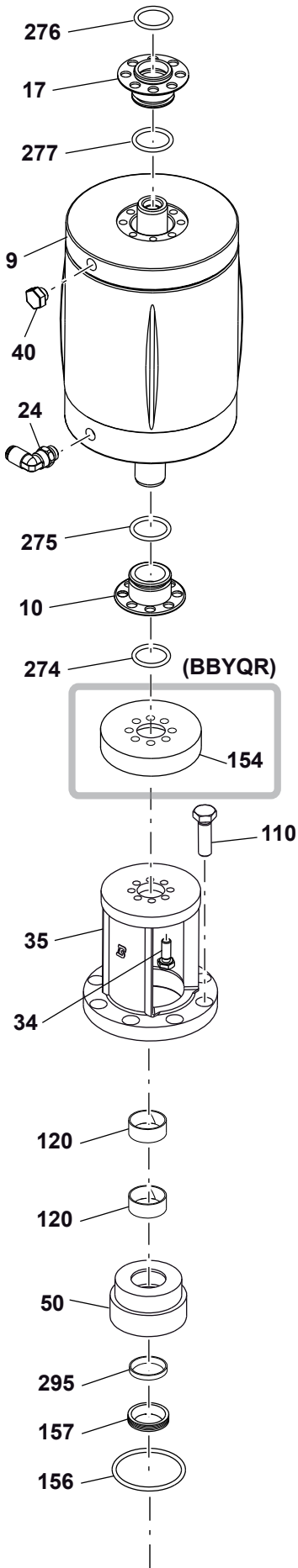

(BBYQ Special execution)

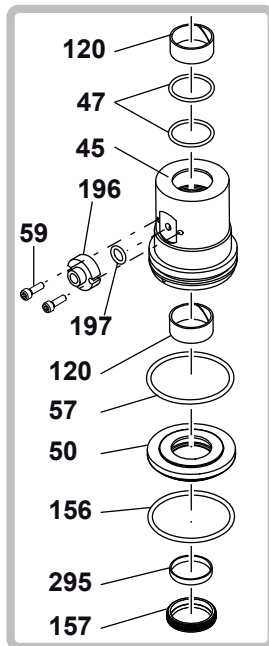

(BBYQ)

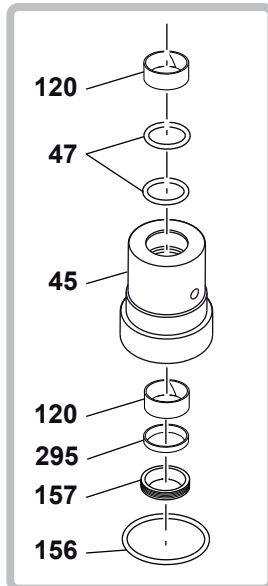

BBZP LL



BBZP M8-LLL



BBZP LL

(A)

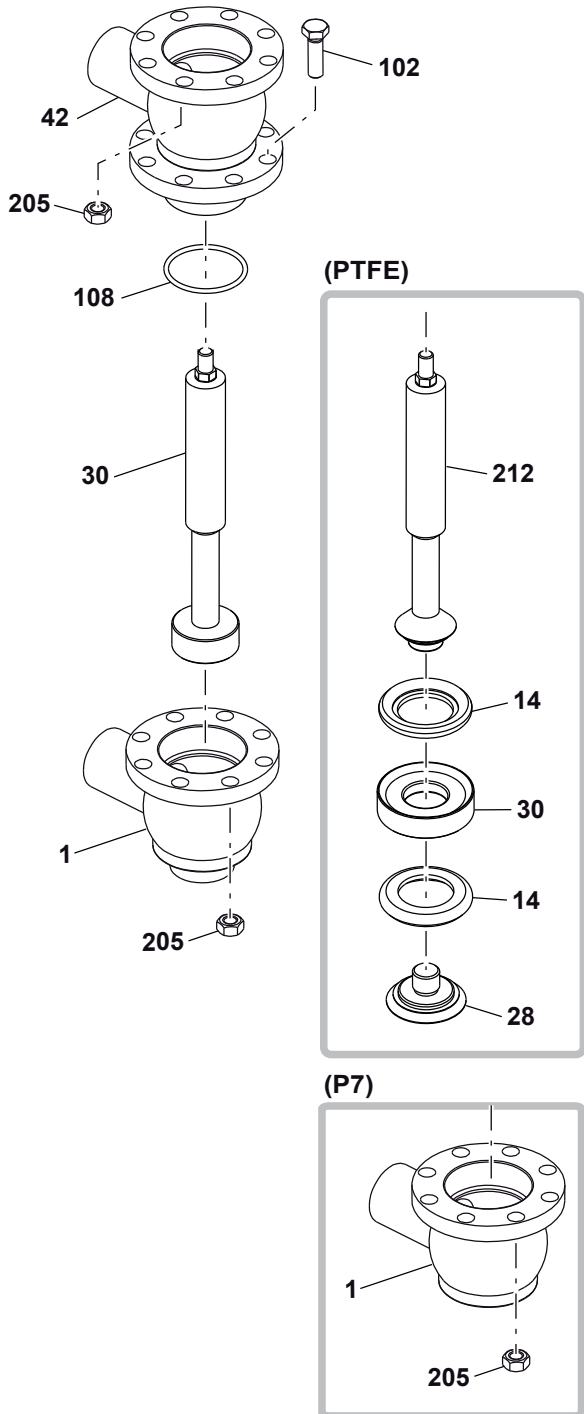

BBZP M8-LLL

(B)

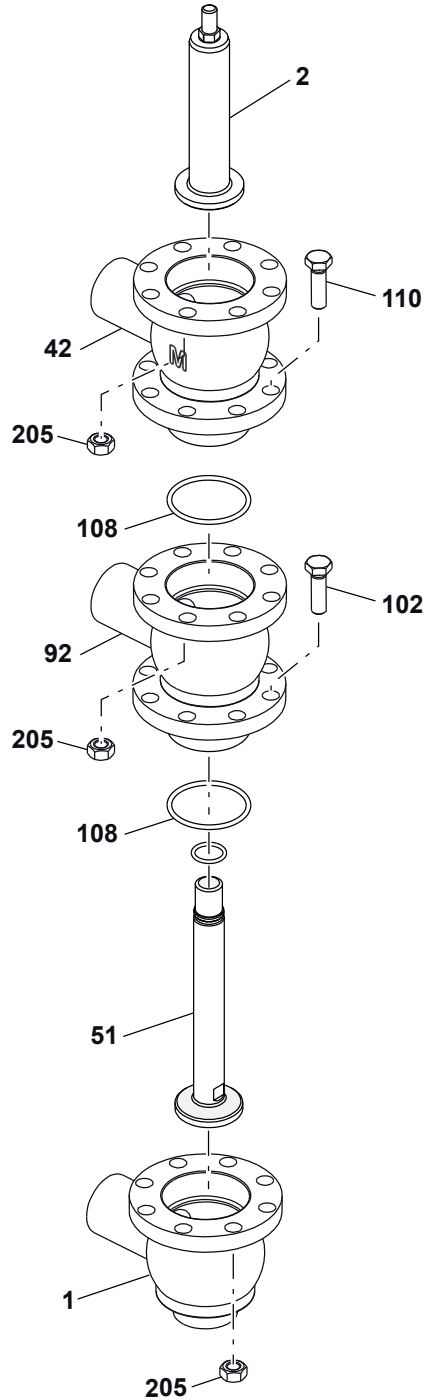

10.8 Disassembly of the BBZQ - BBYQ cylinder 108-156 Diverter

1

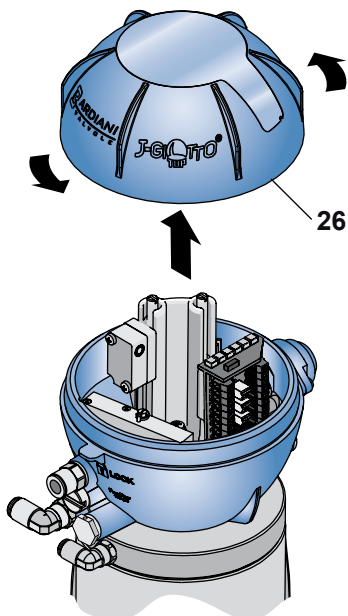

2

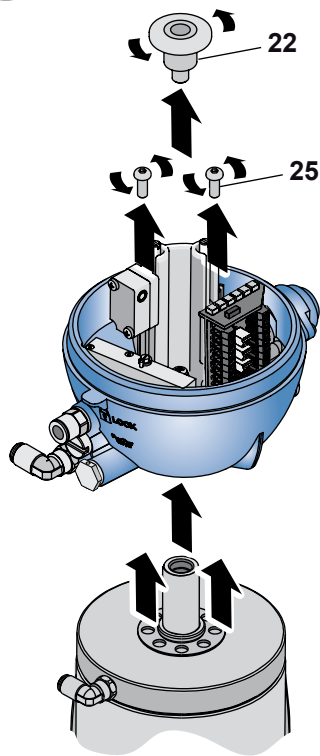

3

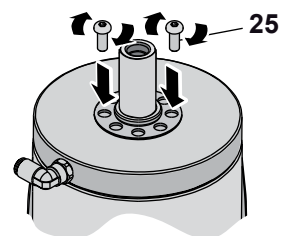

a

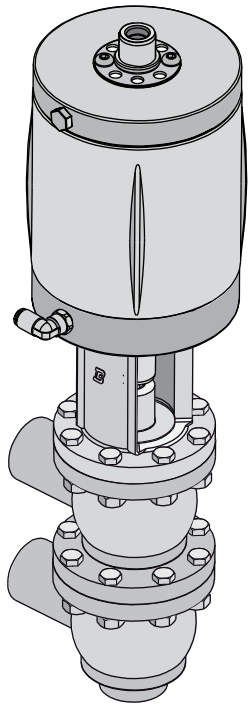

[A S BBZQ-LL-108-156]

b

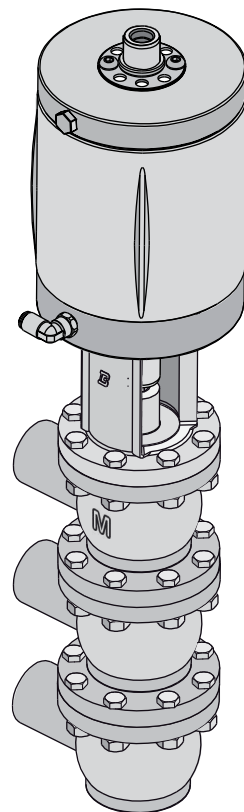

[B S BBZQ-M8-LLL108-156]

A Disassembly Of The BBZQ - BBYQ LL - BBZQ P7 - BBYQ P7

(Normally closed)

1 a1

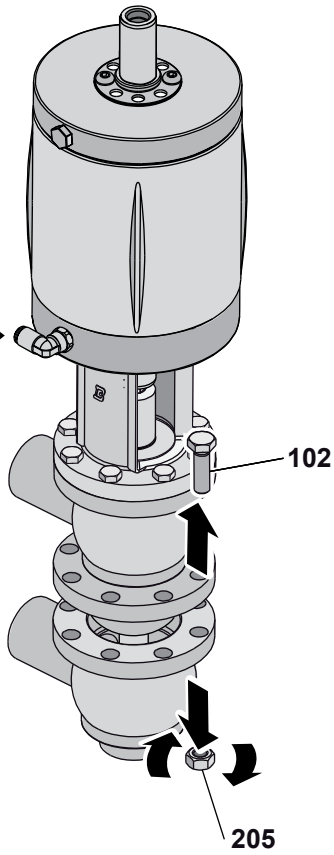
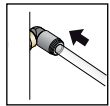

2 a1

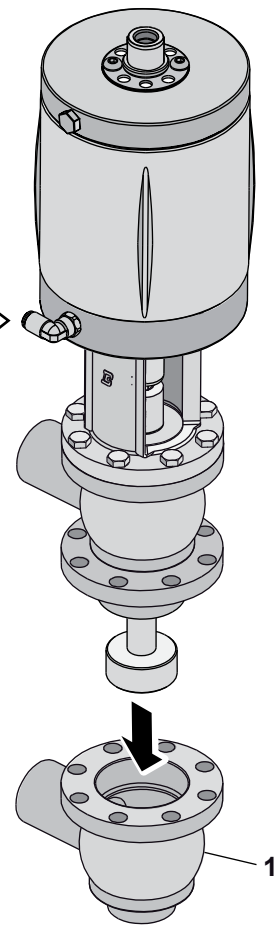
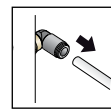

3 a1

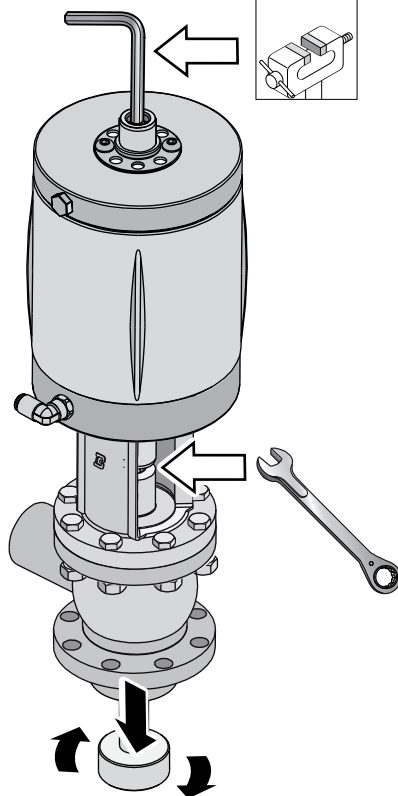
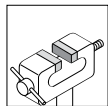

P7

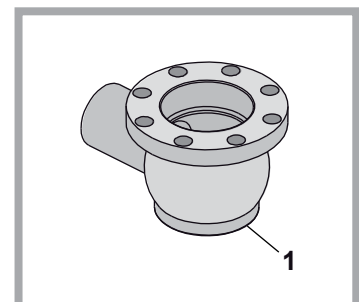

(Normally open or double acting)

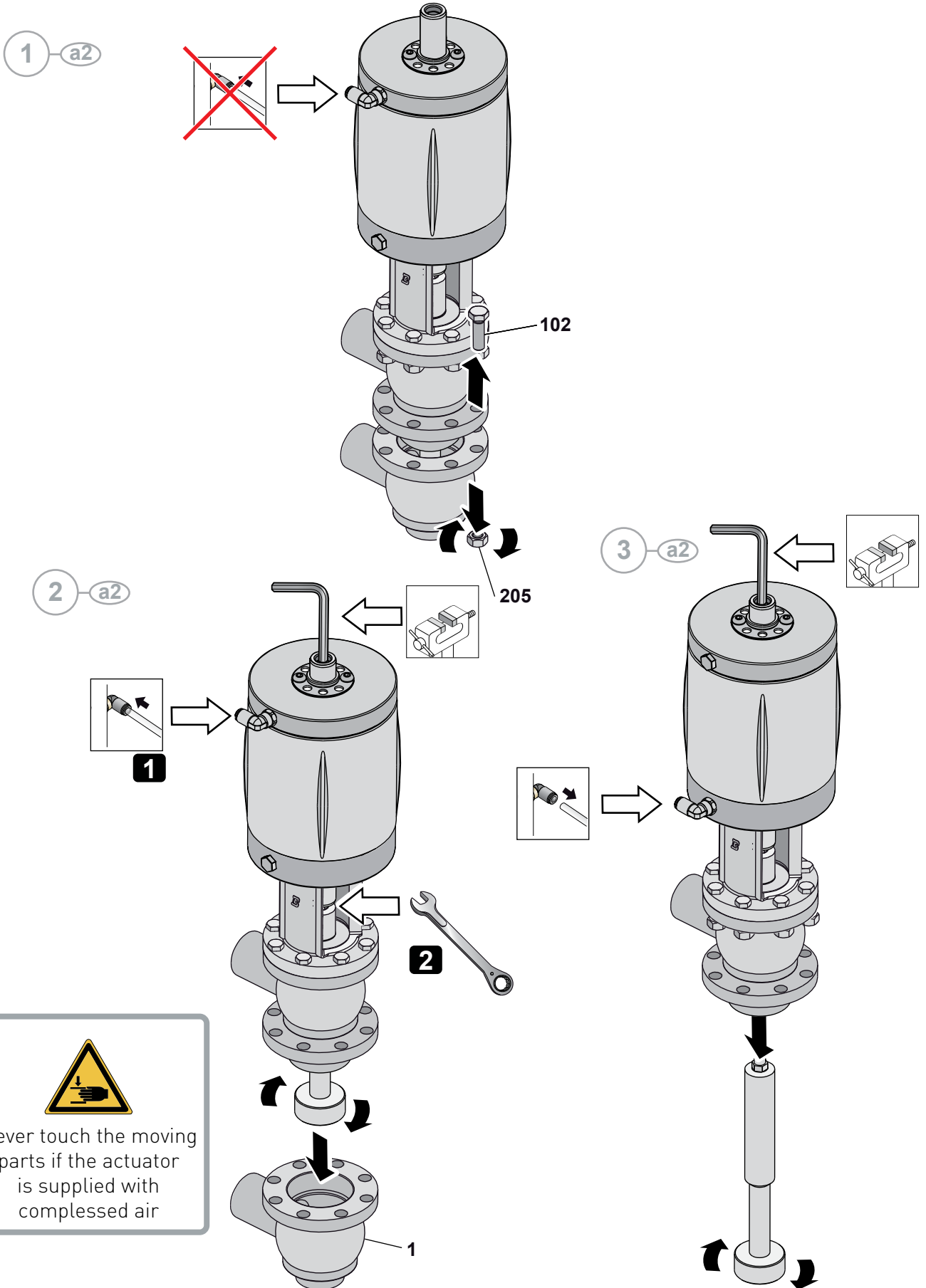

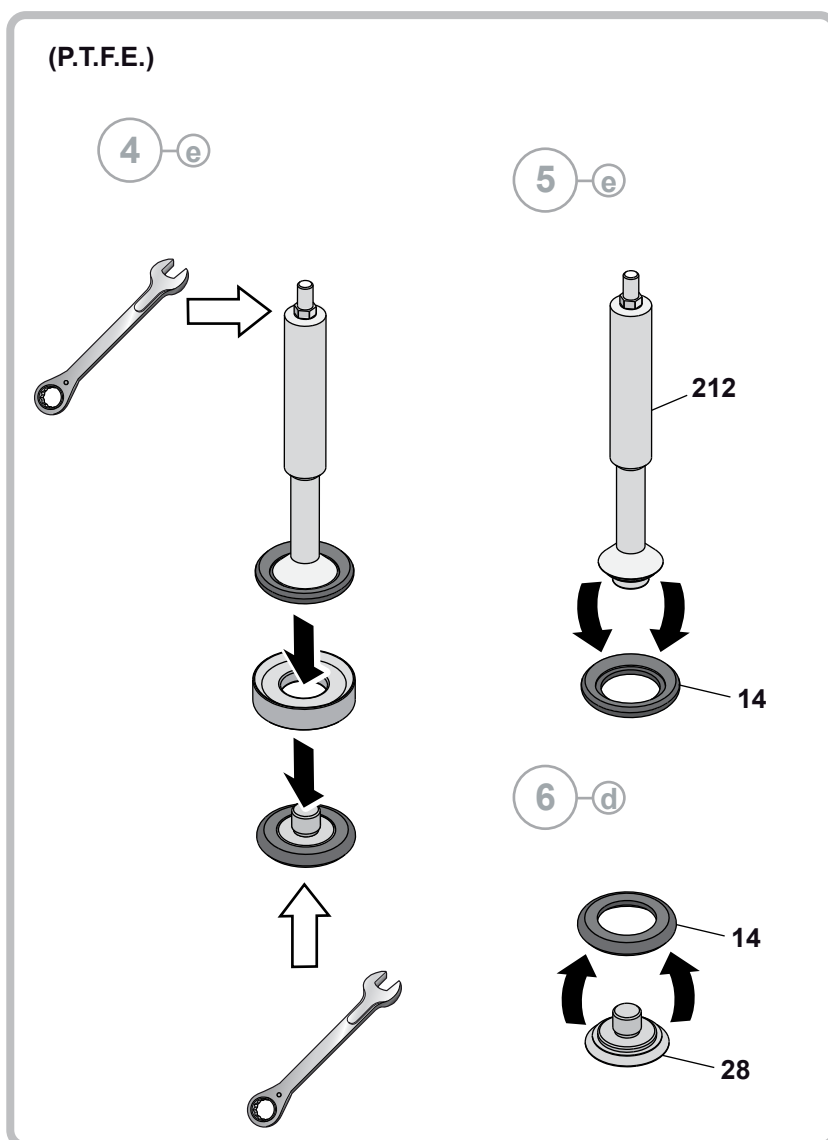

 Never touch the moving parts if the actuator is supplied with compressed air

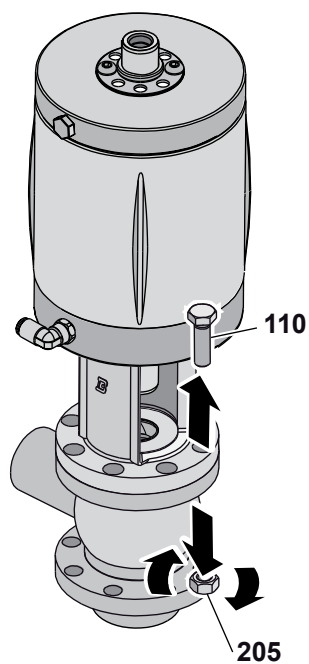

7-a

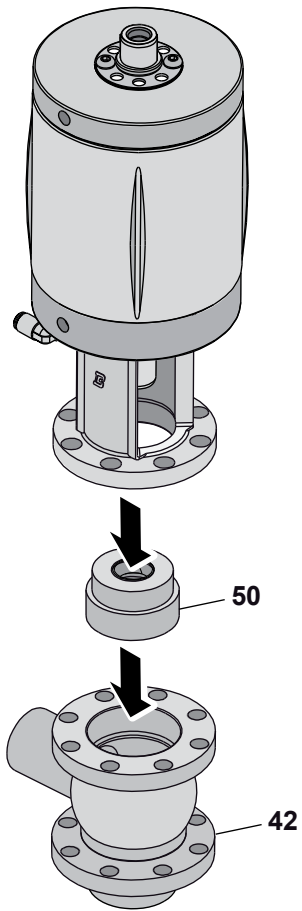

8 a



(BBYQ)

8 d

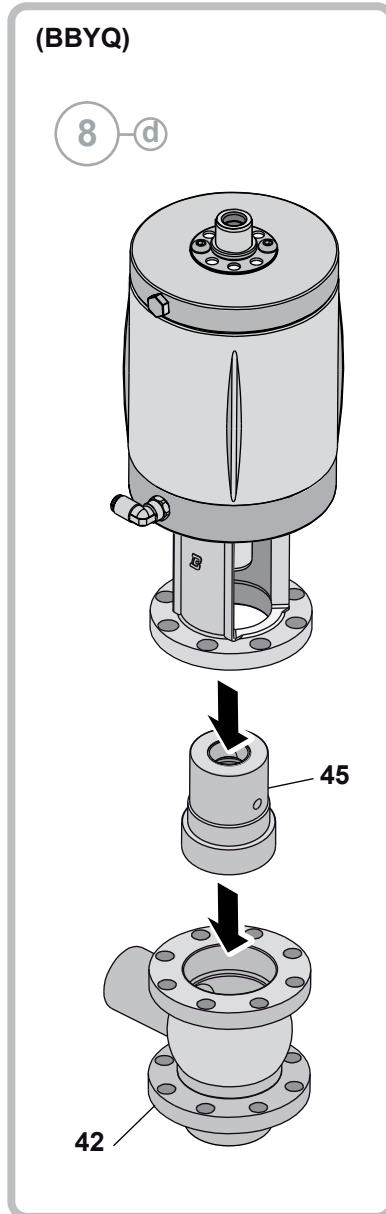

(BBYQ Special execution)

8 f

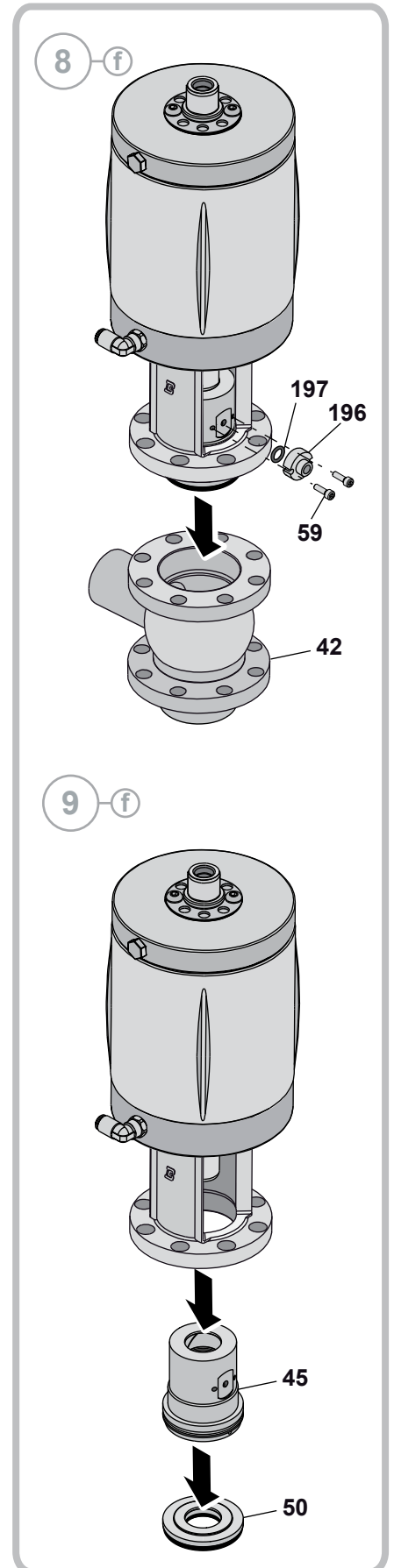

9 f

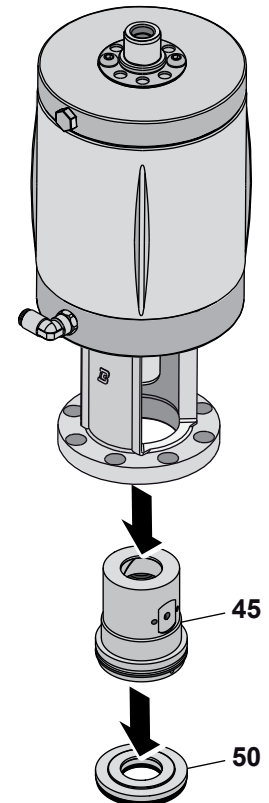

10-a

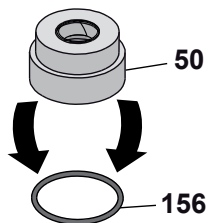

11-a

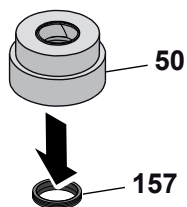

12-a

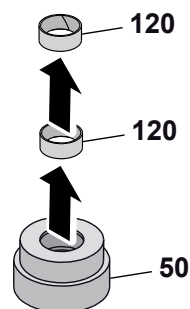

(BBYQ)

10-d

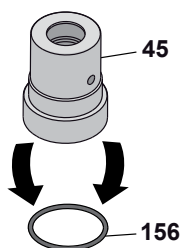

11-d

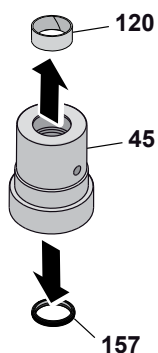

12-d

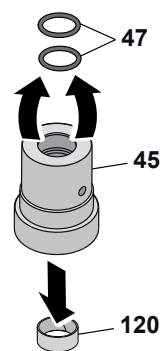

(BBYQ Special execution)

10-f

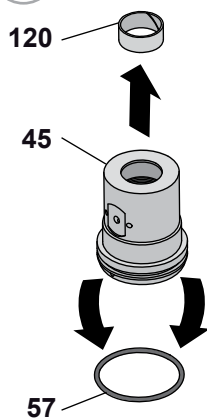

11-f

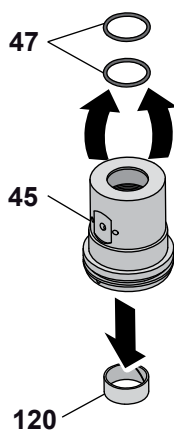

12-f

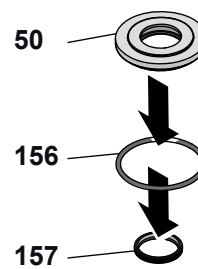

13-a

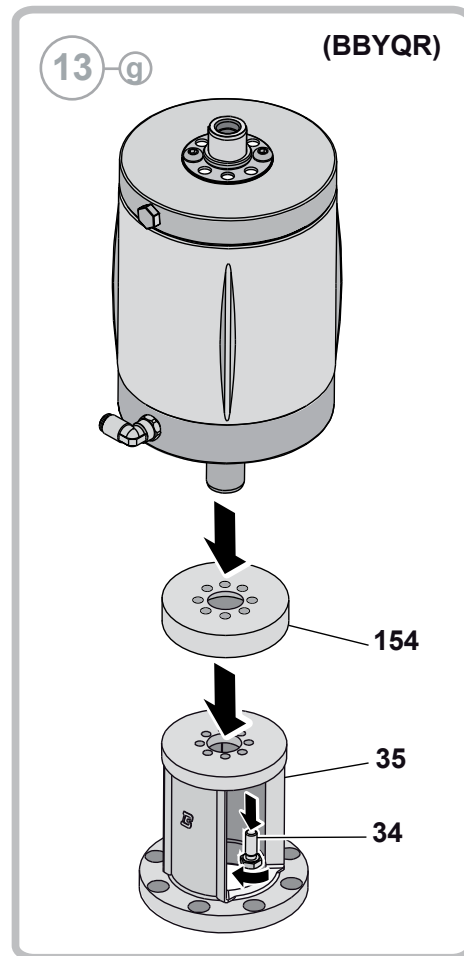
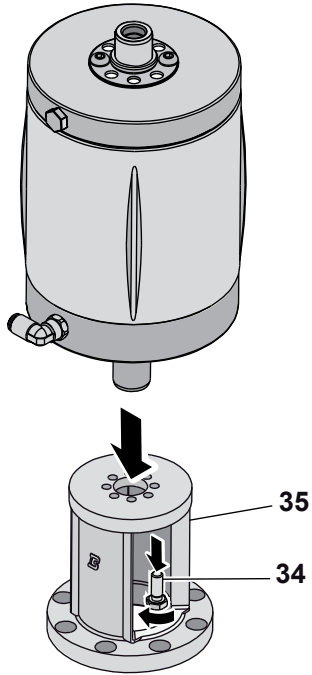

14-a

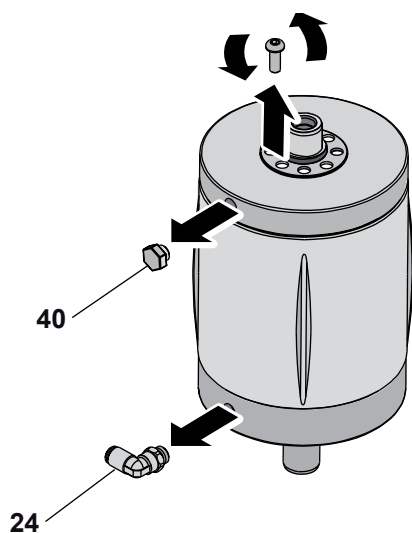

15-a

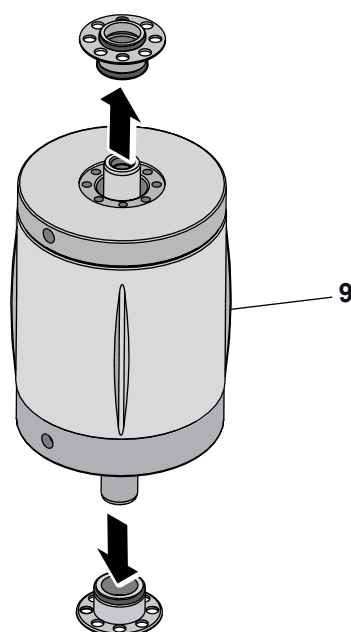

16

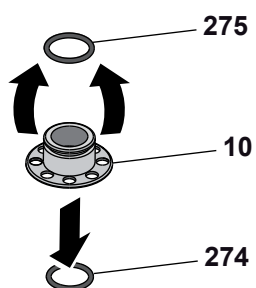

17

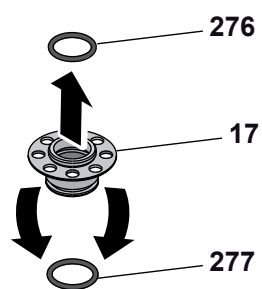

[M D BBZQ-108-156]

B Disassembly Of The BBZQ M8-LLL

(Normally closed)

1 b1

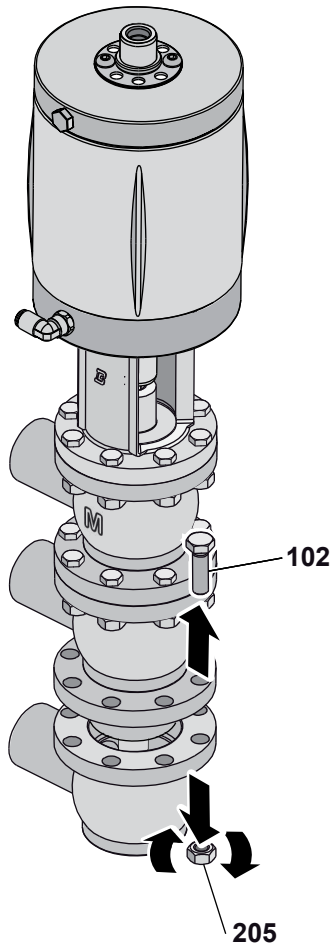

2 b1

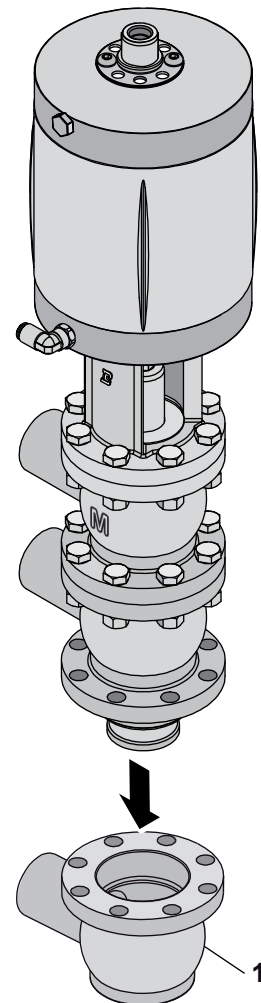

3 b1

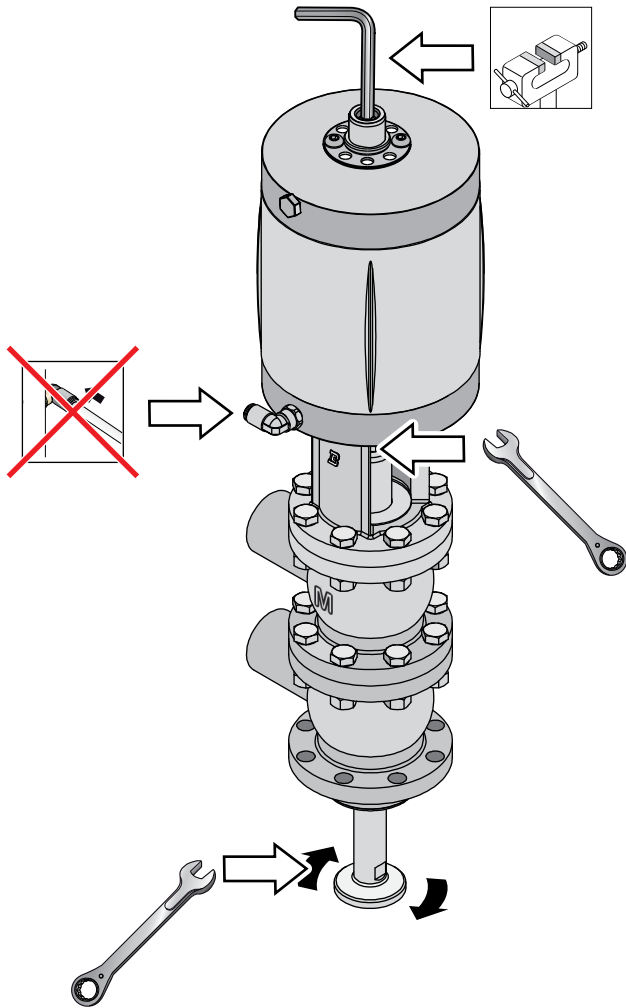

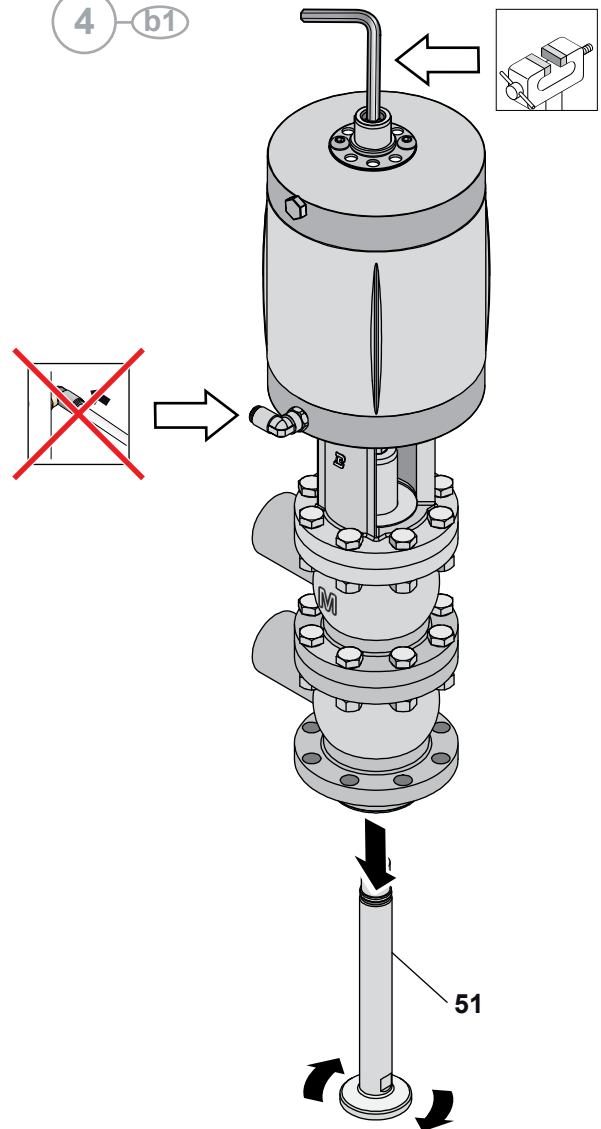

4 b1

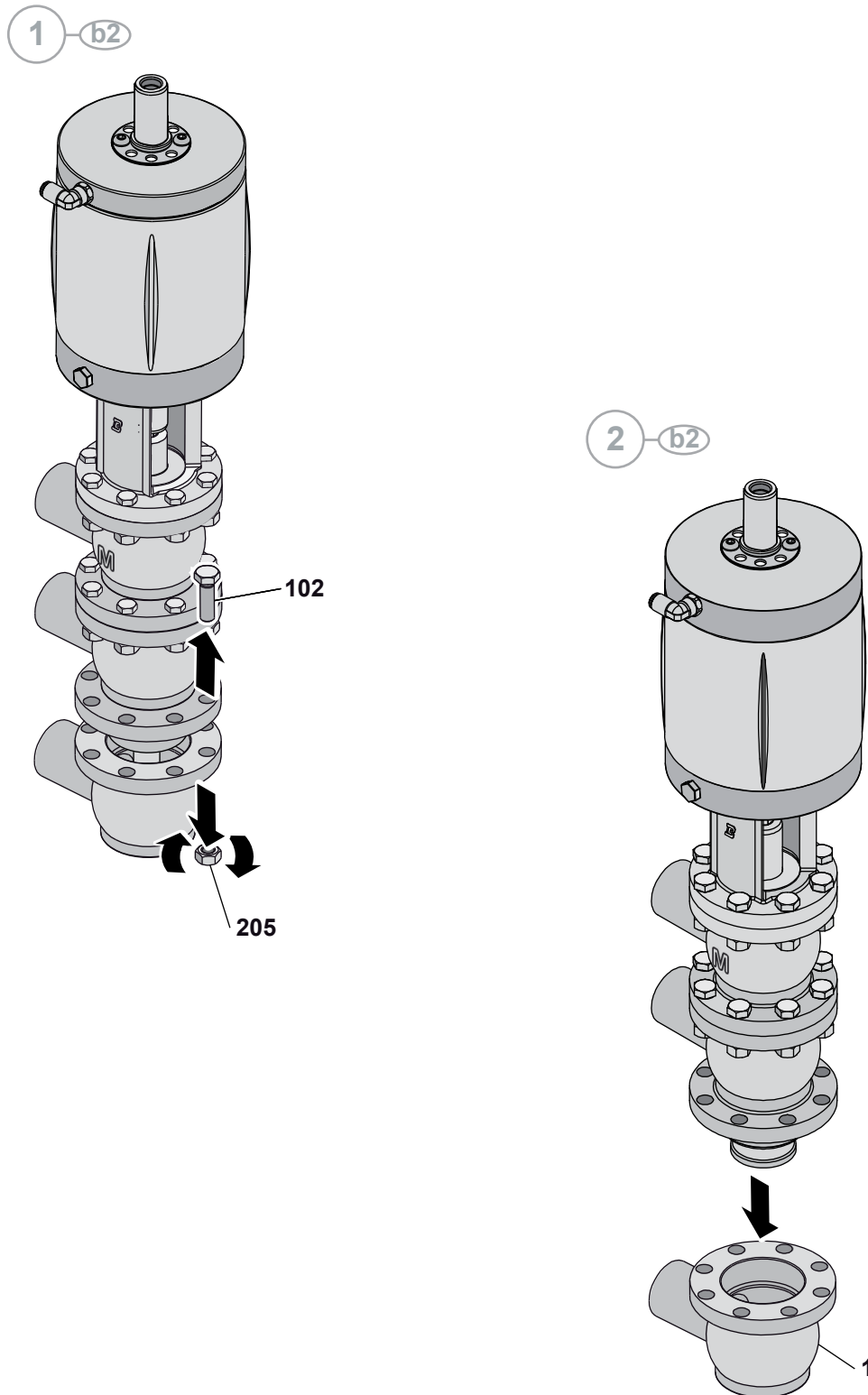

(Normally open or double acting)

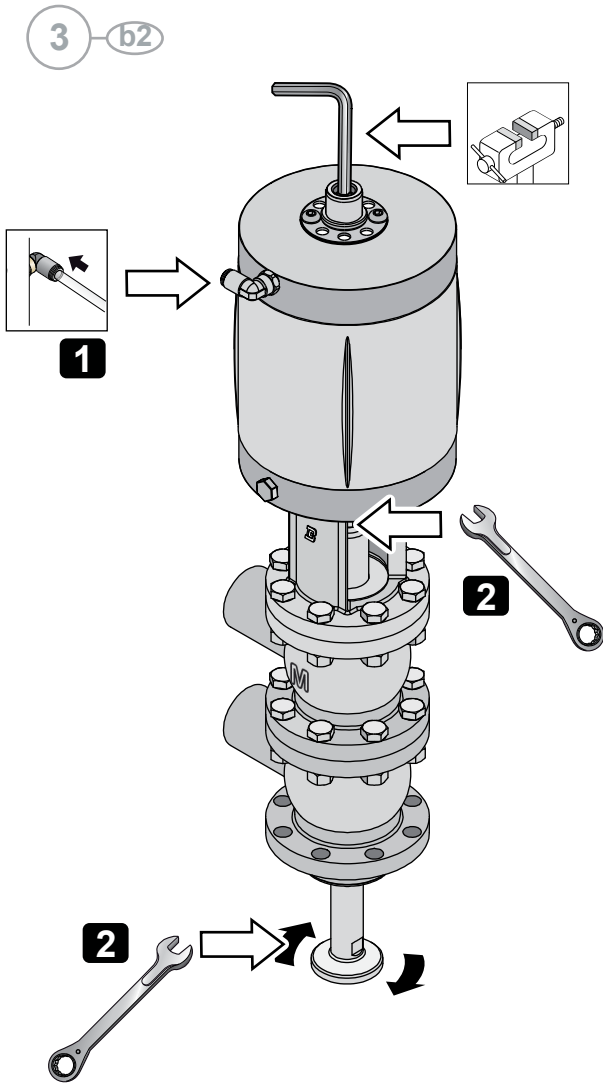



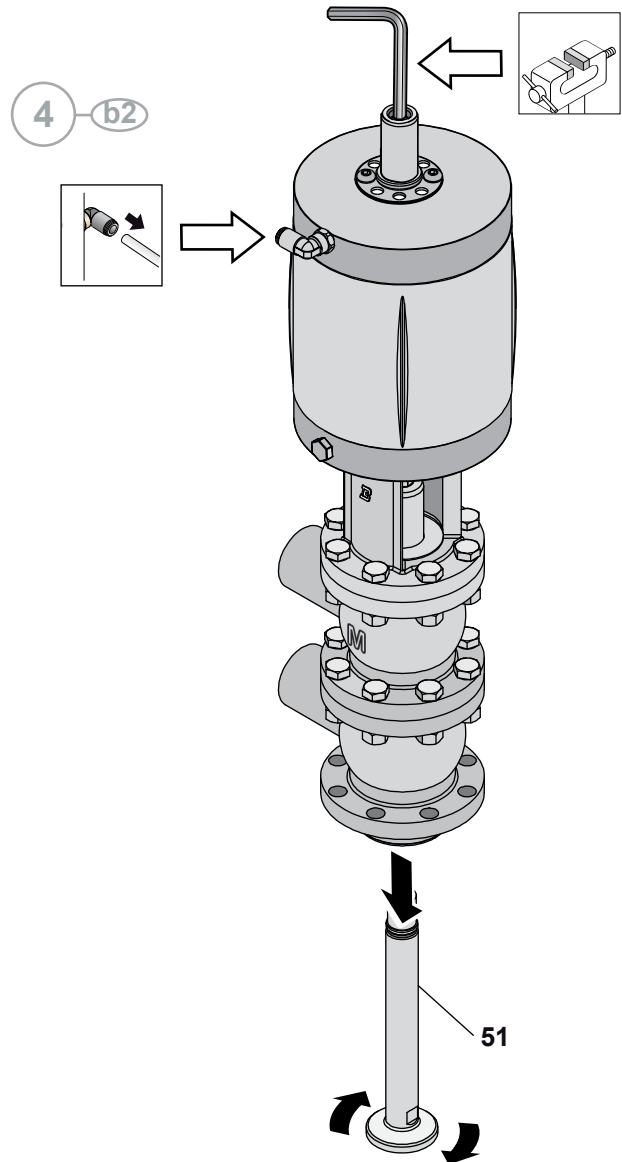

Never touch the moving parts if the actuator is supplied with compressed air

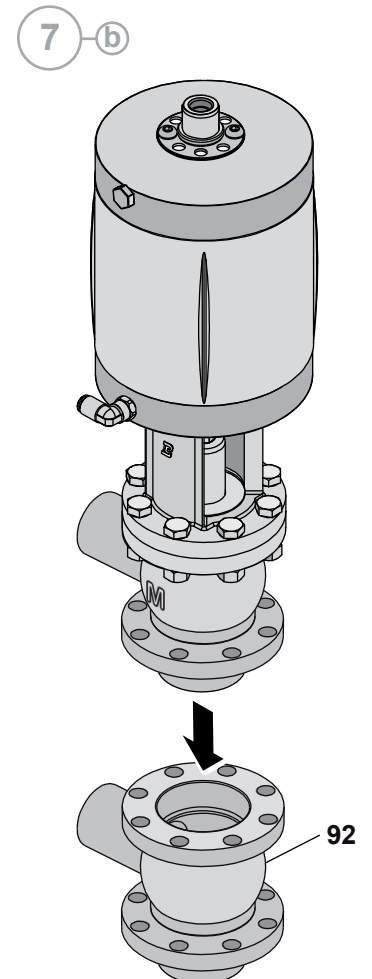
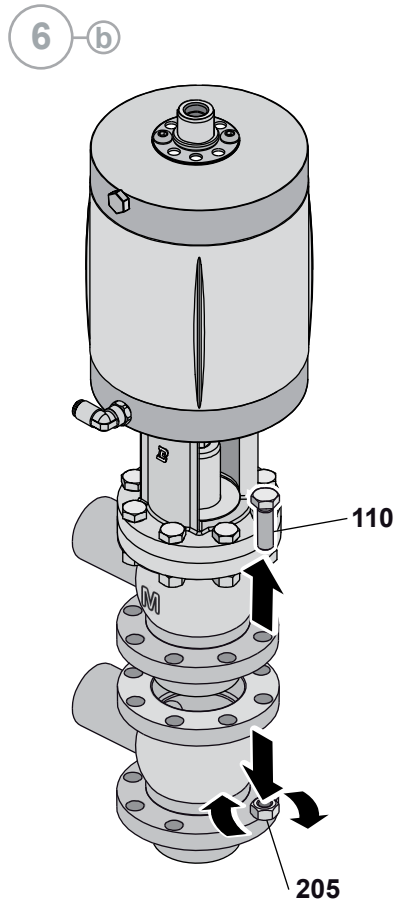
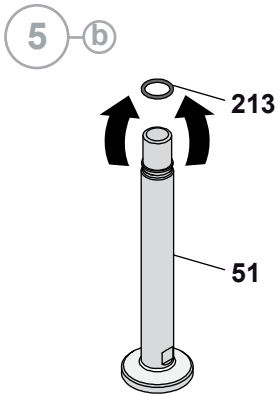

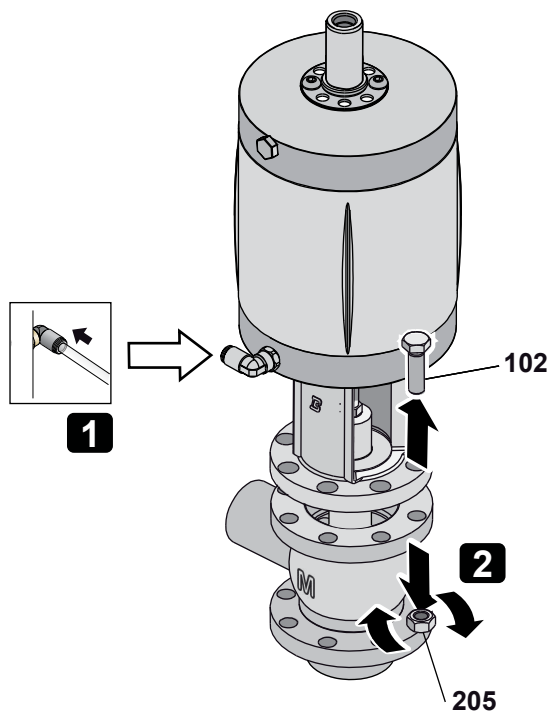

(Normally closed)

8 b1



Never touch the moving parts if the actuator is supplied with compressed air

9 b1

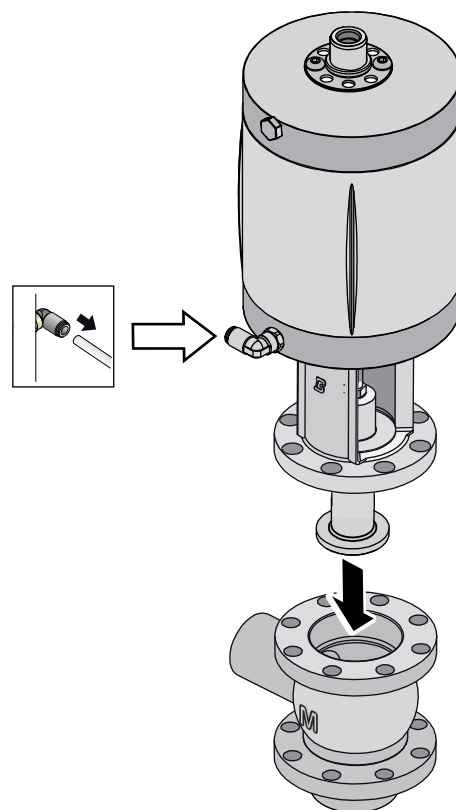

(Normally open or double acting)

8 b2

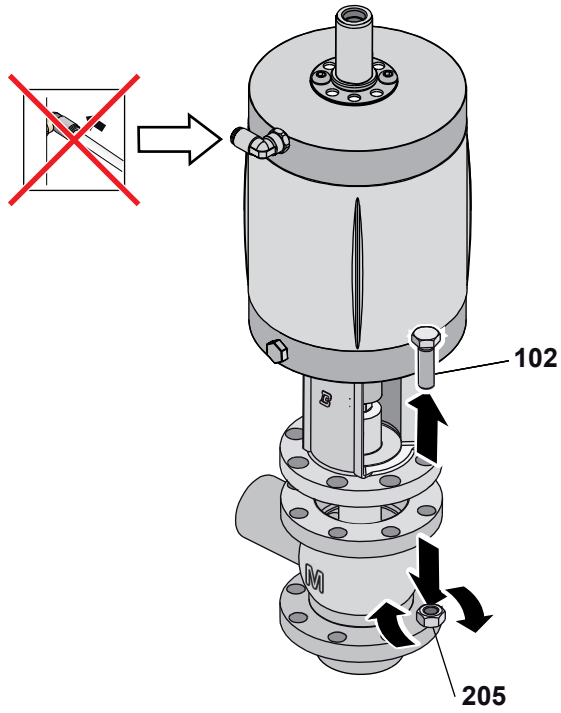

9 b2

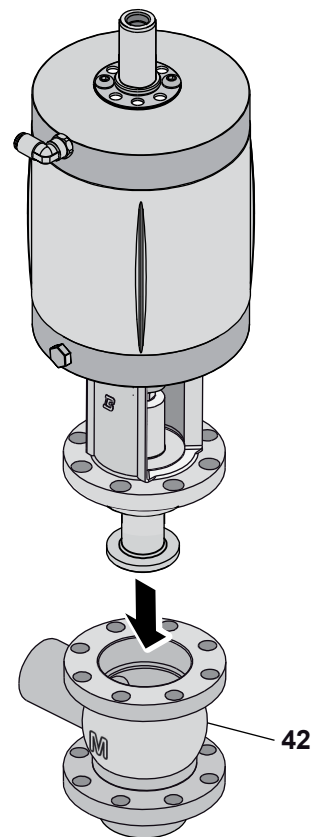

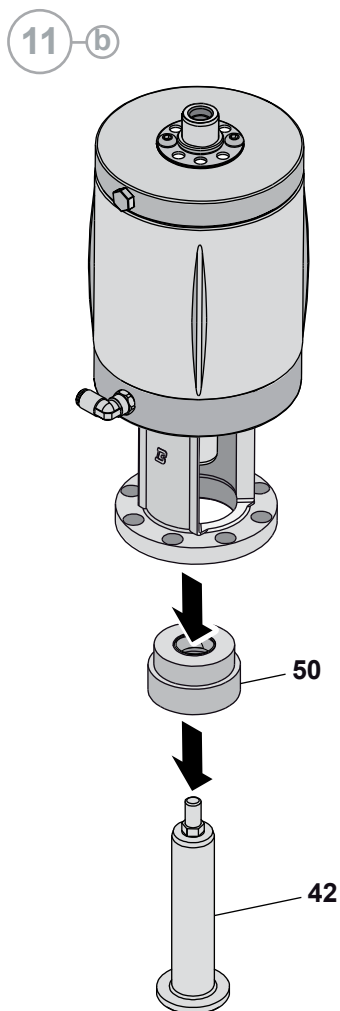
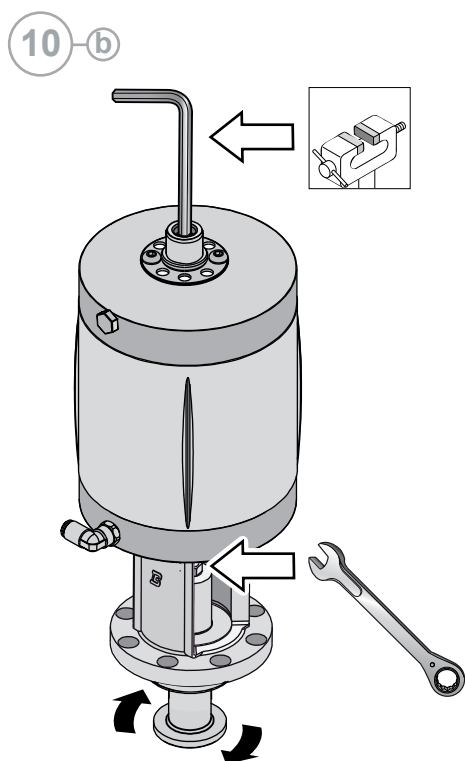

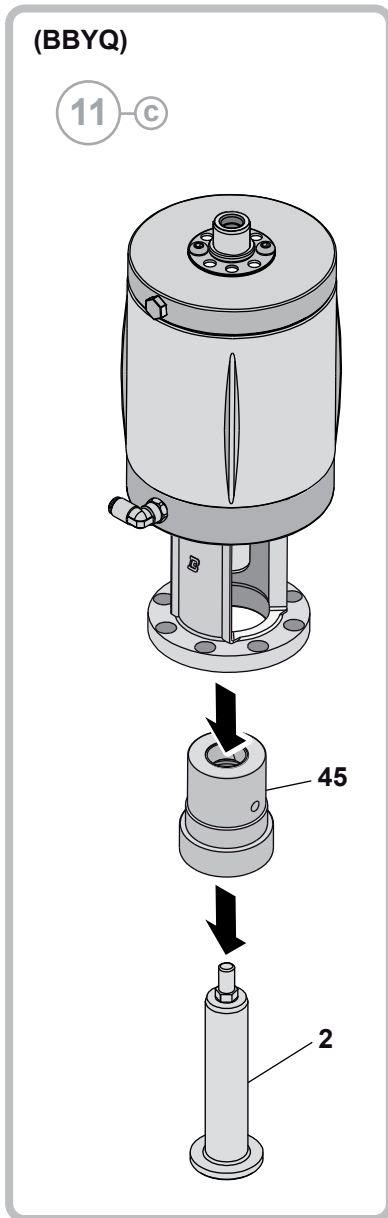

(BBYQ Special execution)

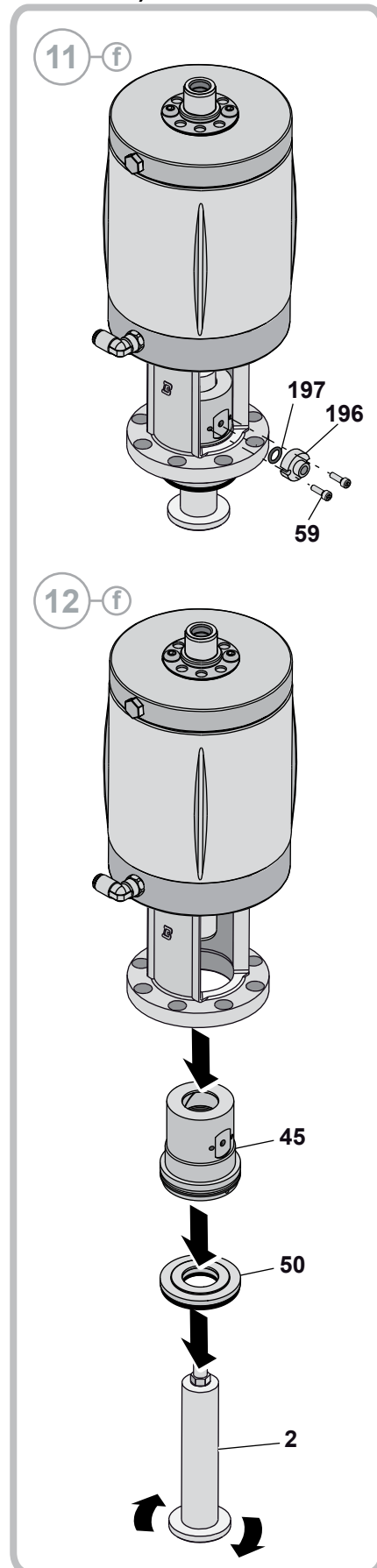

13-b

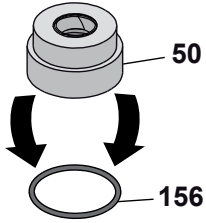

14-b

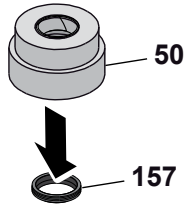

15-b

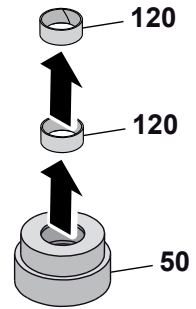

(BBYQ)

13-d

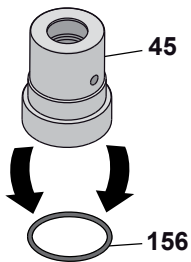

14-d

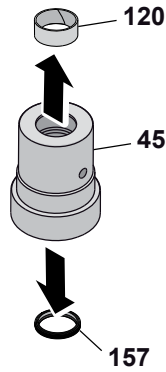

15-d

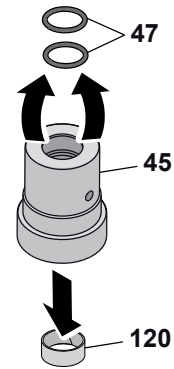

(BBYQ Special execution)

13-f

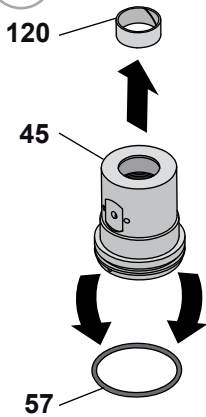

14-f

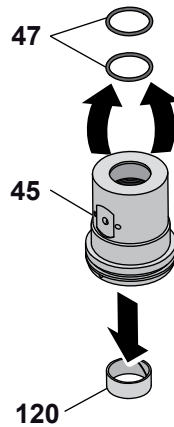

15-f

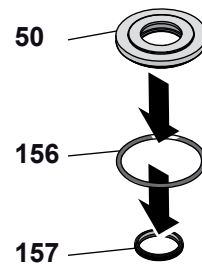

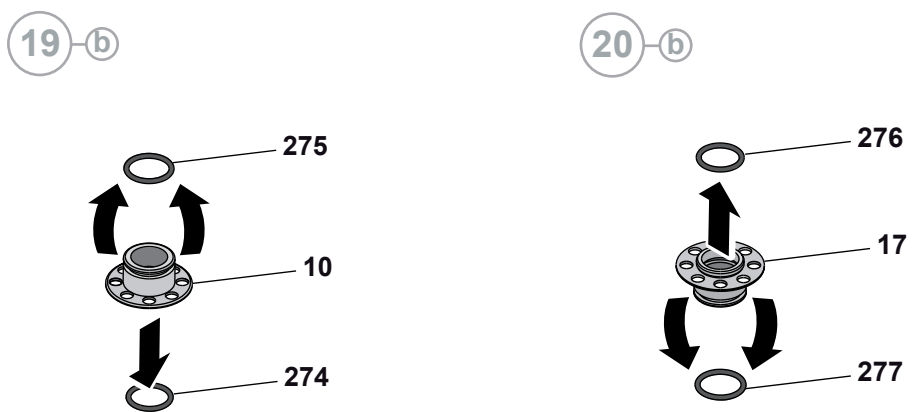
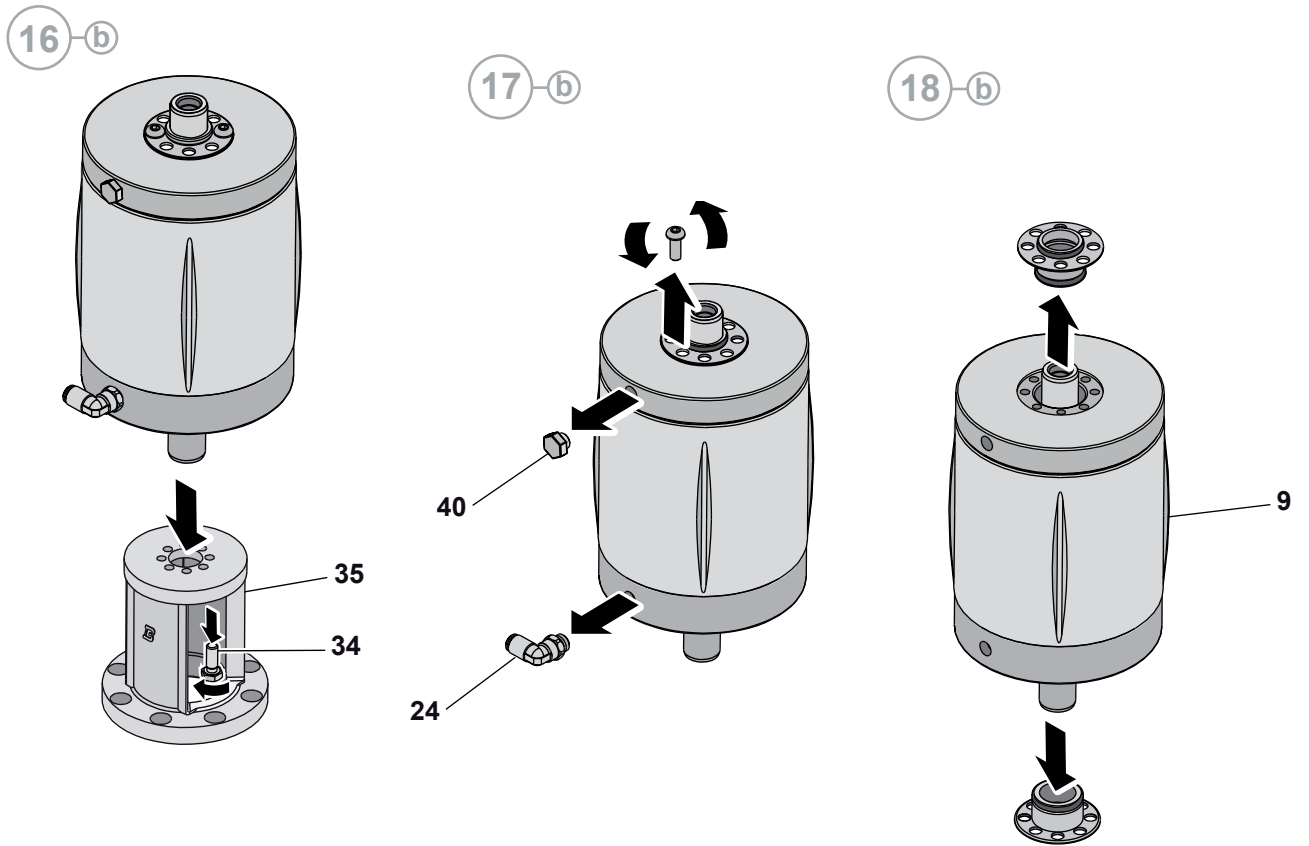

10.9 Assembly of the BBZQ - BBYQ cylinder 108-156 Diverter

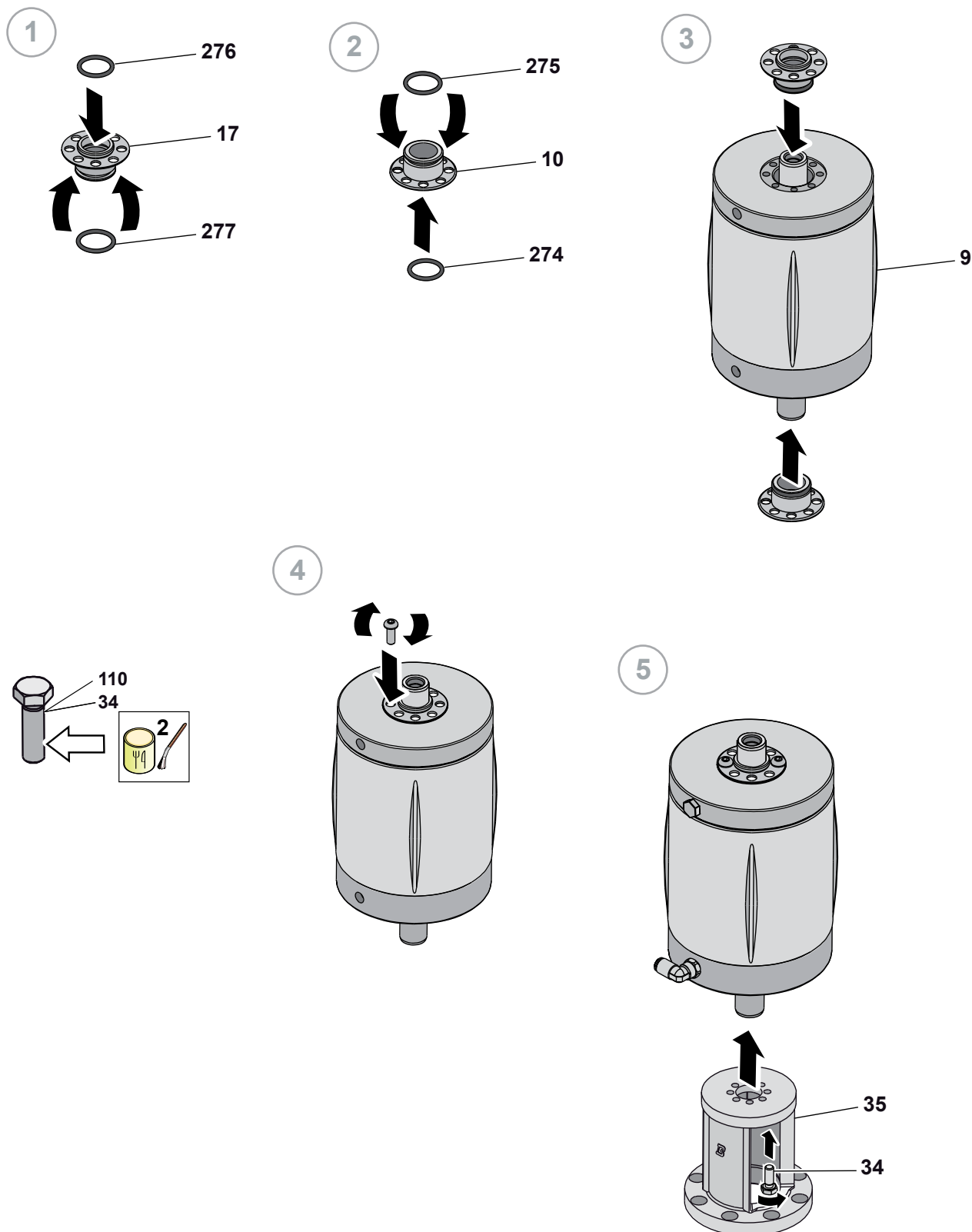

10.9.1 Select normally close or normally open cylinder

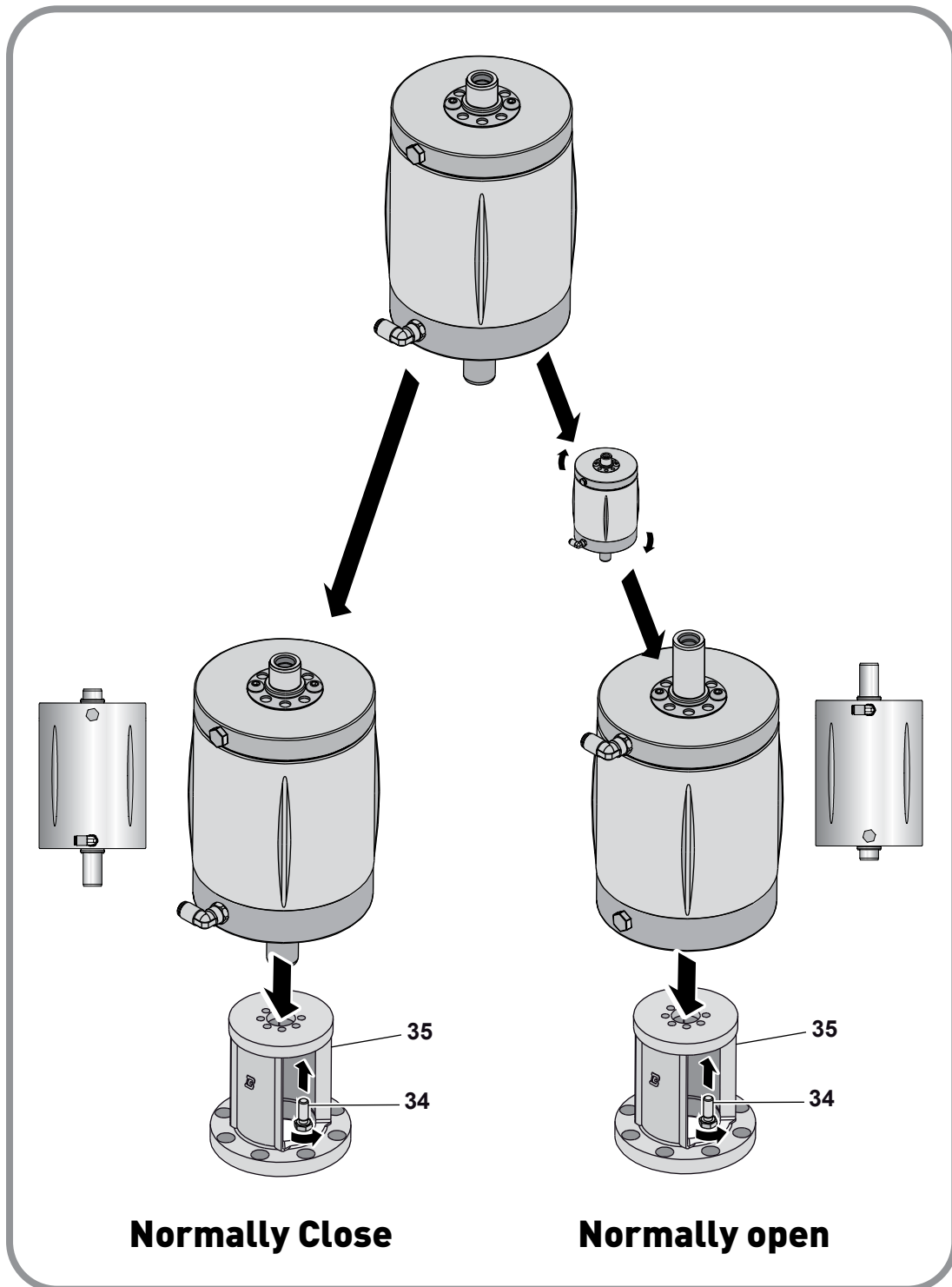

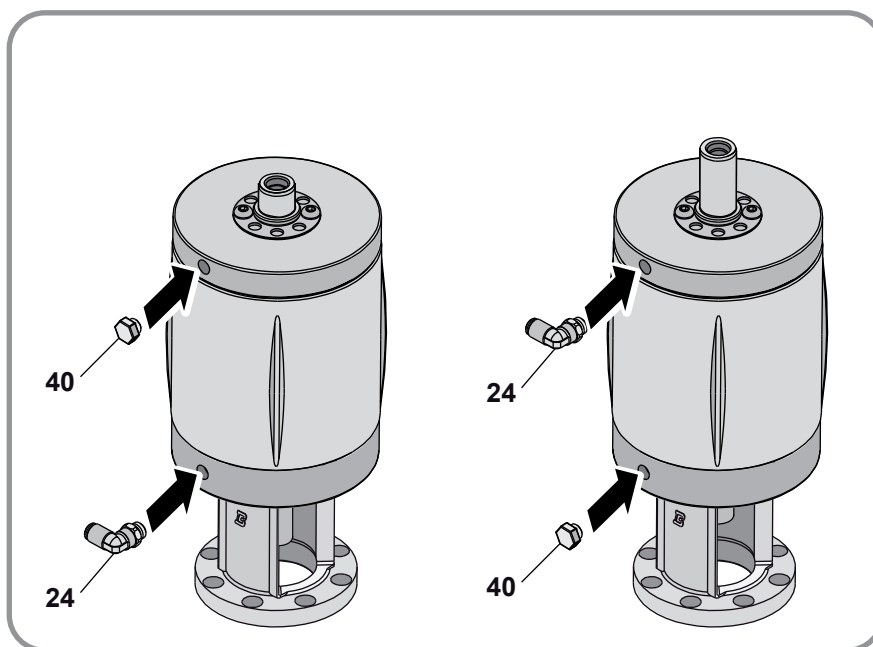

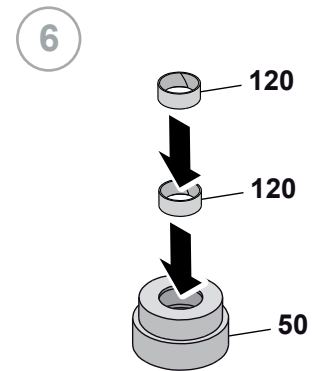
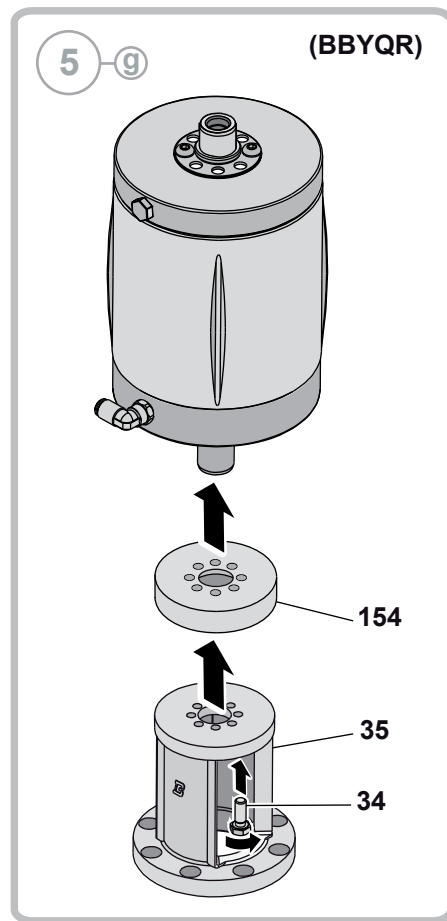

7

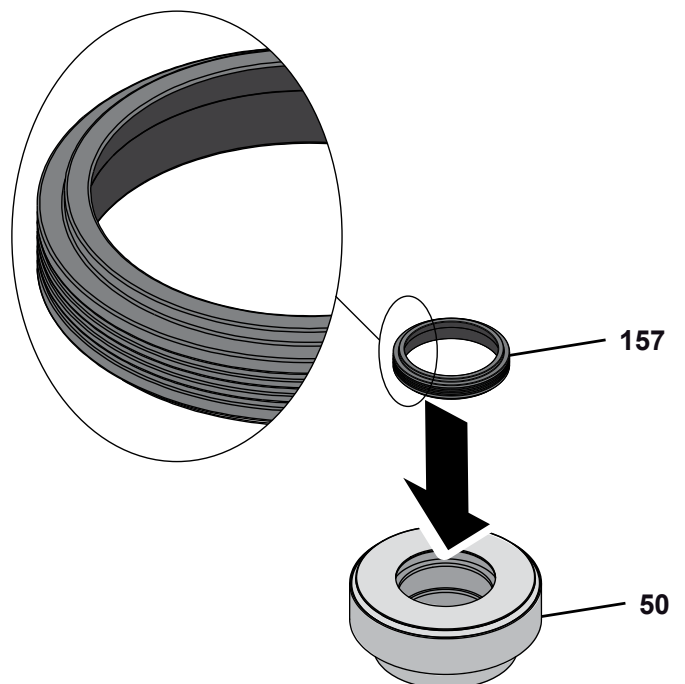
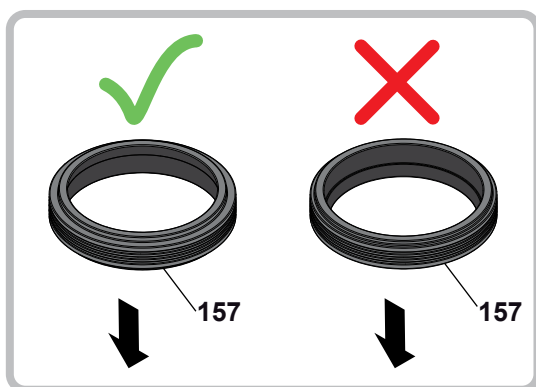

8

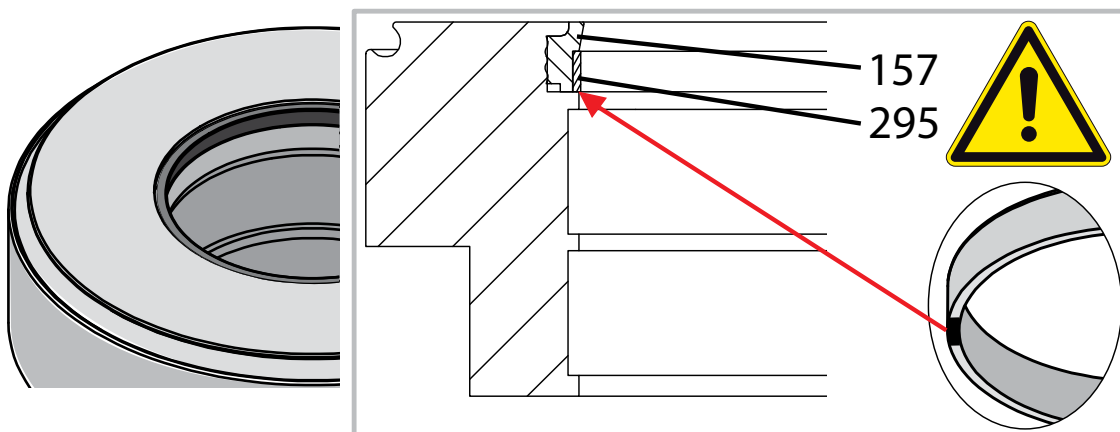
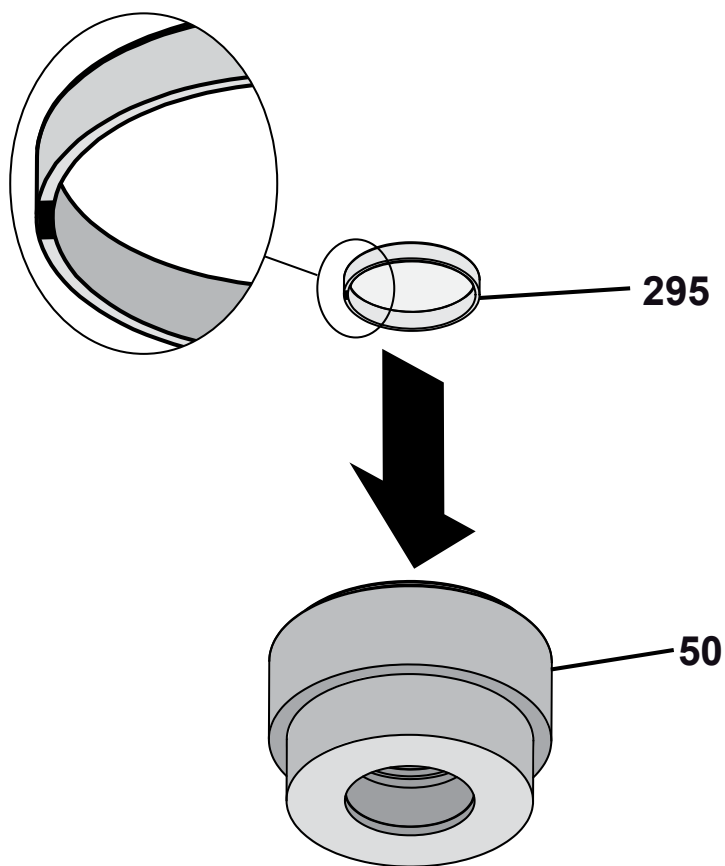

9

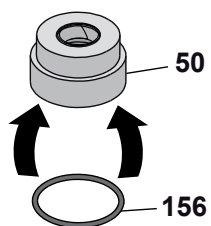

10

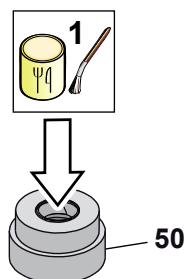

(BBYQ)

6-d

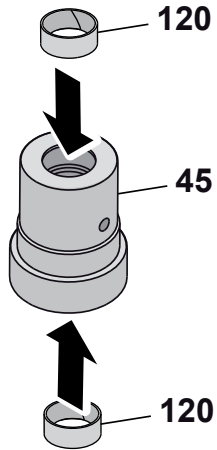

7-d

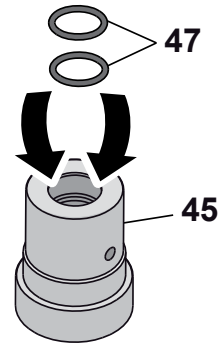

8-d

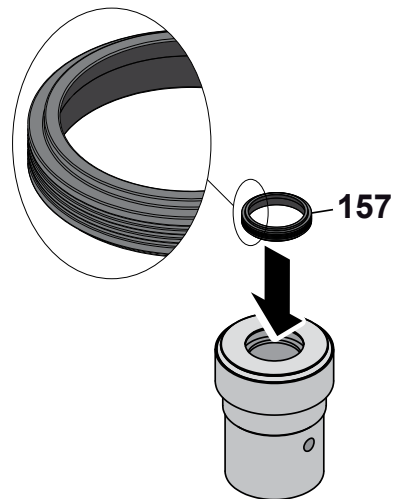
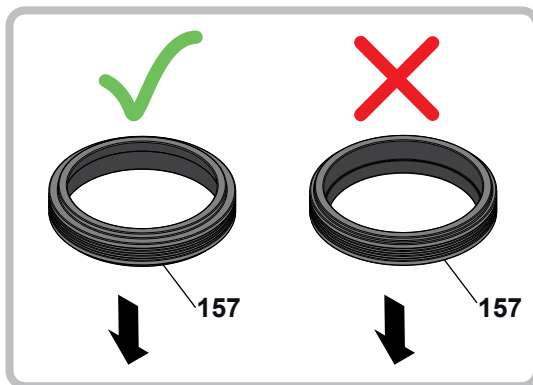

(BBYQ)

9-d

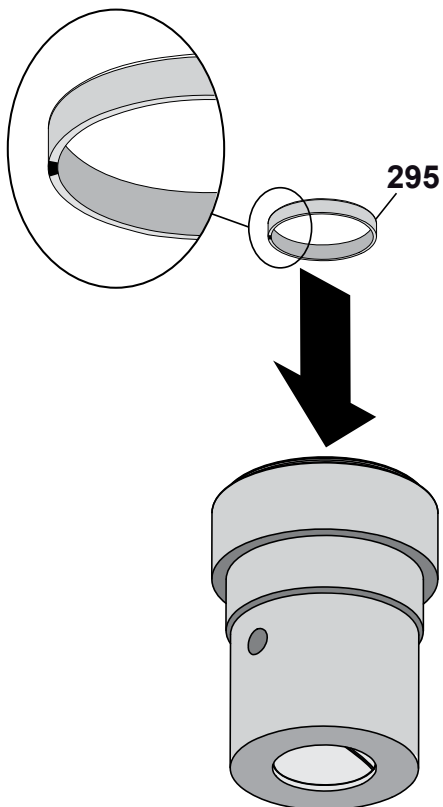

10-d

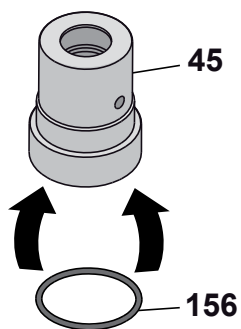

11-d

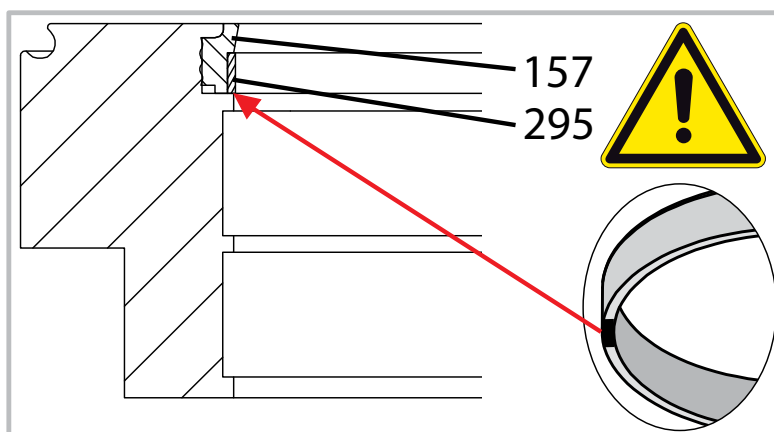
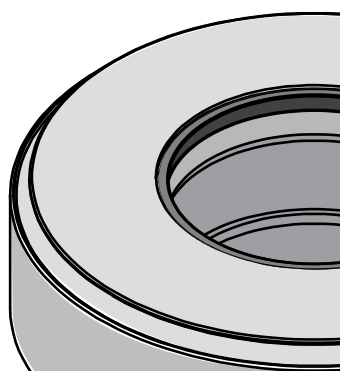
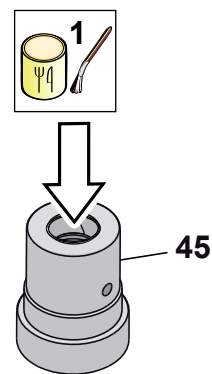

(BBYQ Special execution)

6-f

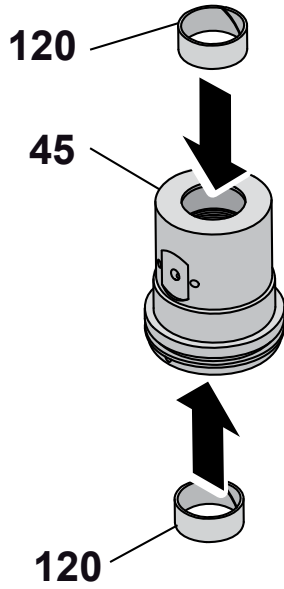

7-f

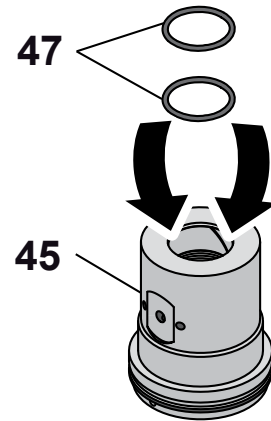

8-f

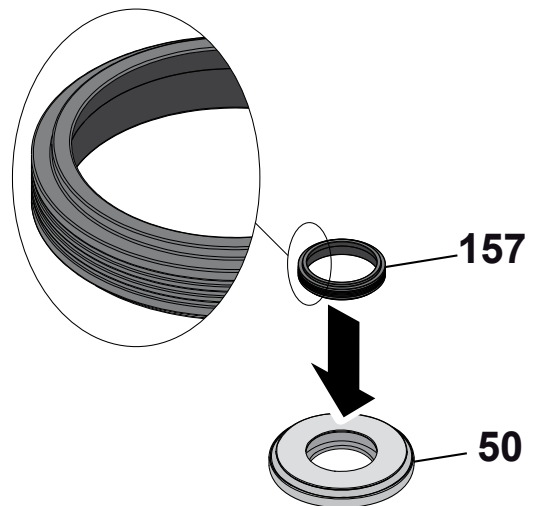
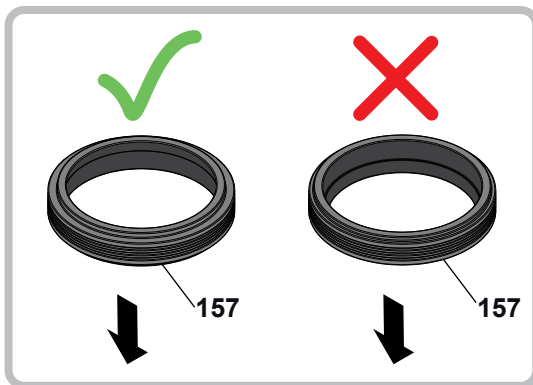

(BBYQ Special execution)

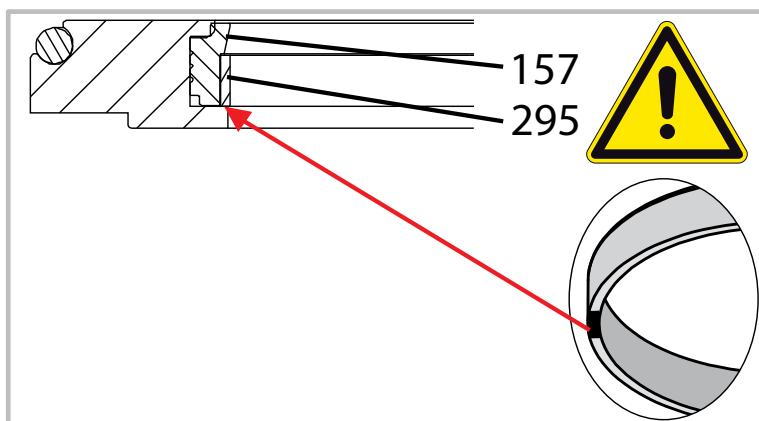
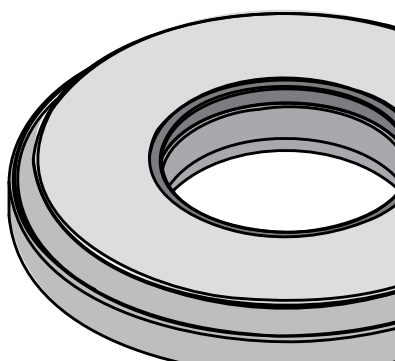
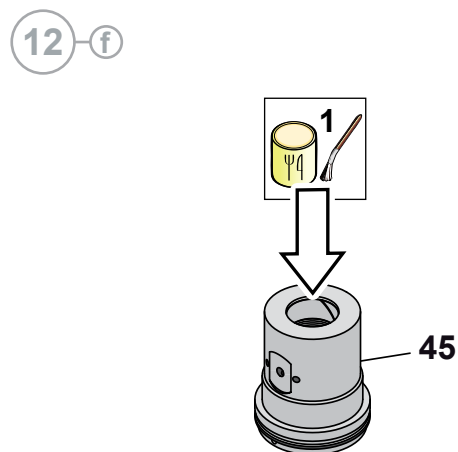
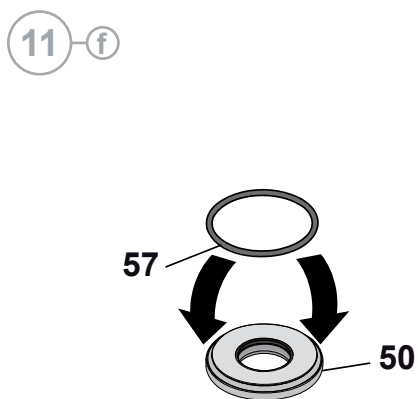
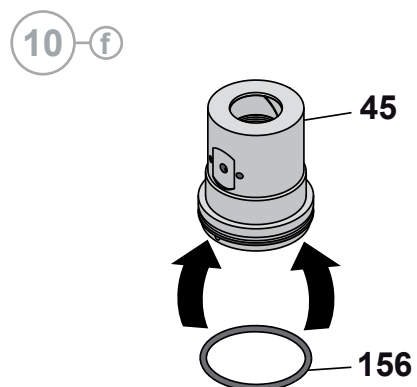
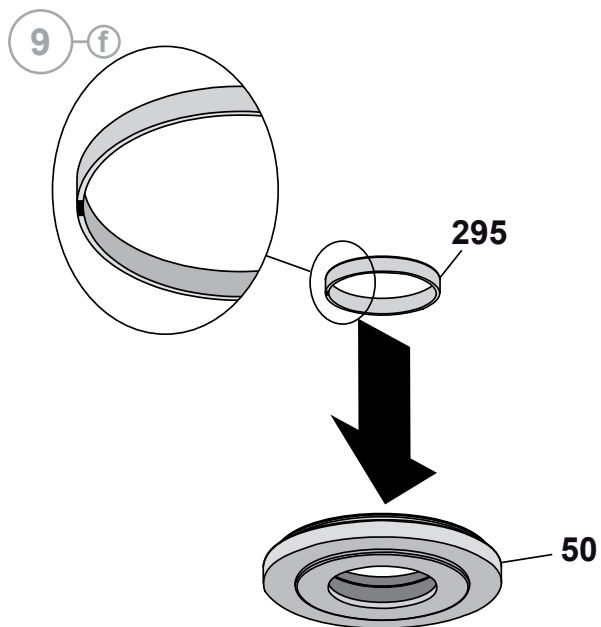

a

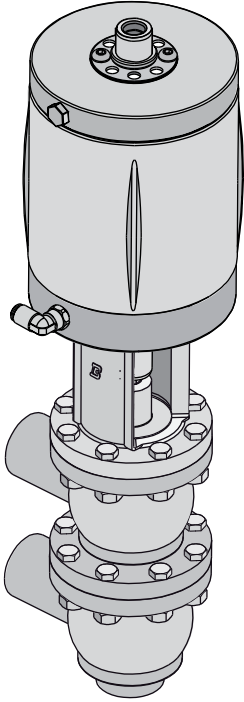

[A M BBZQ-LL108-156]

b

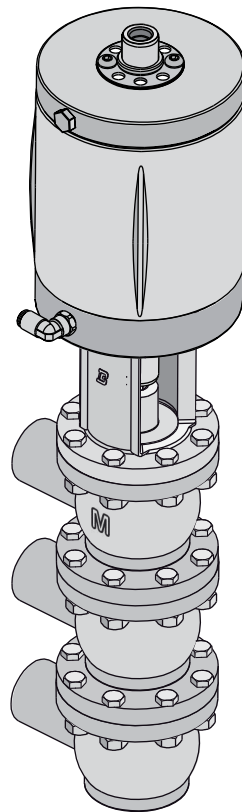

[B M BBZQ-M8-LLL108-156]

A Assembly of the BBZQ - BBYQ LL - BBZQ P7 - BBYQ P7

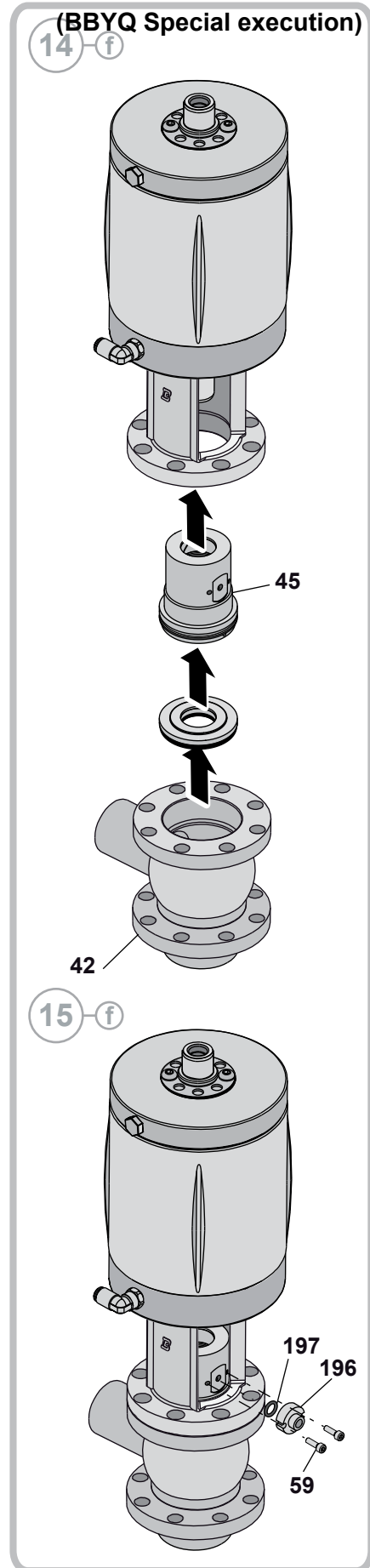
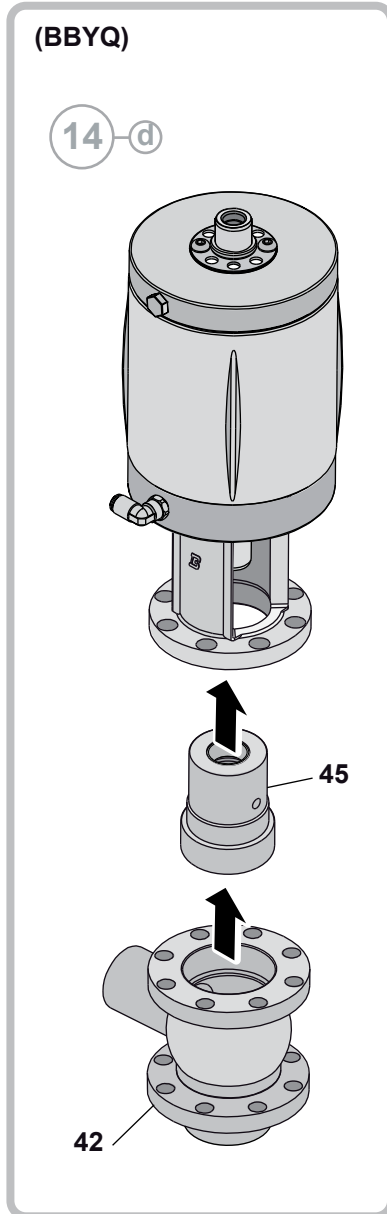
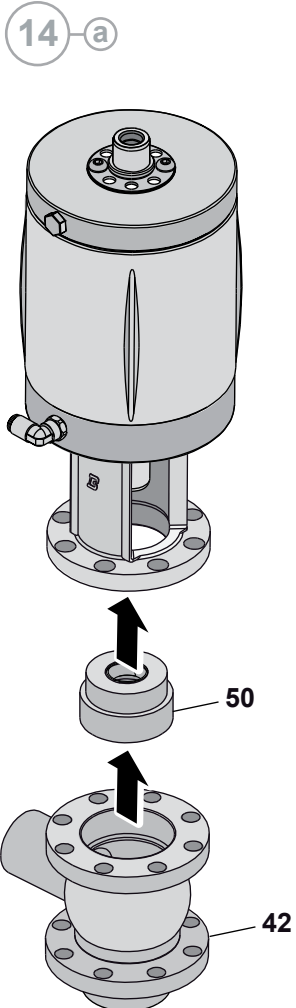
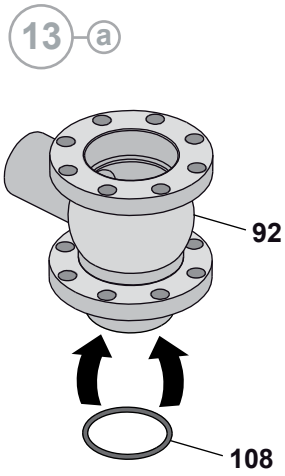

16-a

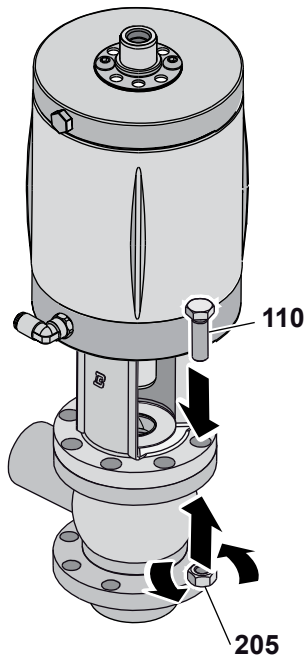

(P.T.F.E.)

17-e

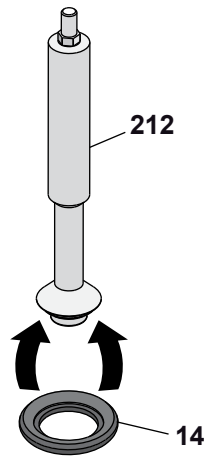

18-d

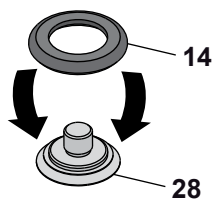

19-e

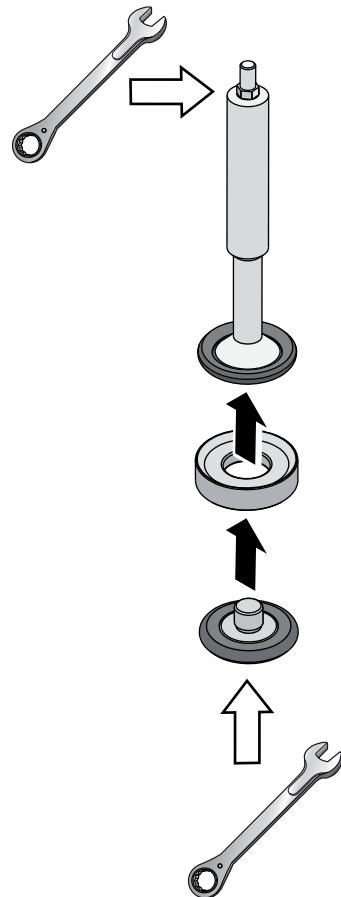

(Normally closed)

20 a1

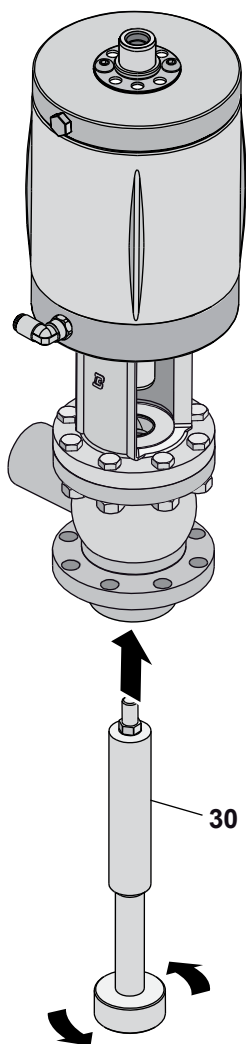

21 a1

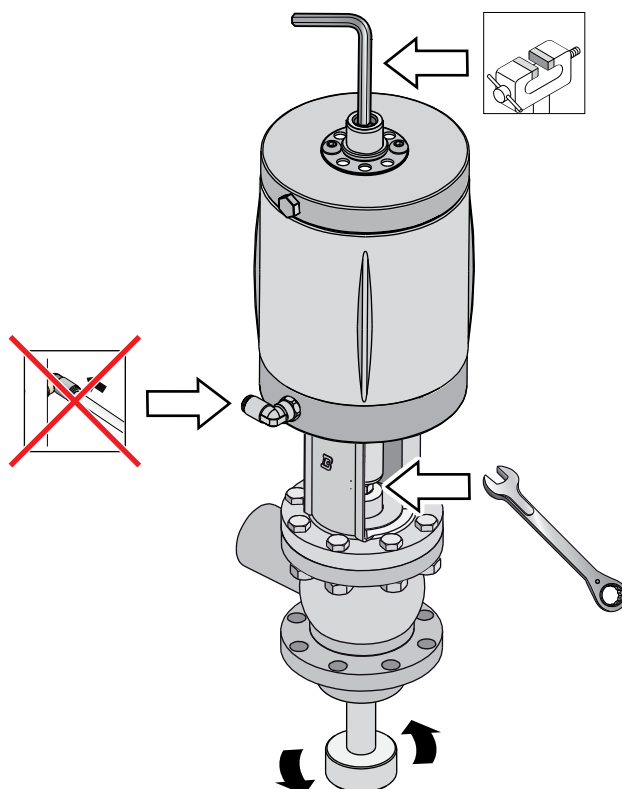

22 a1

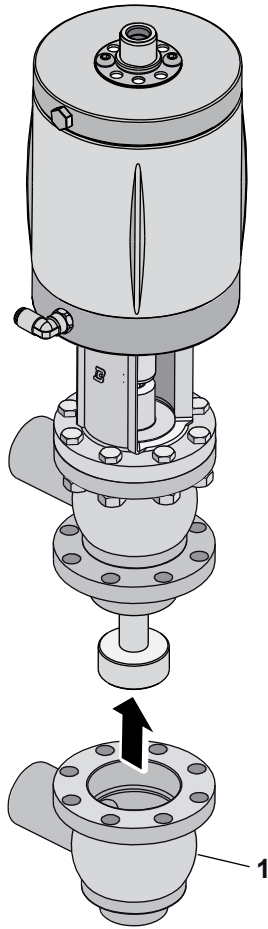

23 a1

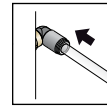

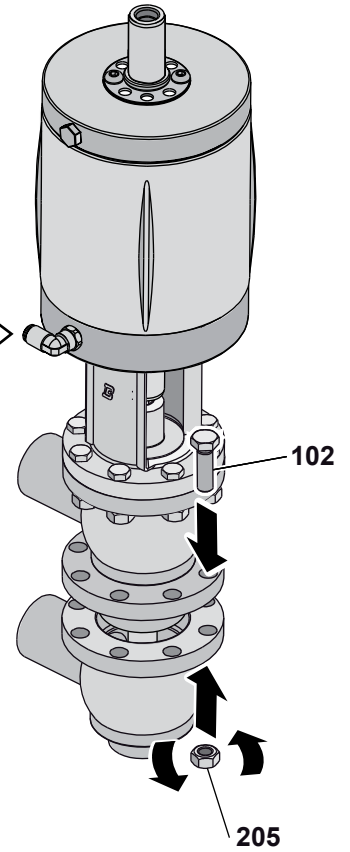

Never touch the moving parts if the actuator is supplied with compressed air

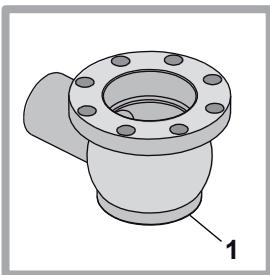

P7

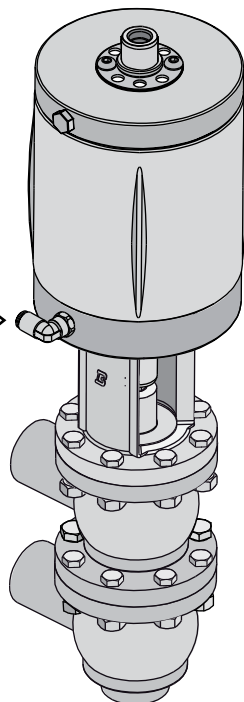
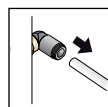

24 a1



(Normally open or double acting)

20 a2

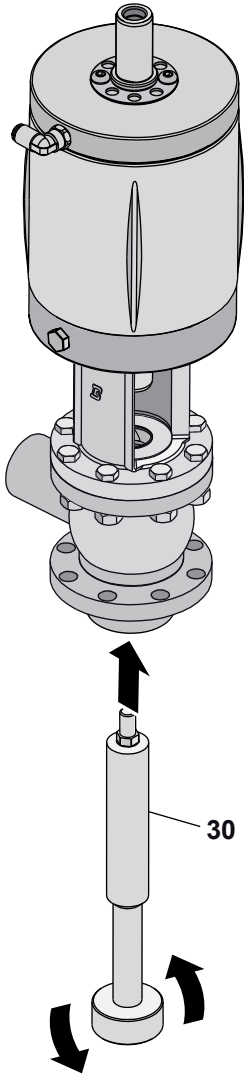

21 a2

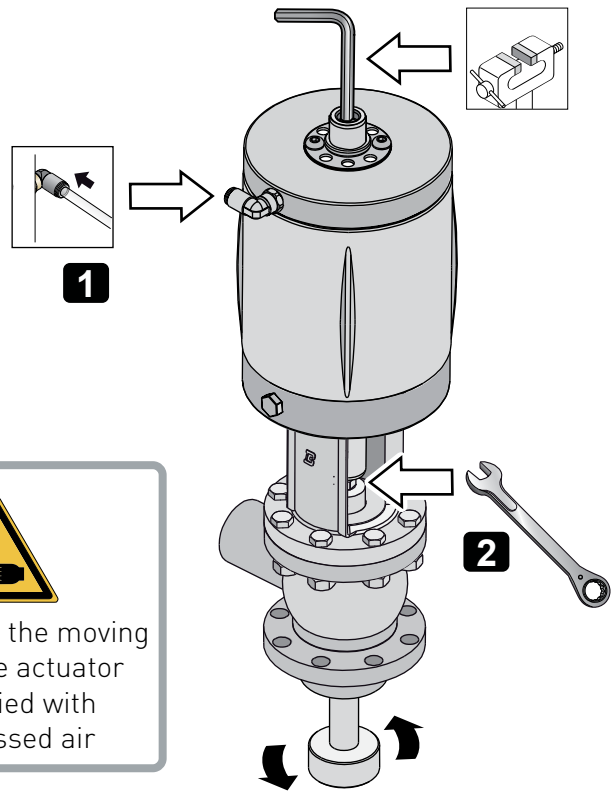

Never touch the moving parts if the actuator is supplied with compressed air

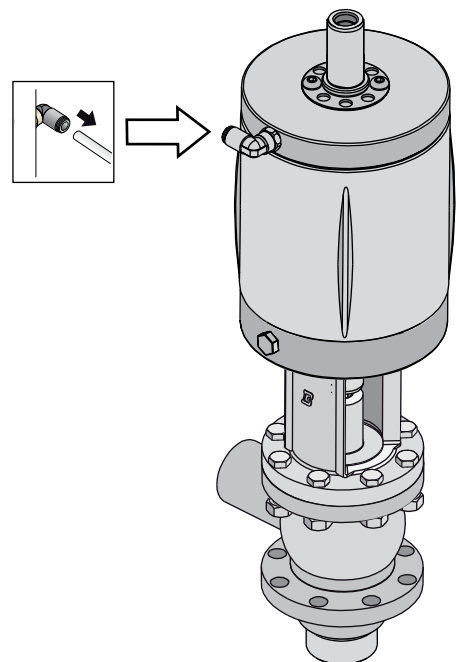

22 a2

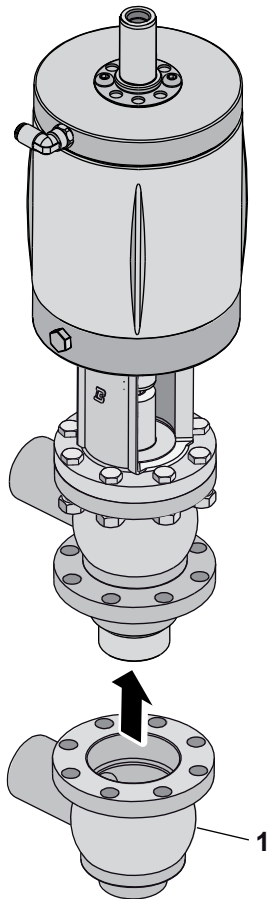

23 a2



24 a2

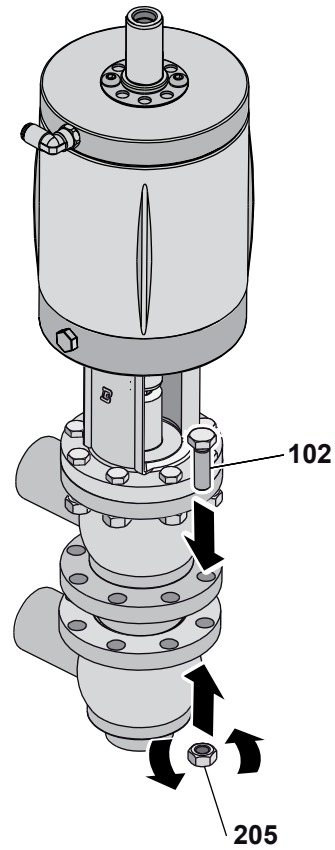

25 a2

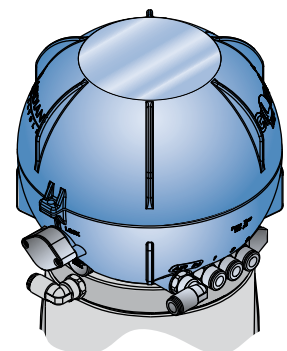
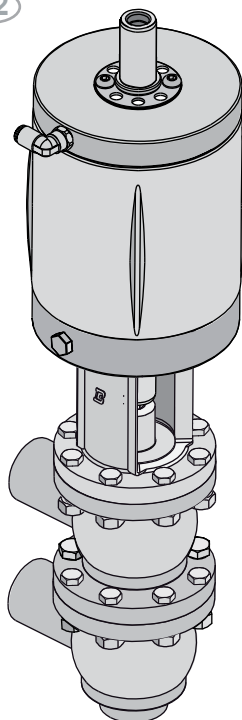

[M GIOTTO]

B Assembly of the BBZQ - M8-LLL

(BBYQ Special execution)

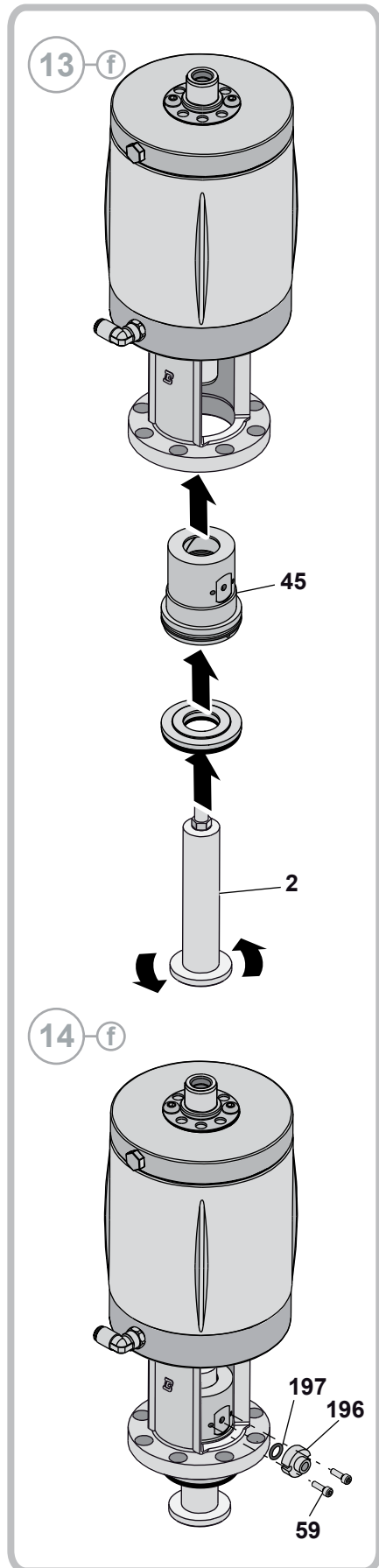
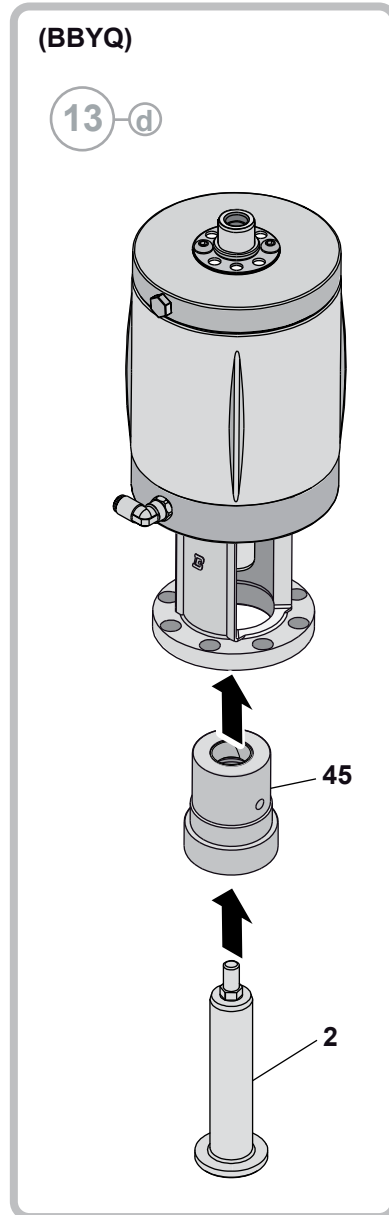
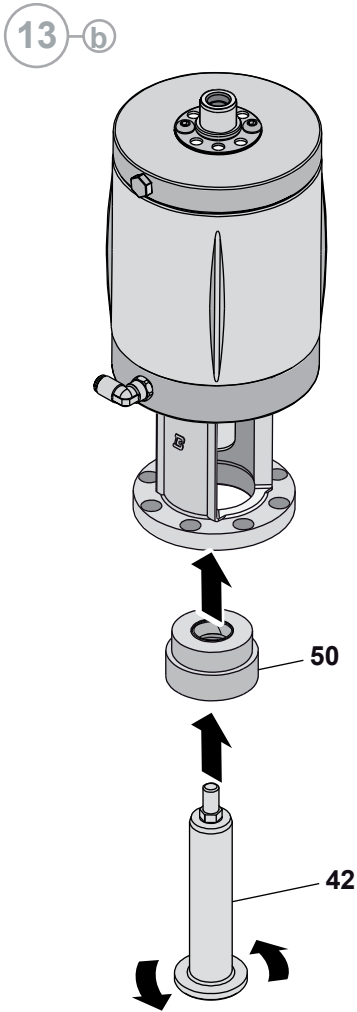

15-b

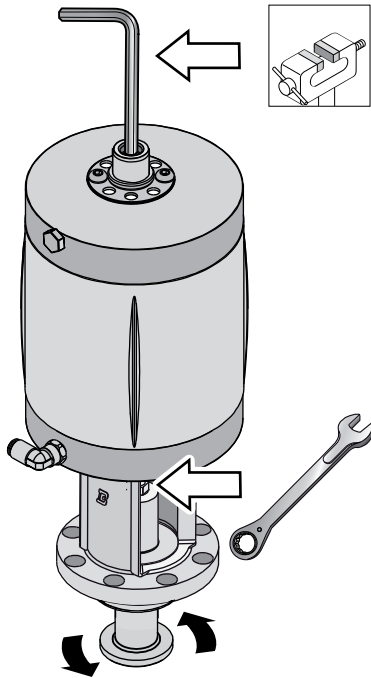

16-b

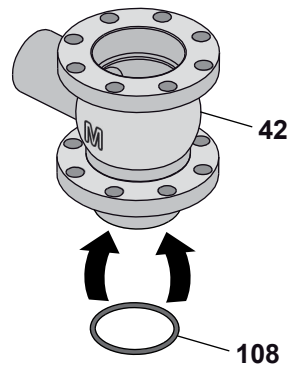

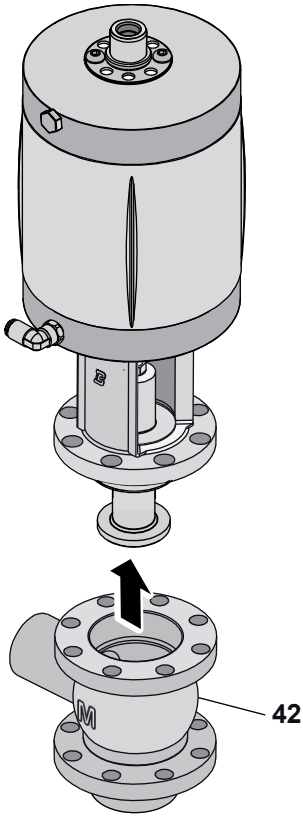

(Normally closed)

17 b1

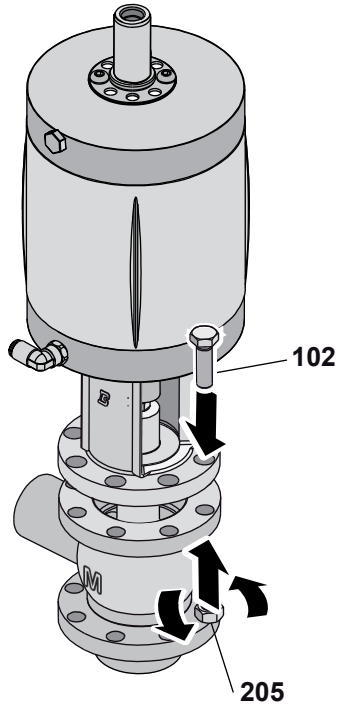
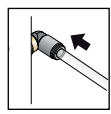

18 b1



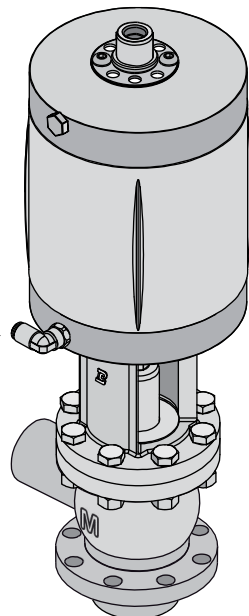
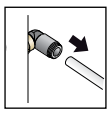

Never touch the moving parts if the actuator is supplied with compressed air

19 b1

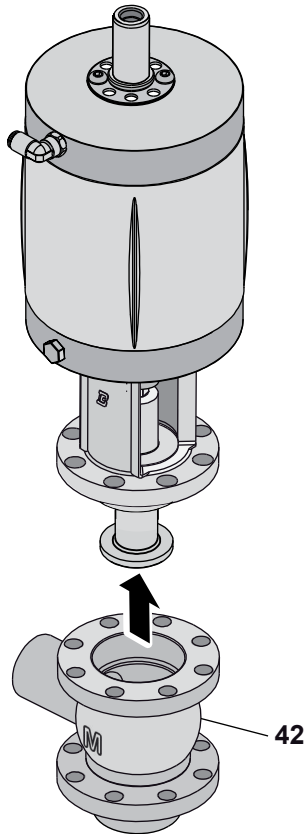

(Normally open or double acting)

17 b2



18 b2

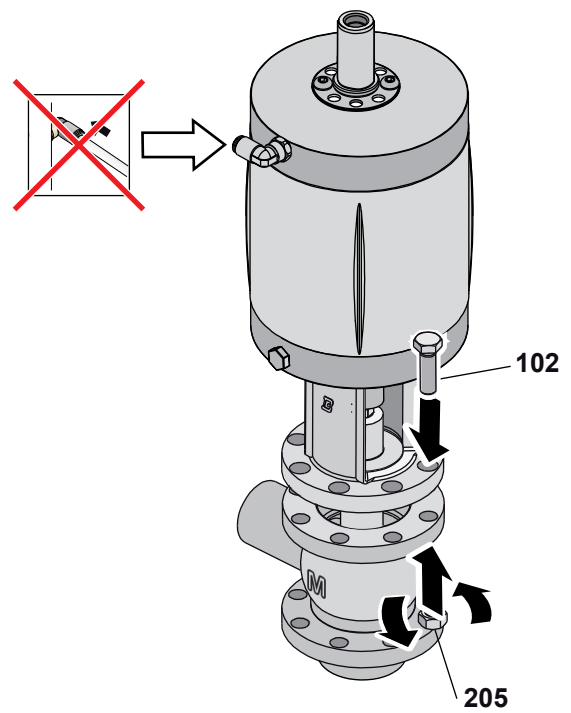

20-b

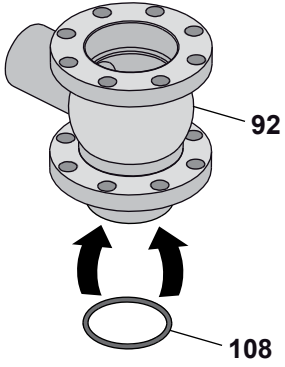

21-b

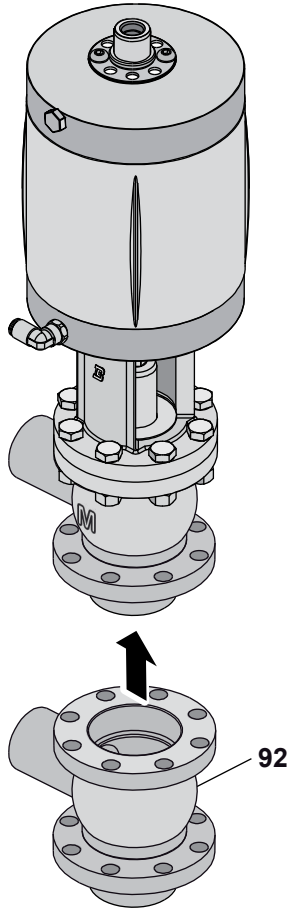

22-b

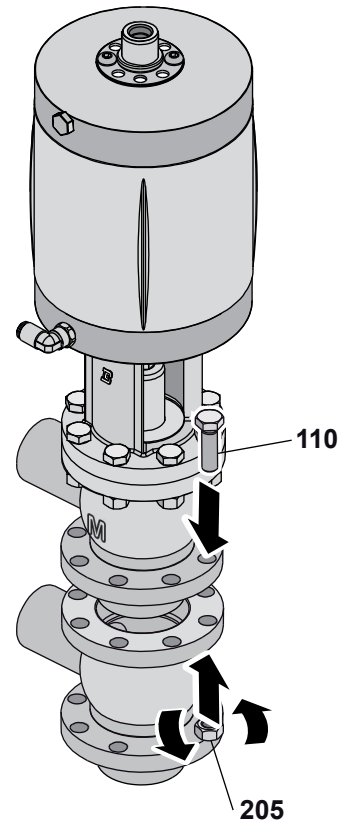

23-b

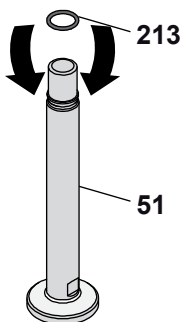

(Normally closed)

24 b1

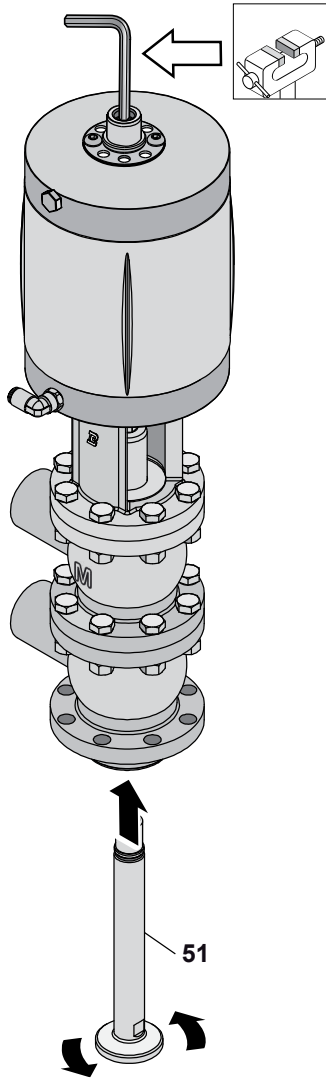

25 b1

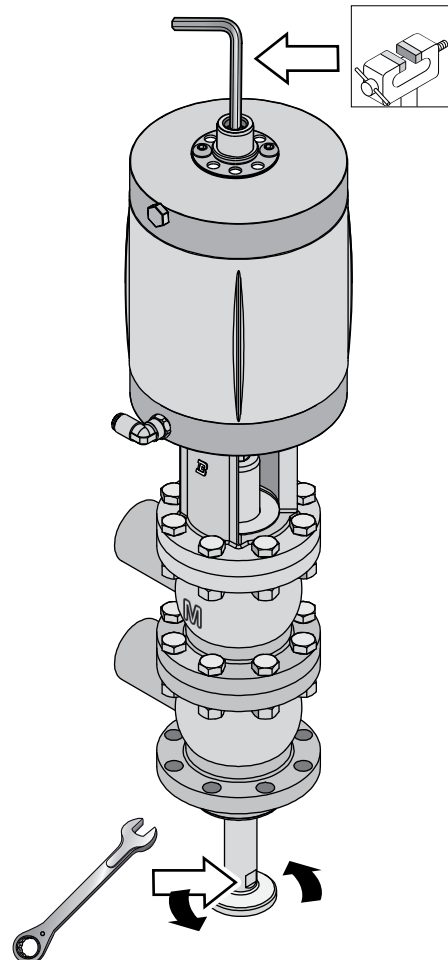

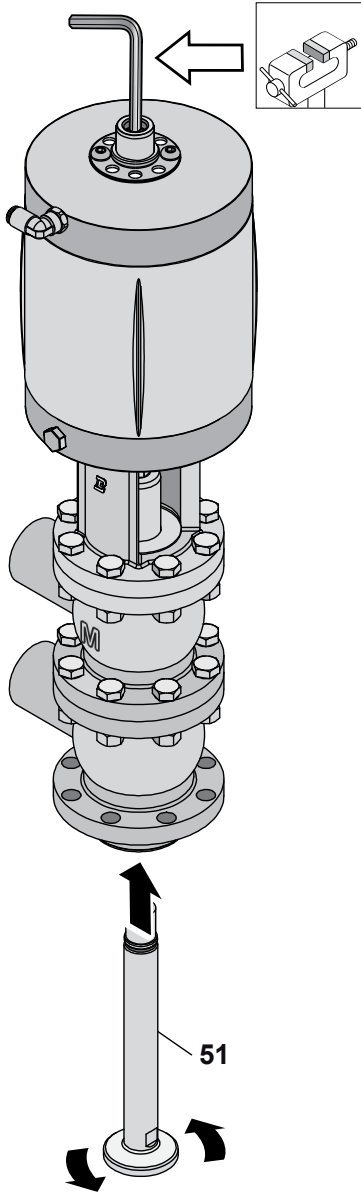

(Normally open or double acting)

24 - b2

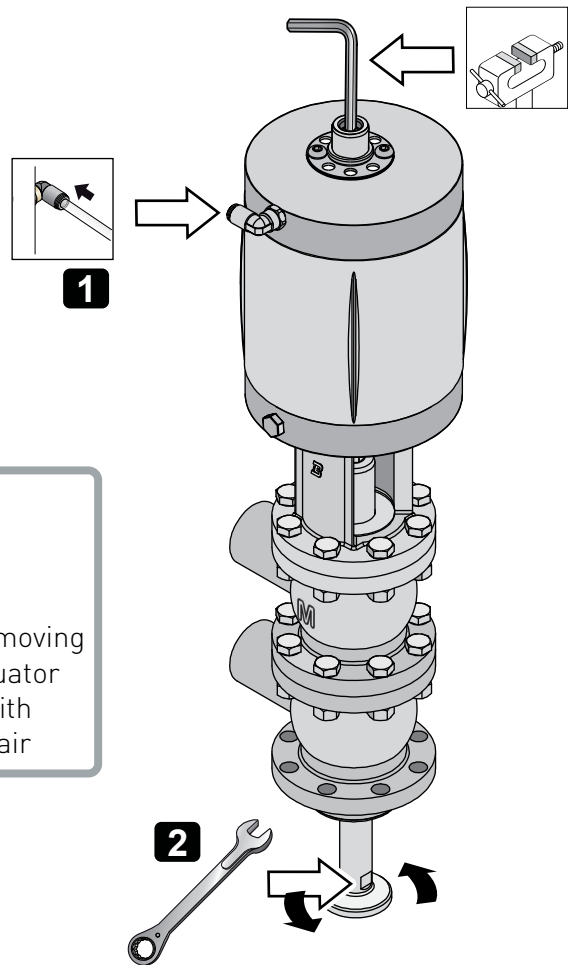

25 - b2



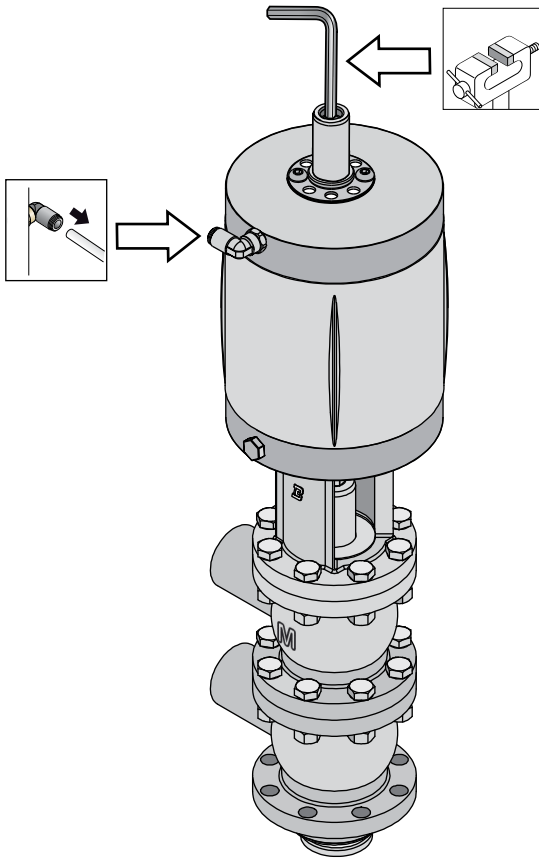

Never touch the moving parts if the actuator is supplied with compressed air

26-b2

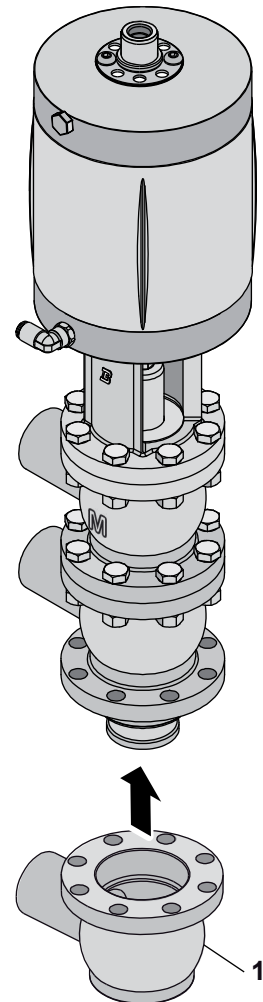

27-b



28 b

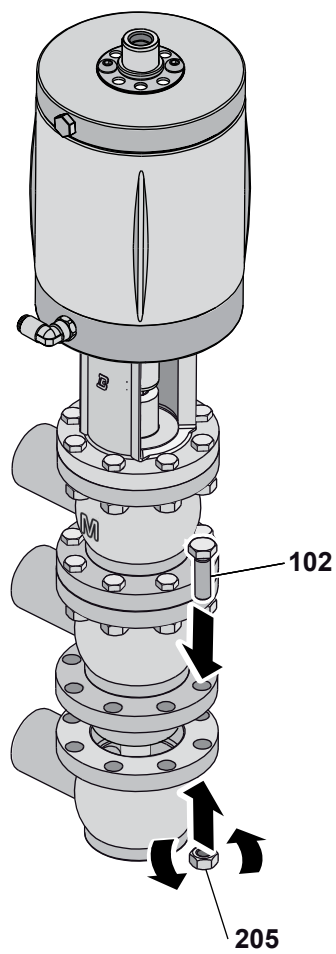

34

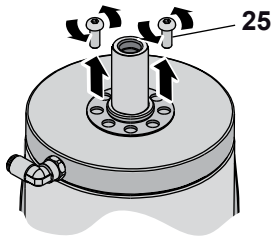

35

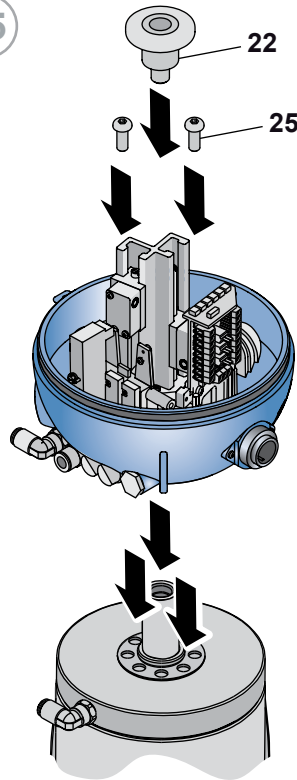

36

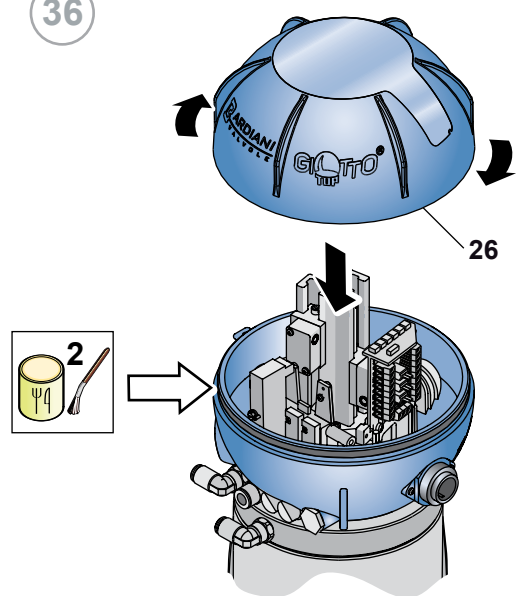

37

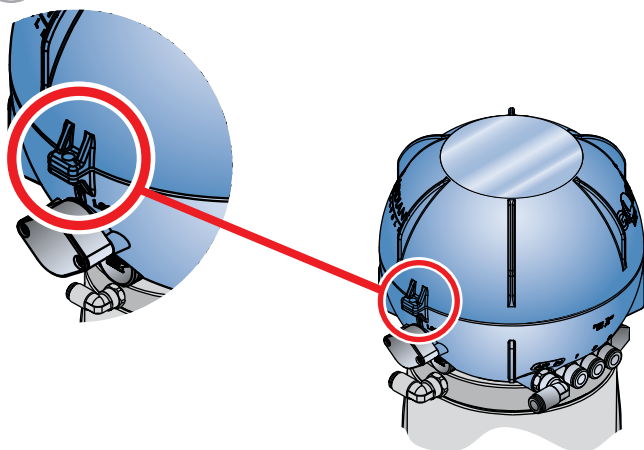

10.10 Pneumatic Valve BBZQ - BBYQ cylinder 207-360

NO.	DESCRIPTION
1	Lower body
2	Shutter
4	Sealing ring
6	Sealing ring
9	Cylinder
10	Bush
11	Pin
12	Sealing ring
13	Piston
16	Sealing ring
17	Bush
18	Buffer
19	Sealing ring
24	Air connector
31	Spring
34	Screw
35	Assembly
45	Steam barrier
47	Sealing ring
50	Gasket holder disc
57	Sealing ring
59	Screw
77	Nut
101	Screw
110	Screw
120	Bush
150	Bottom stopper
156	Sealing ring
157	Sealing ring
196	Steam connector
197	Sealing ring
205	Nut
225	Sealing ring
295	Bush

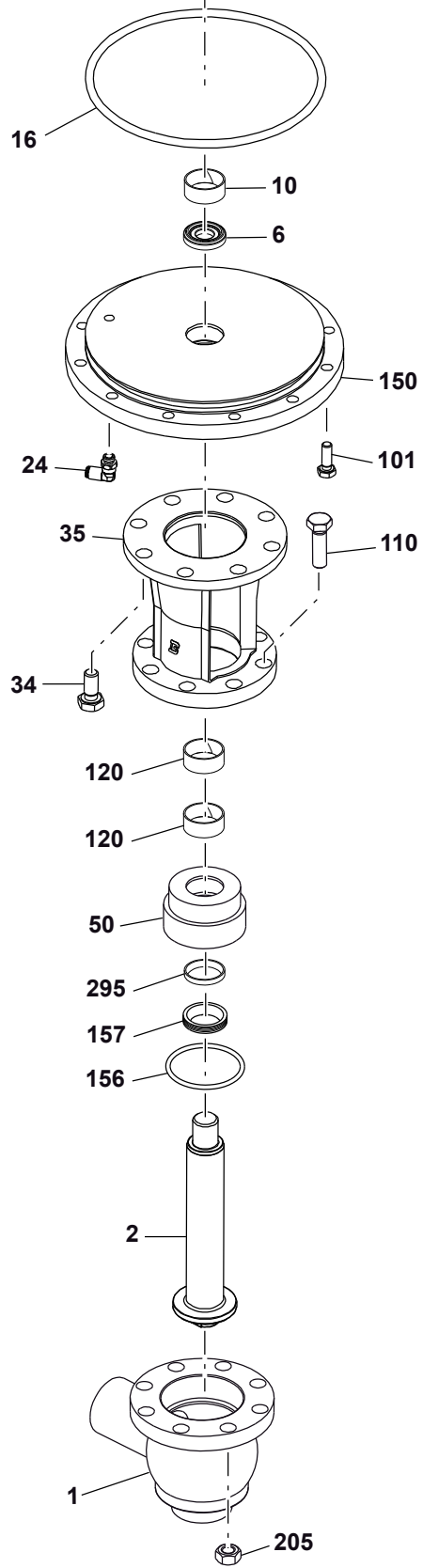
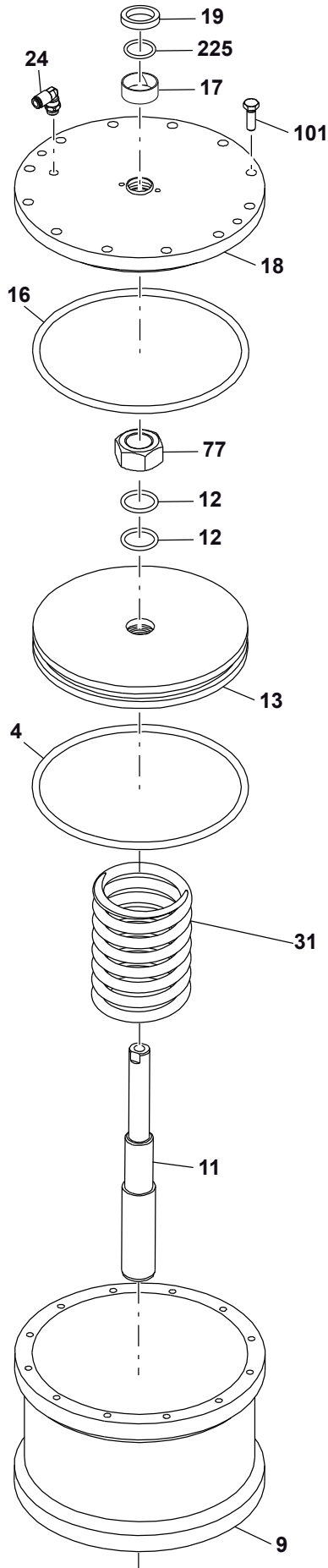

(BBYQ Special execution)

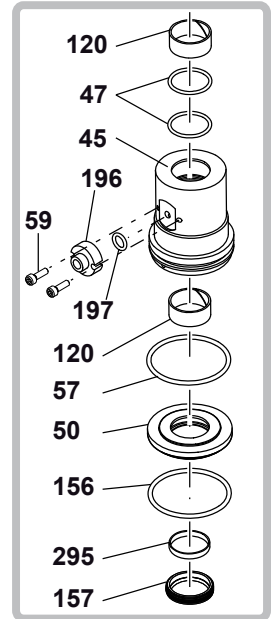

(BBYQ)

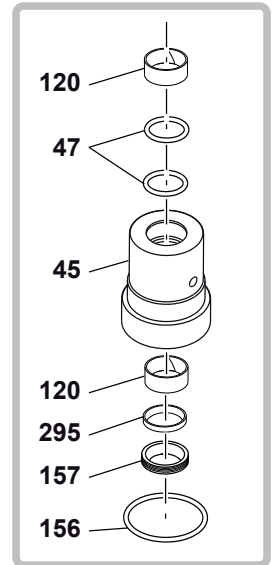

10.11 Disassembly of the BBZQ - BBYQ cylinder 207-360

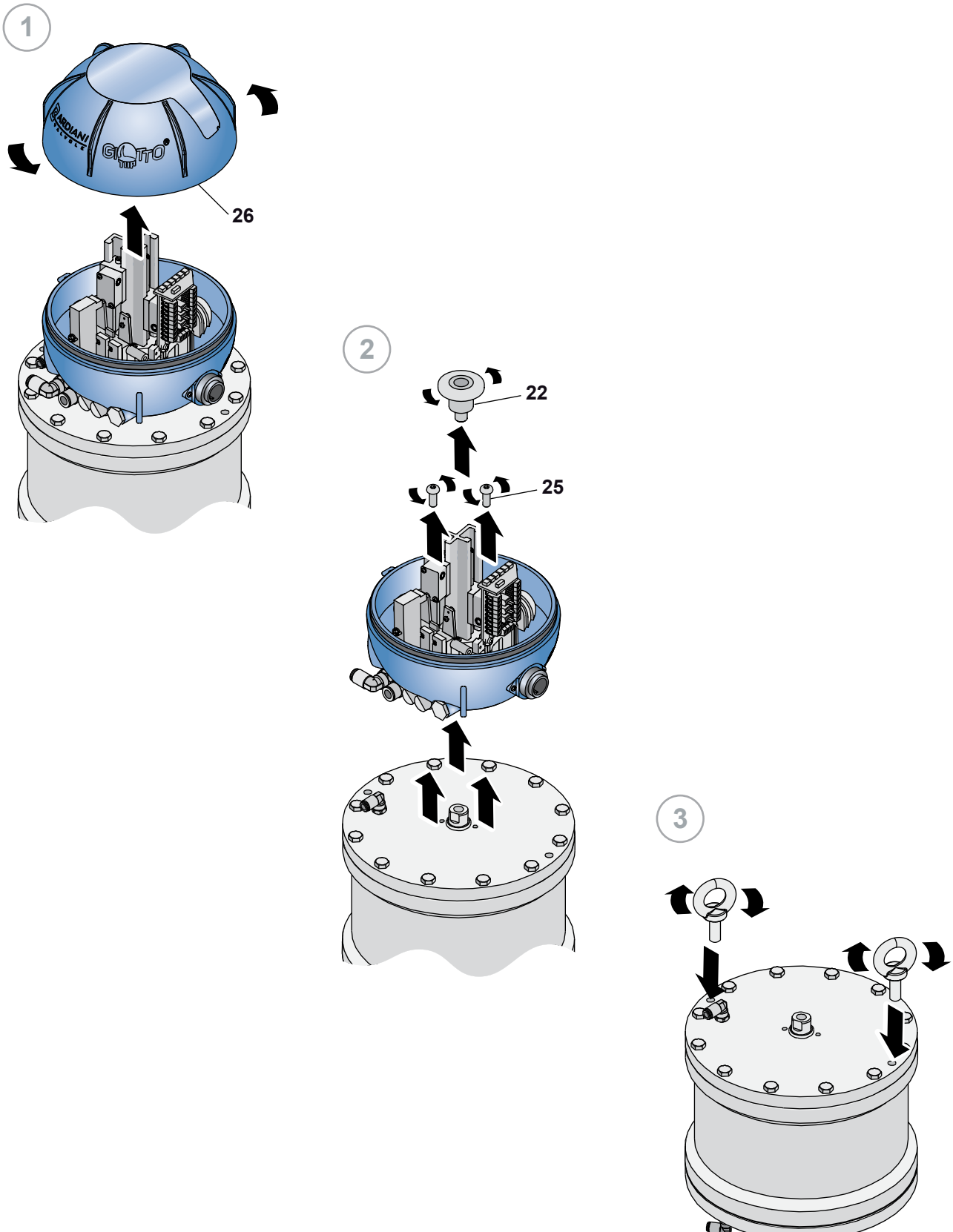

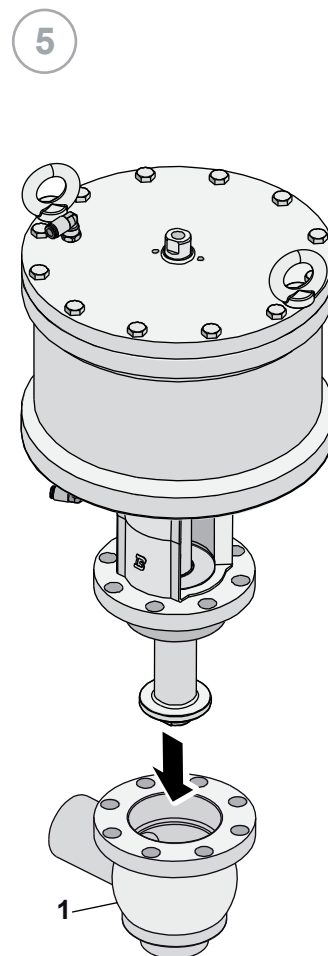
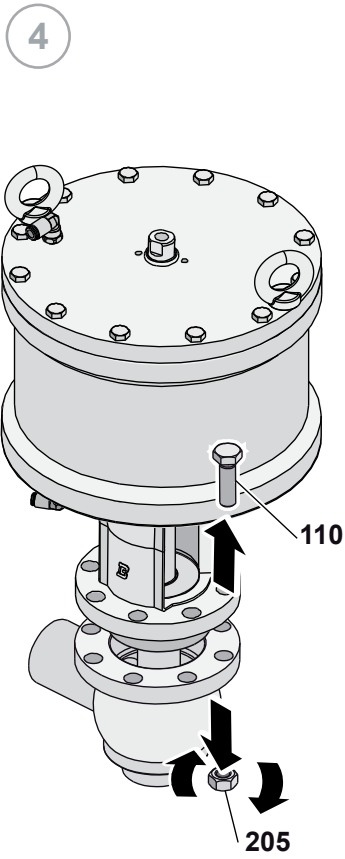

(M8)

6 a

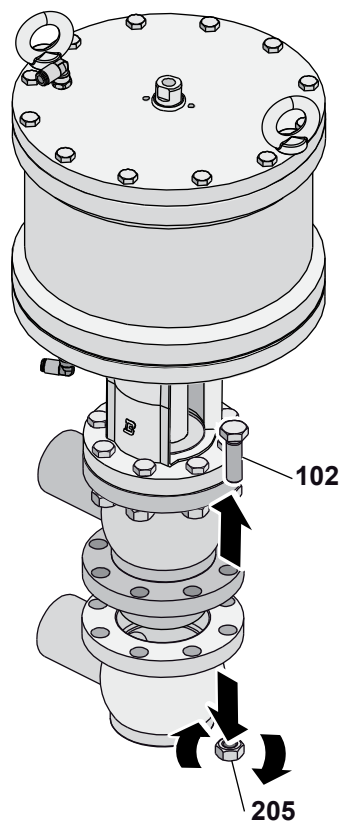

7 a

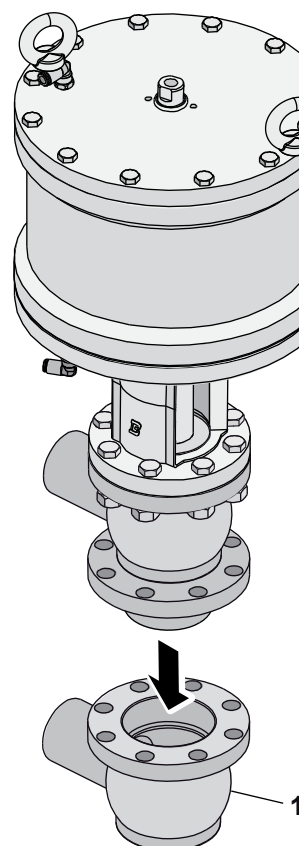

8 a

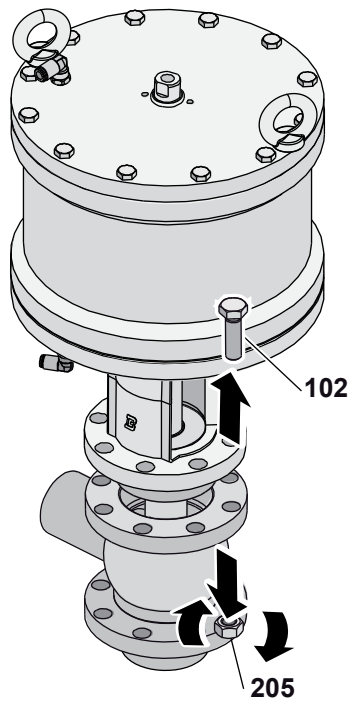

9 a

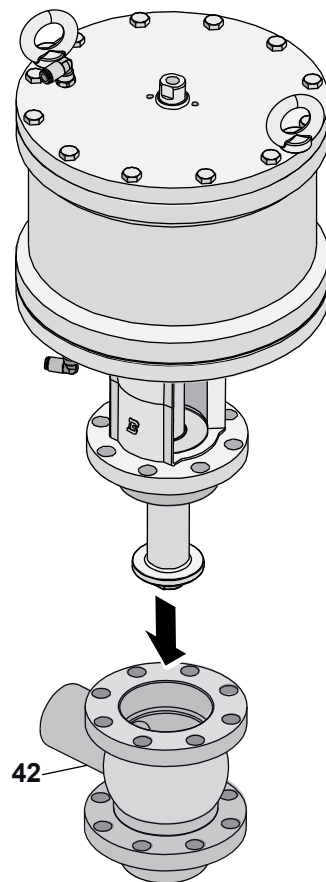

10

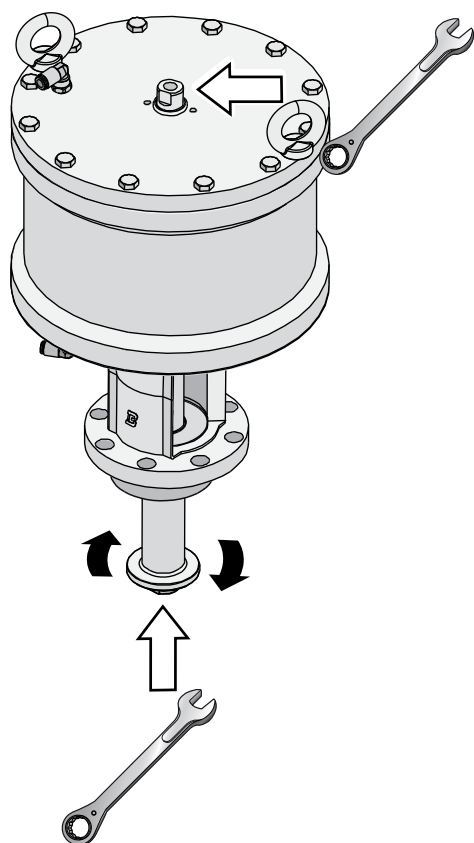

11

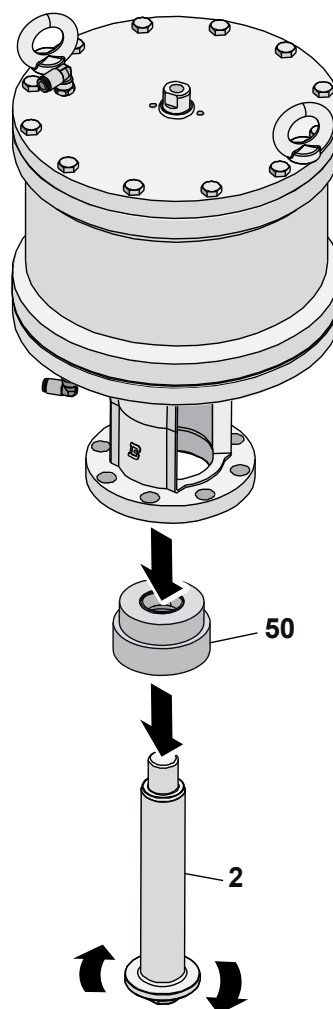

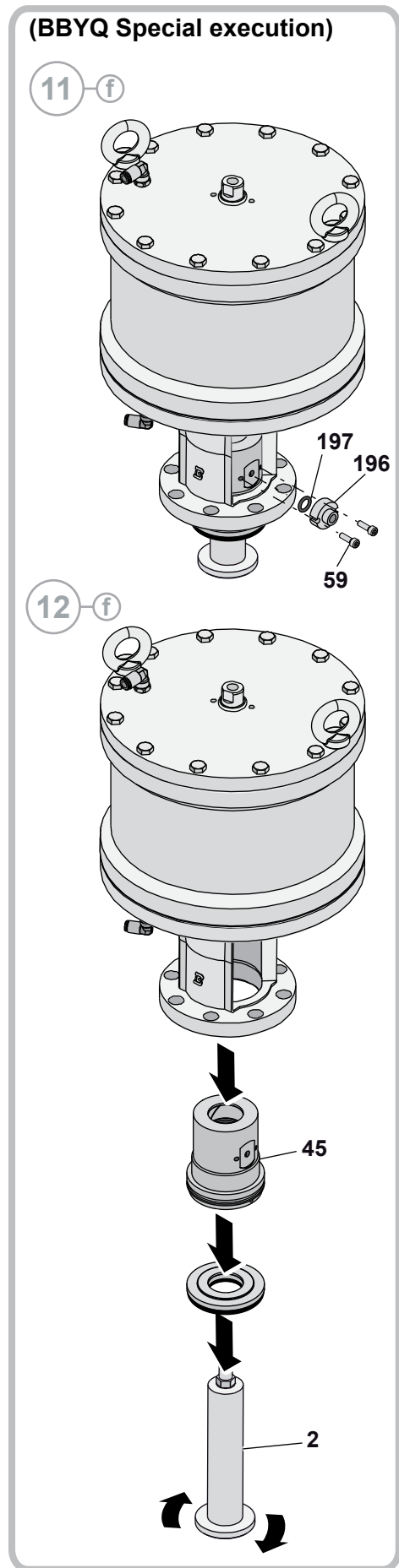
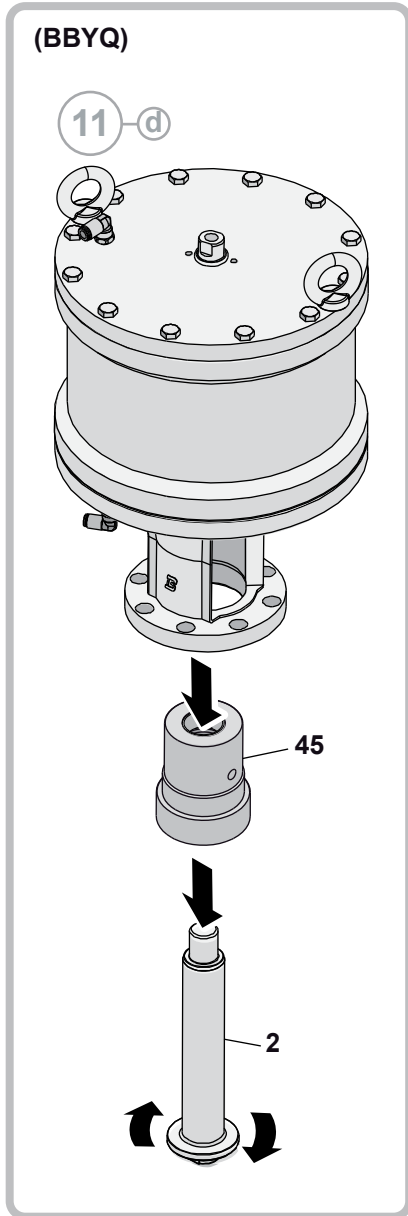

13

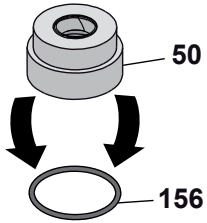

14

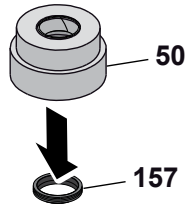

15

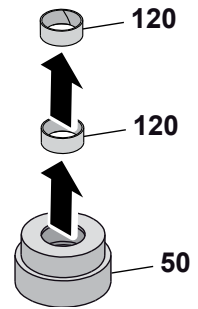

(BBYQ)

13-d

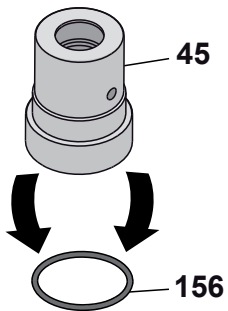

14-d

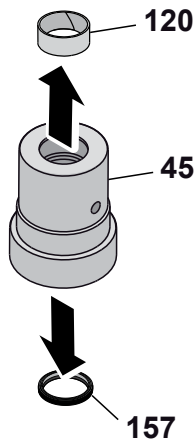

15-d

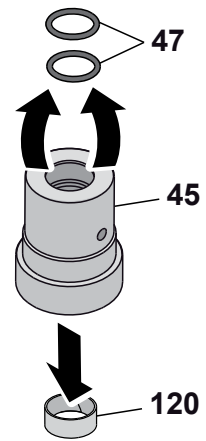

(BBYQ Special execution)

13-f

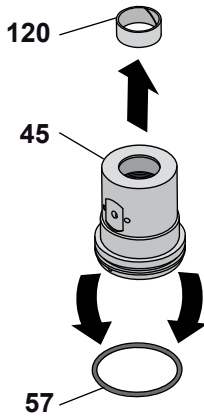

14-f

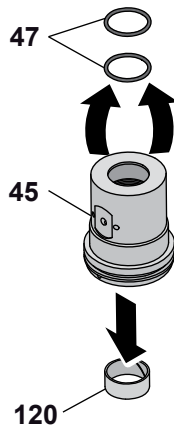

15-f

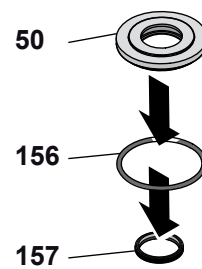

(Double acting)

16-a

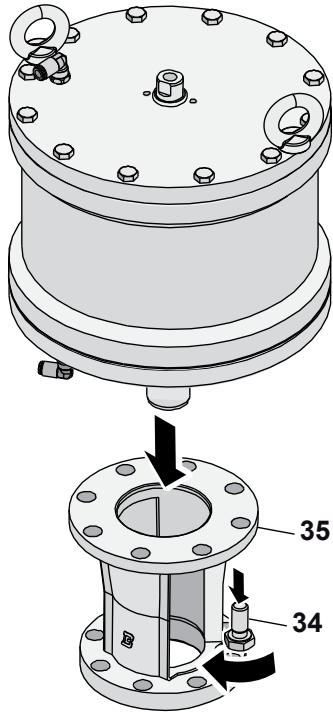

17-a

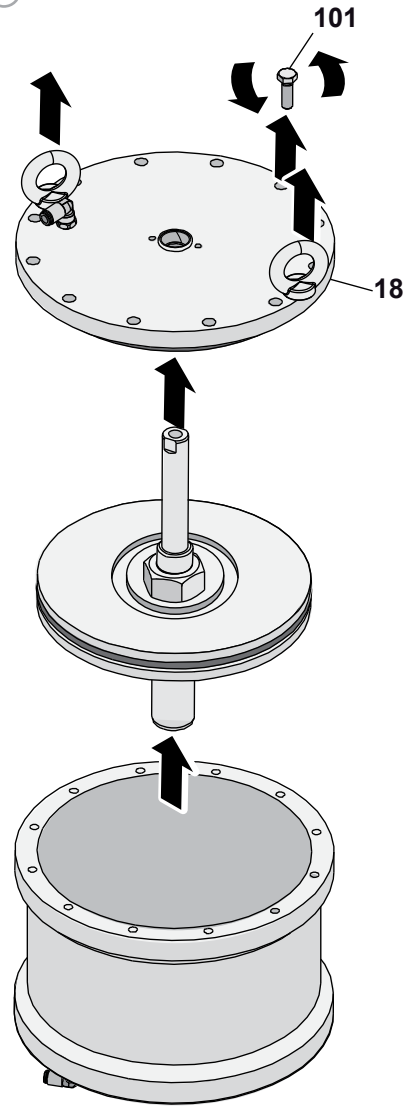

18-a

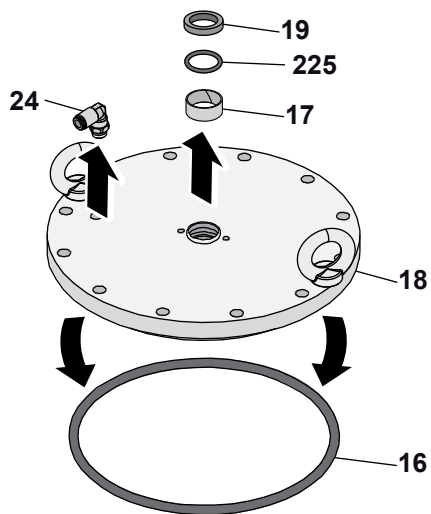

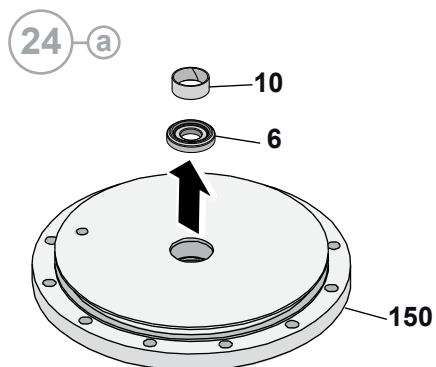
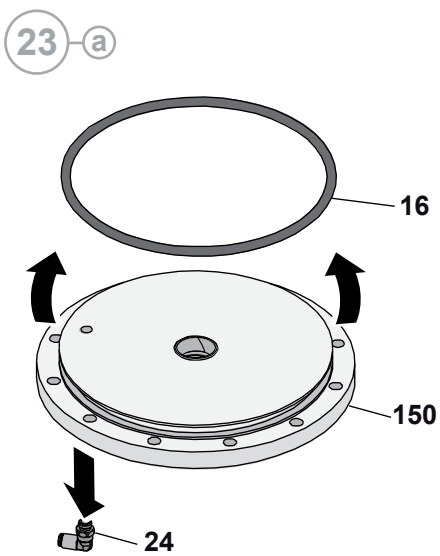
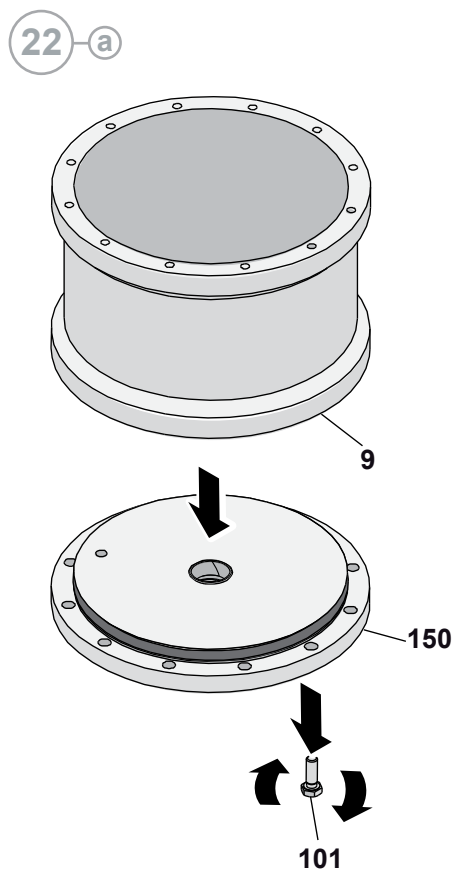
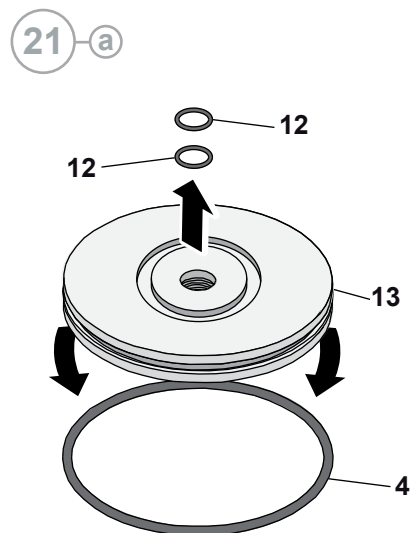
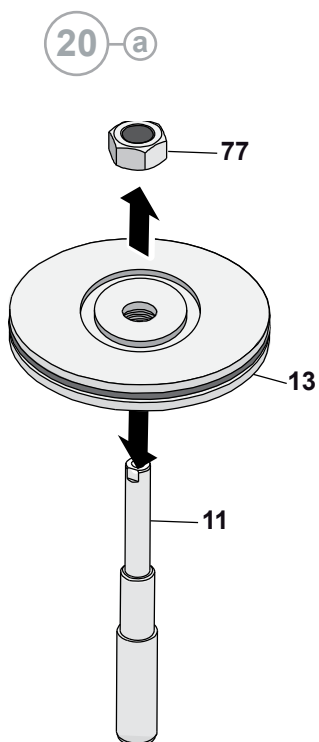
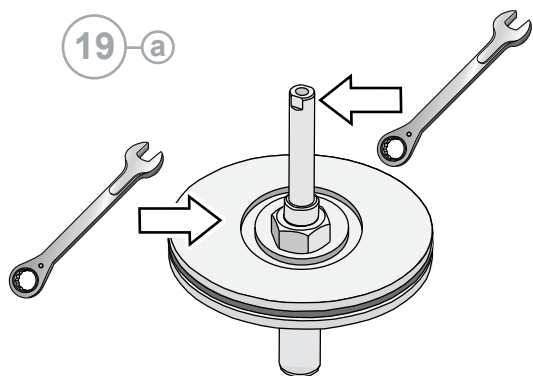

(Normally closed)

16-b

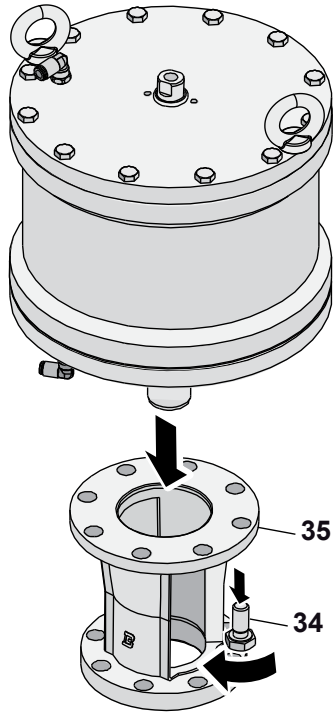

17-b

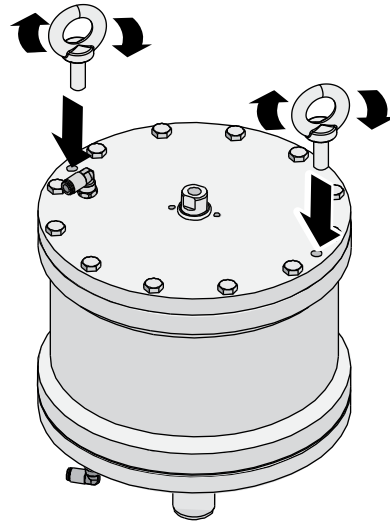

18-b

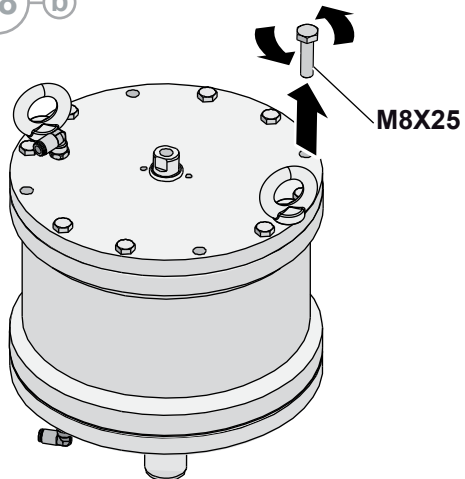

19-b

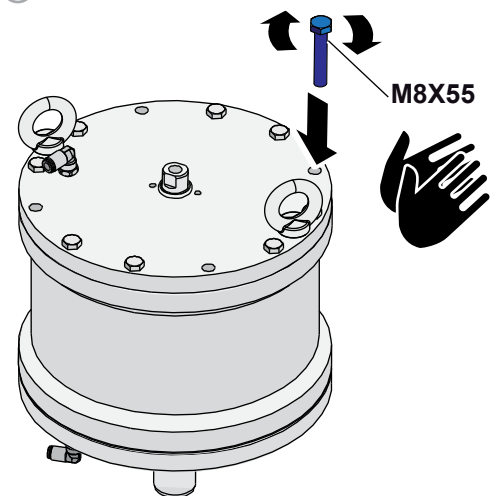

20-b

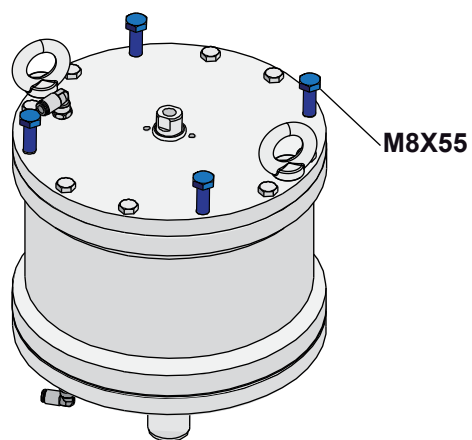

21-b

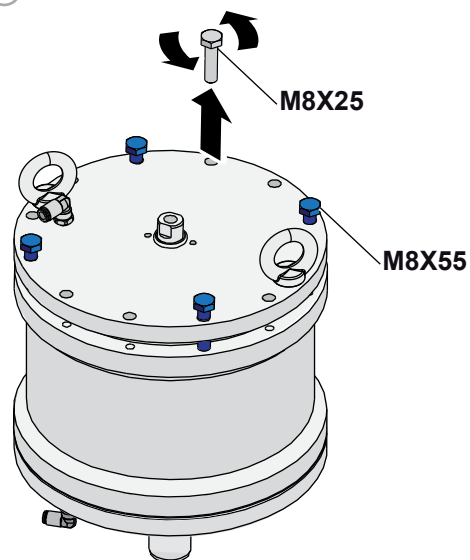
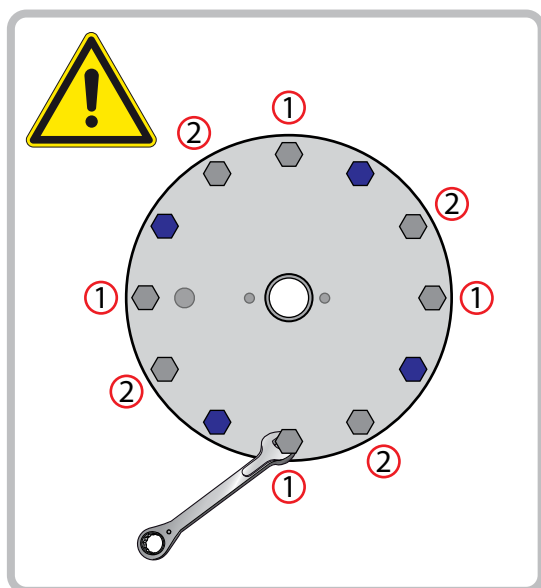

22-b

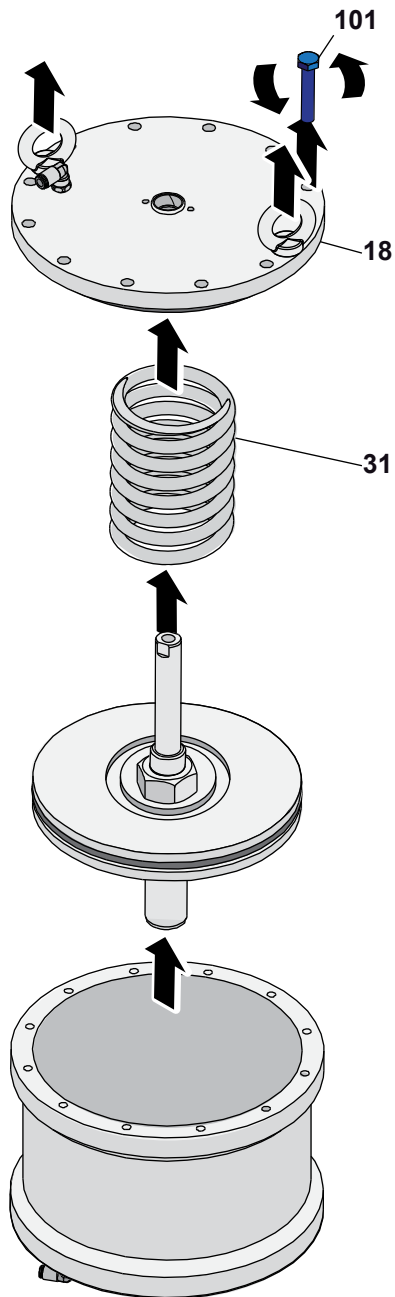

23-b

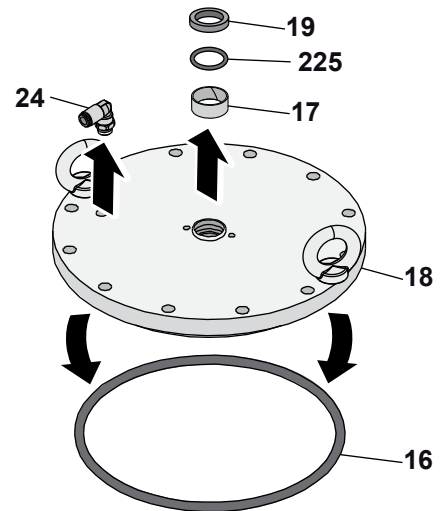

24-b

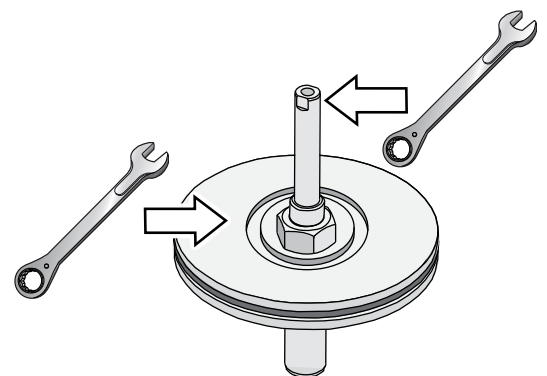

25-b

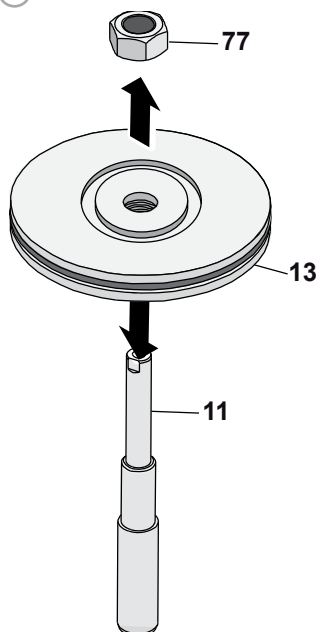

26-b

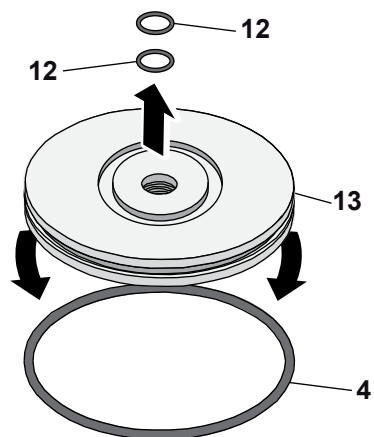

27-b

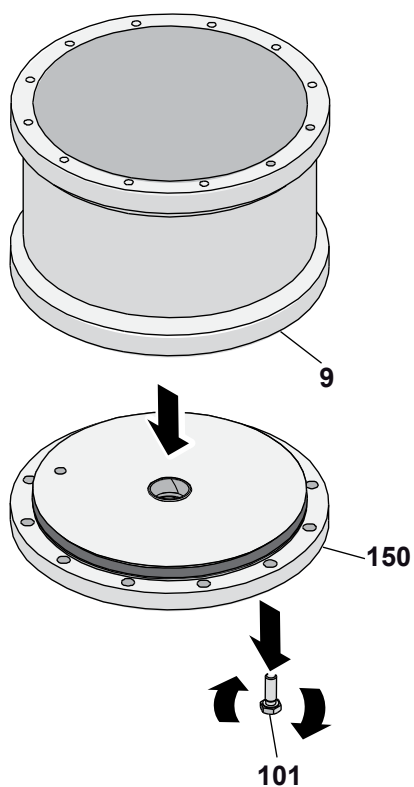

28-b

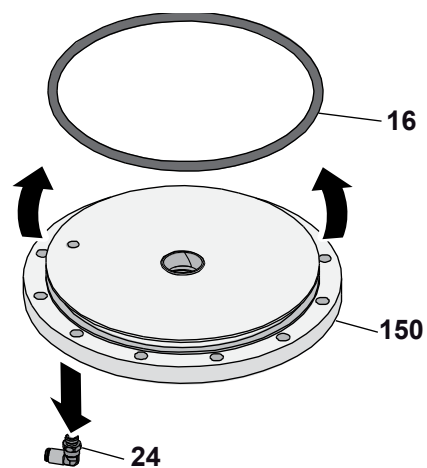

29-b

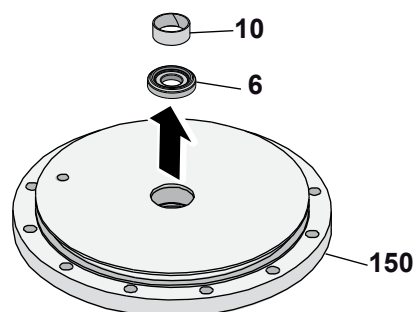

10.12 Assembly of the BBZQ - BBYQ cylinder 207-360

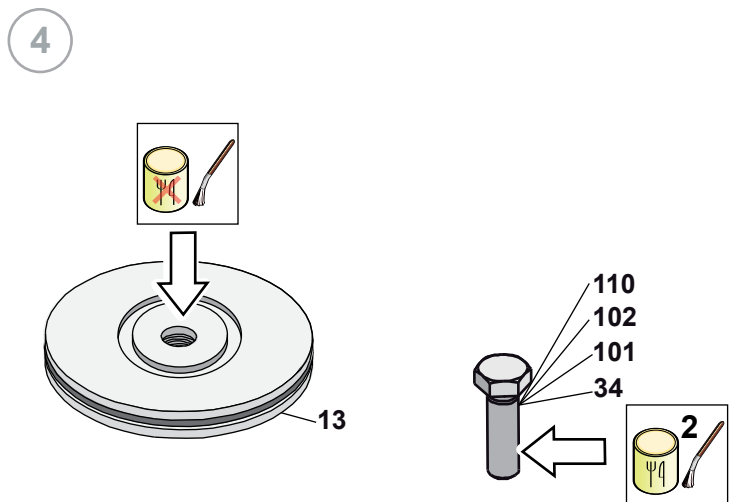
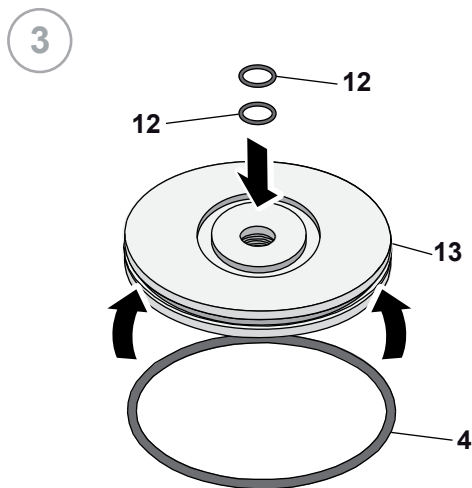
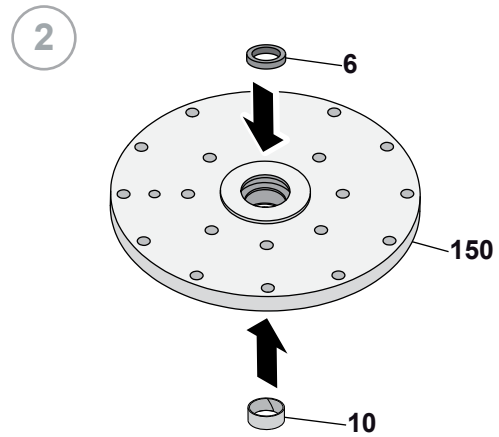
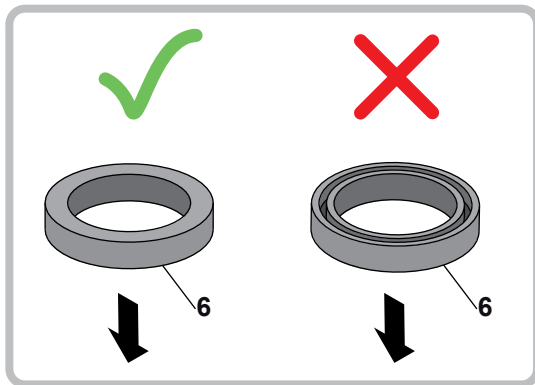
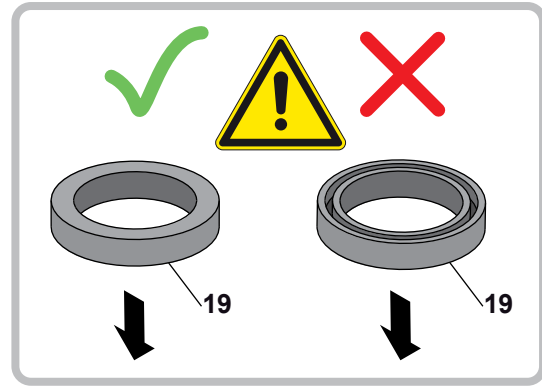
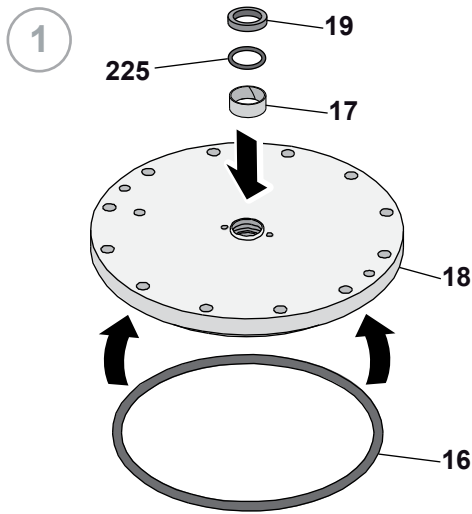

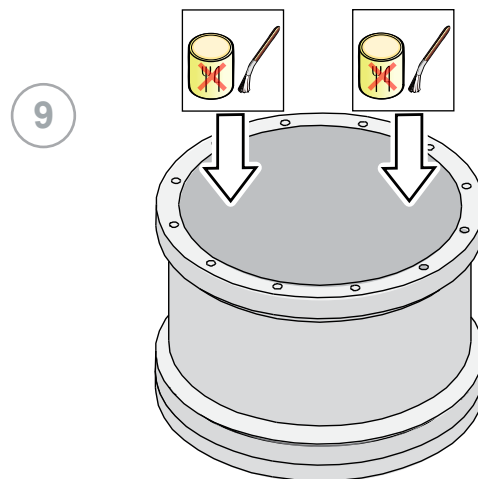
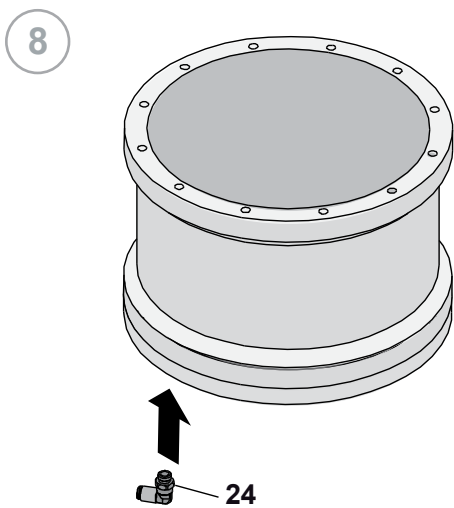
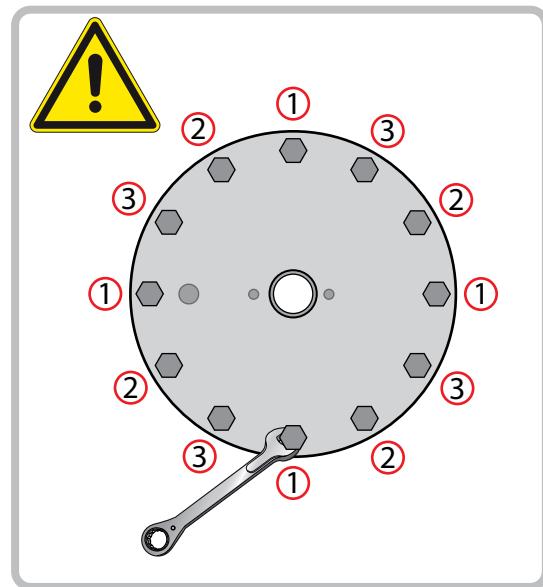
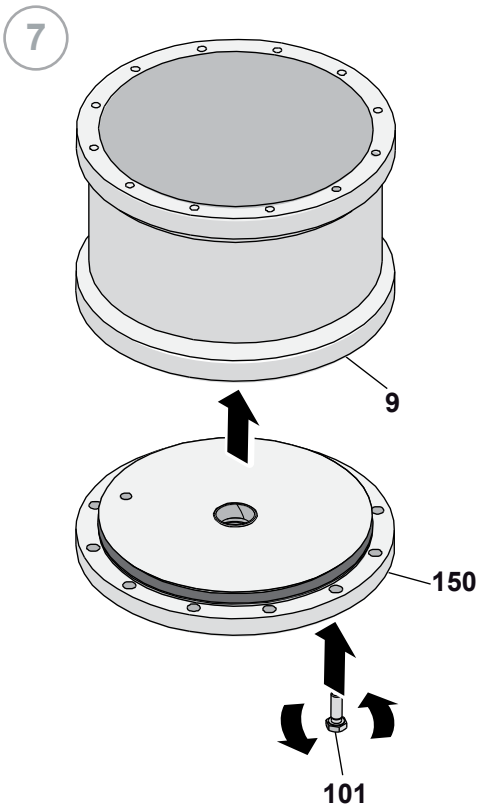
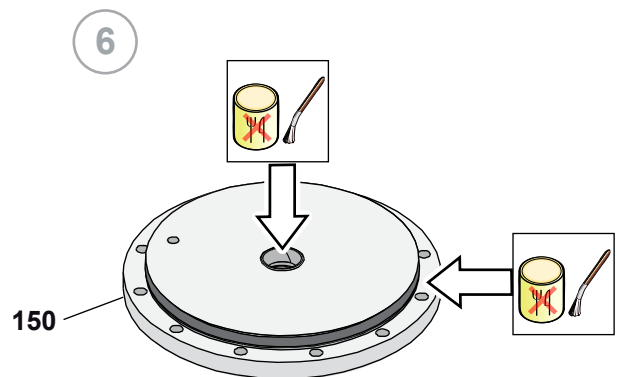
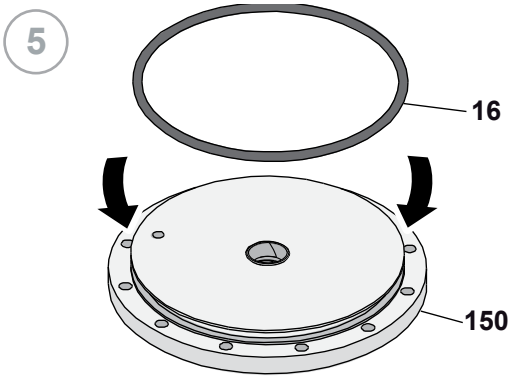

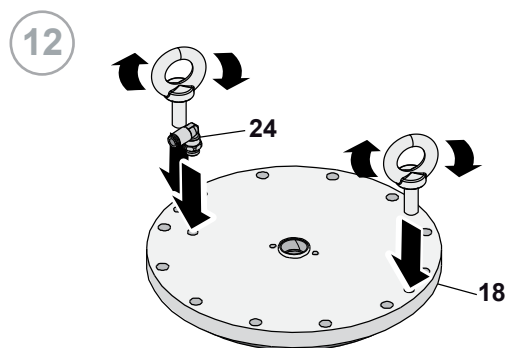
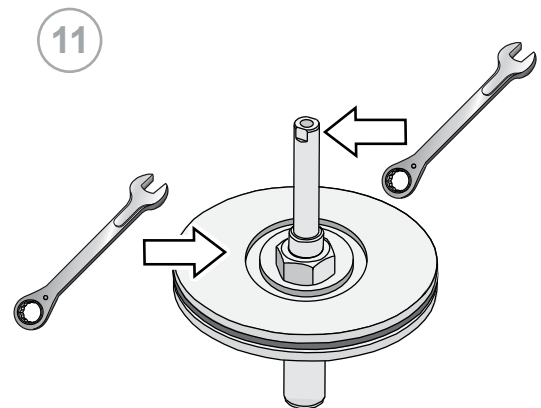
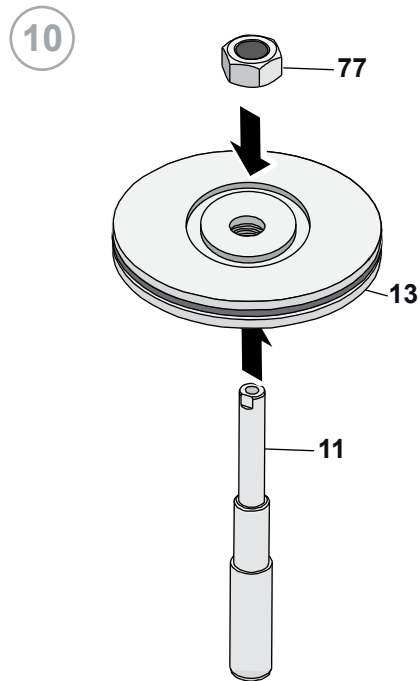

(Double acting)

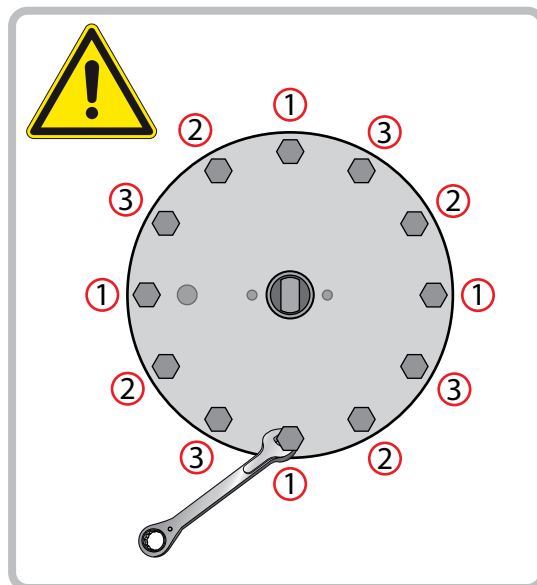
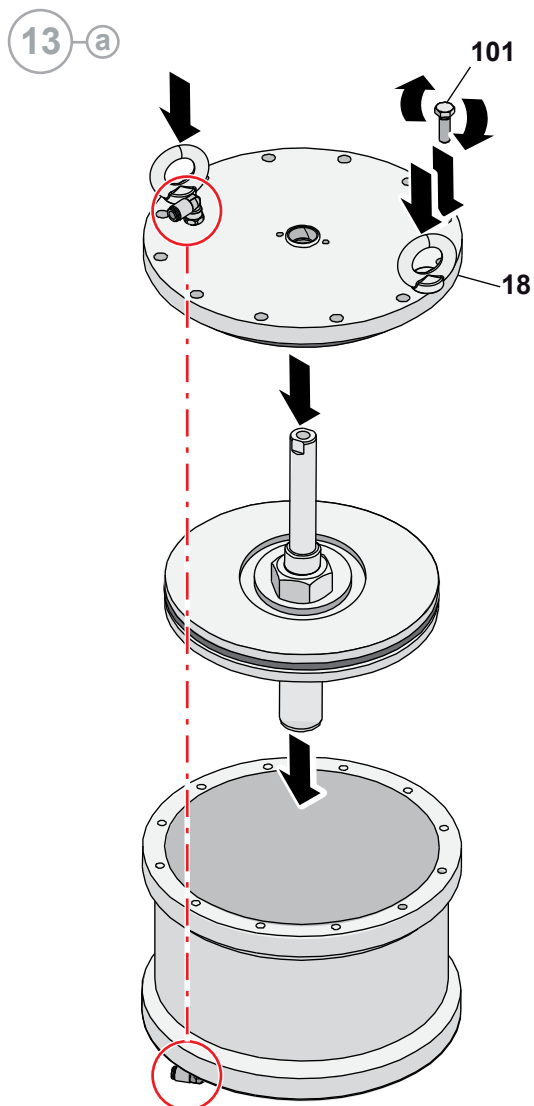

(Normally closed)

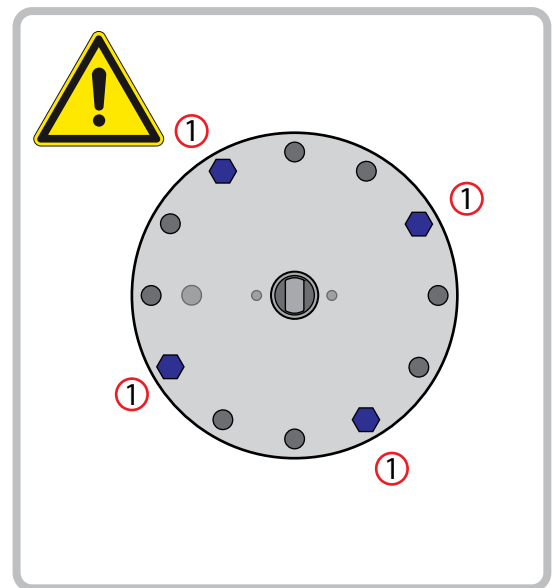
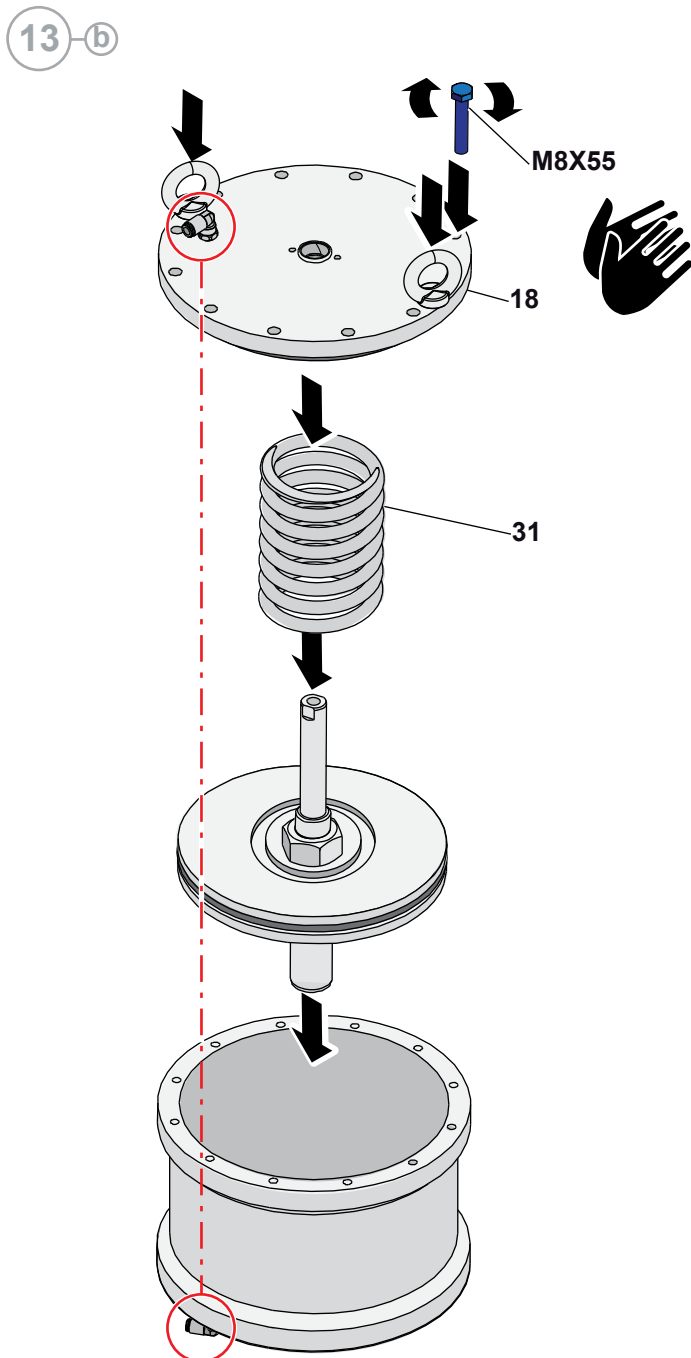

14-b

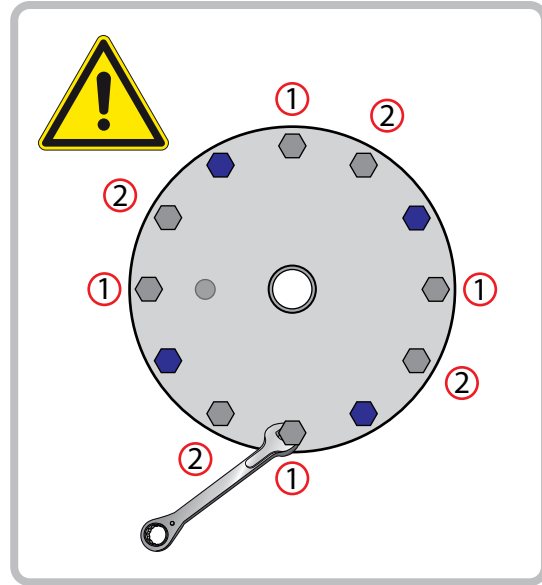
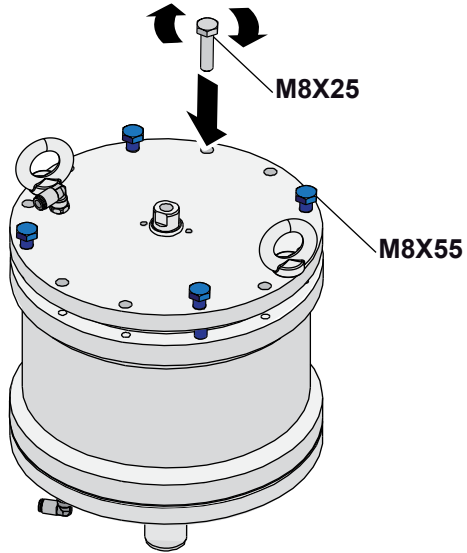

15-b

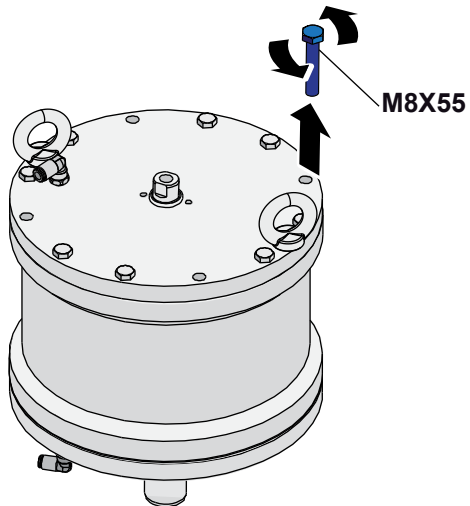

16-b

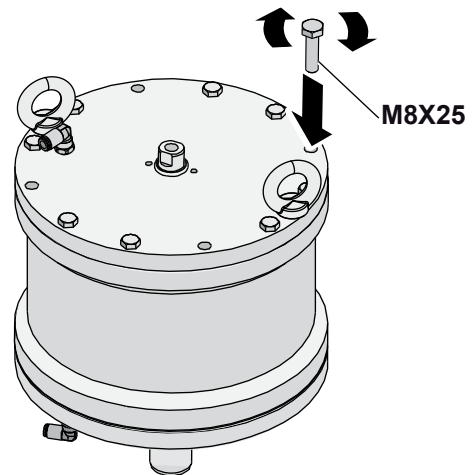

17

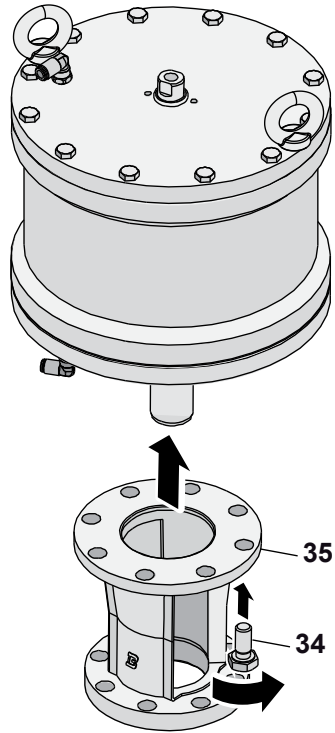

18

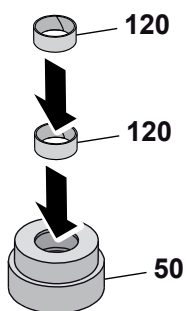

19

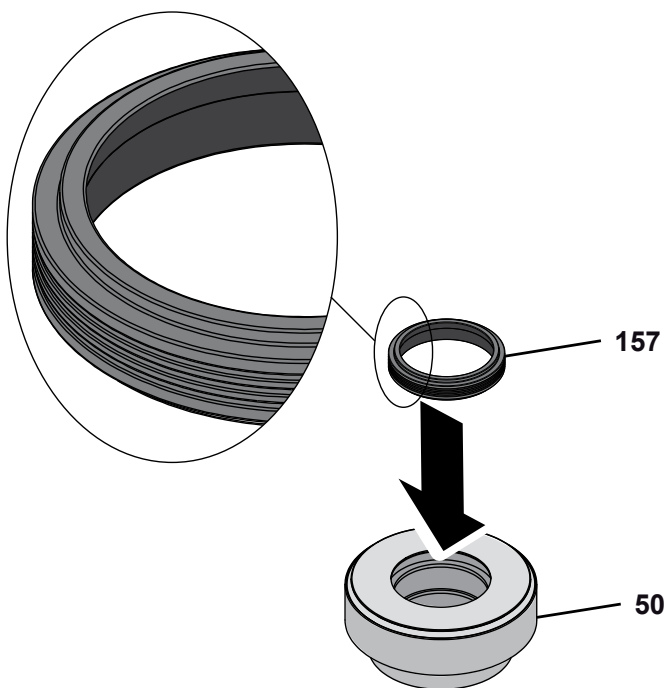
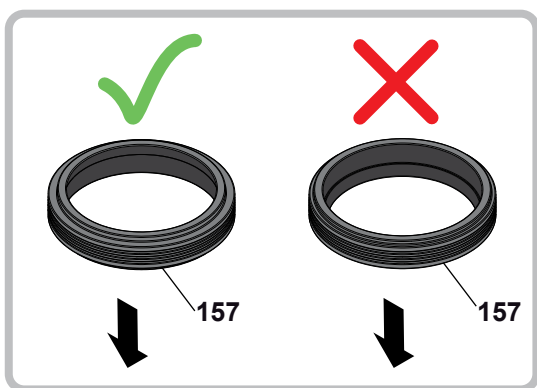

20

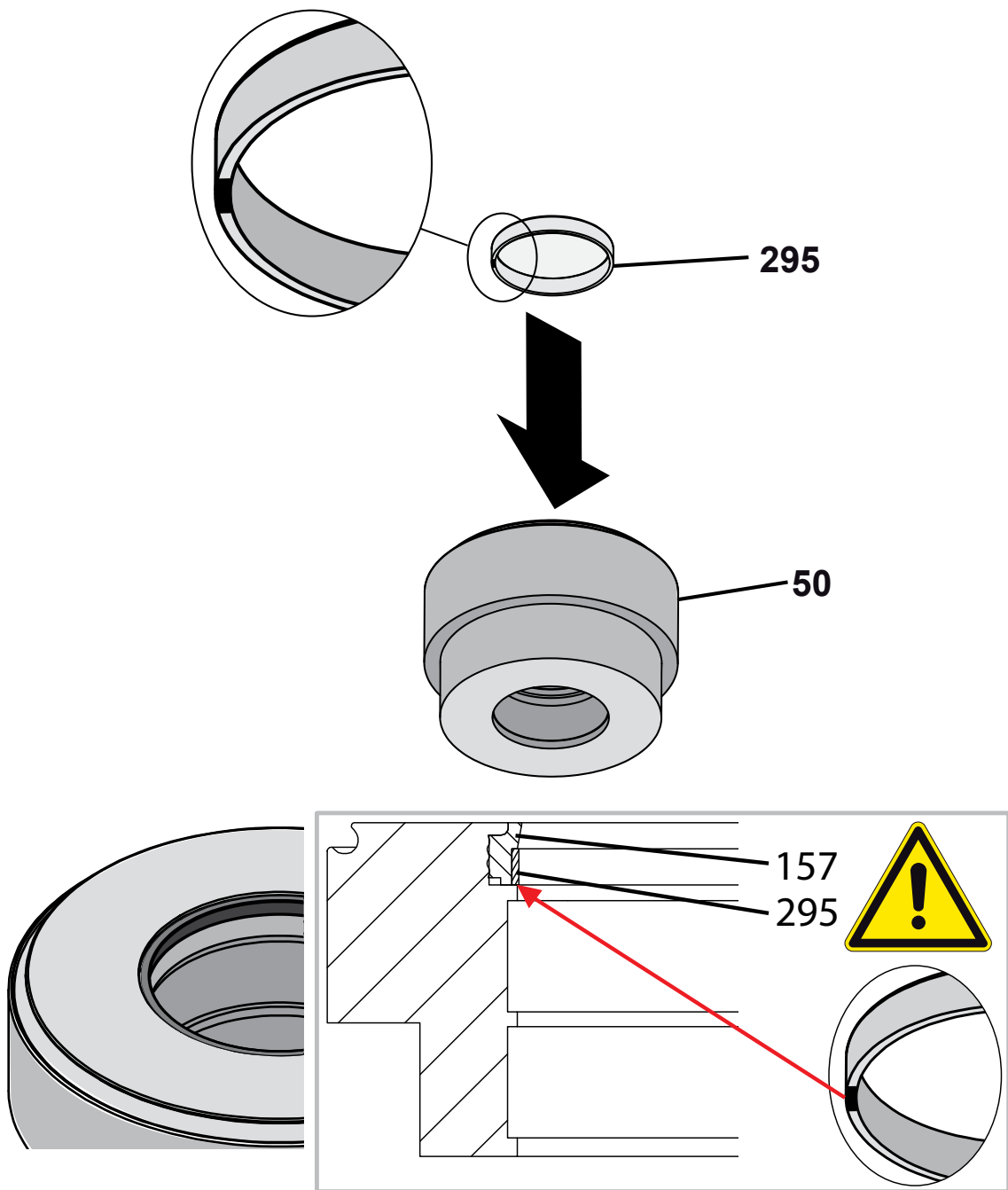

21

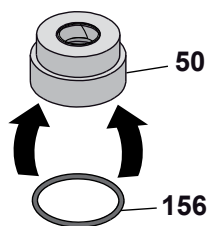

22

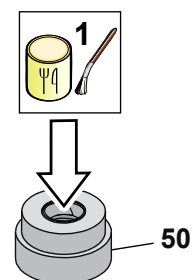

(BBYQ)

18-d

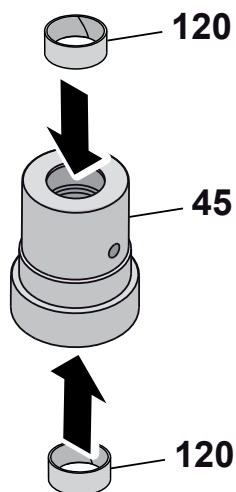

19-d

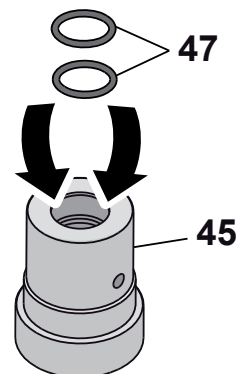

20-d

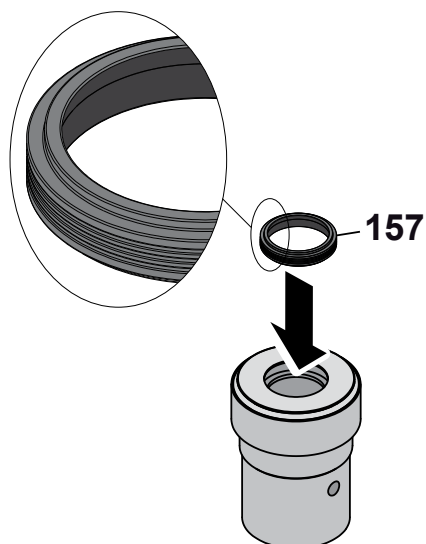
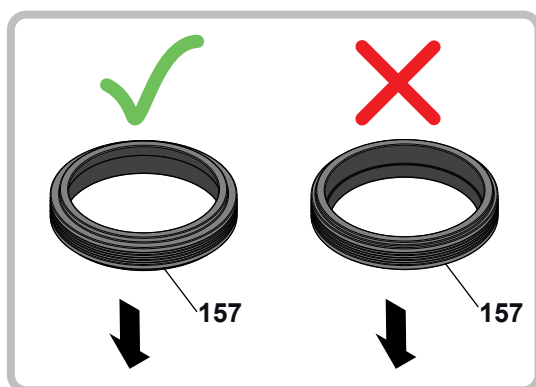

(BBYQ)

21-d

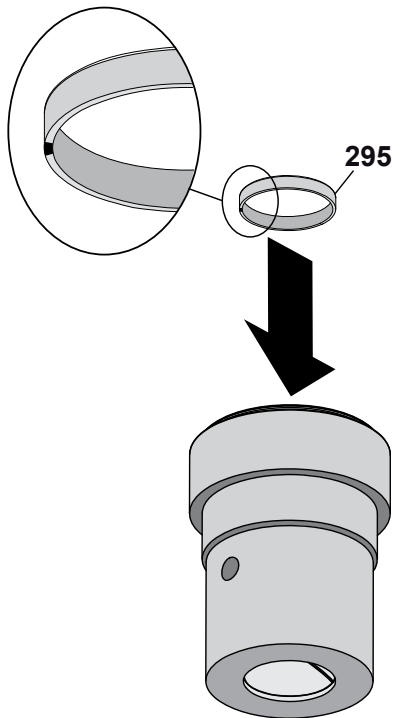

22-d

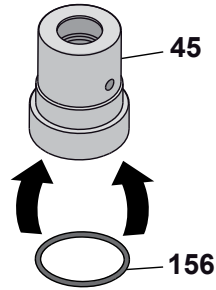

23-d

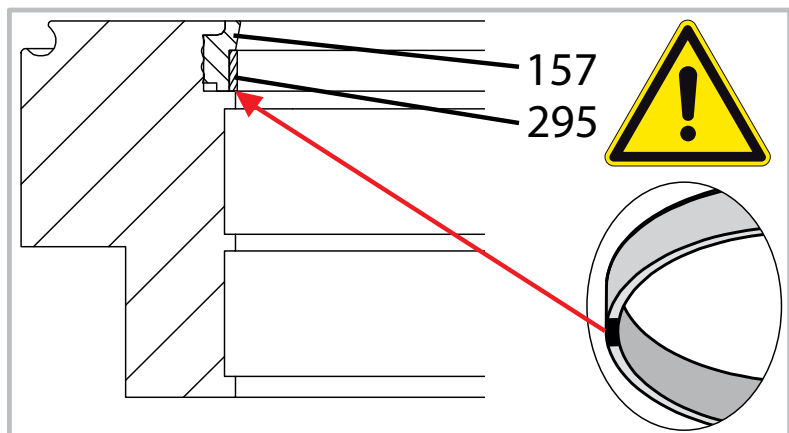
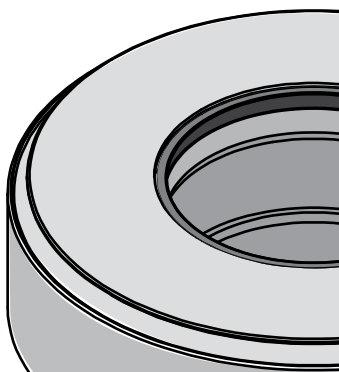
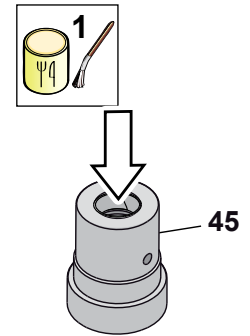

(BBYQ Special execution)

18-f

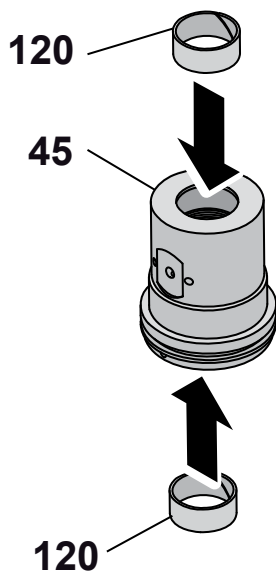

19-f

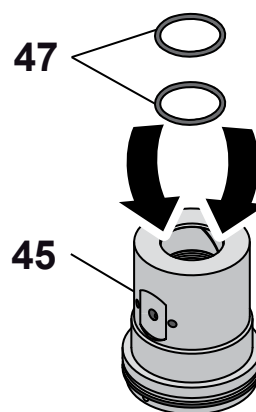

20-f

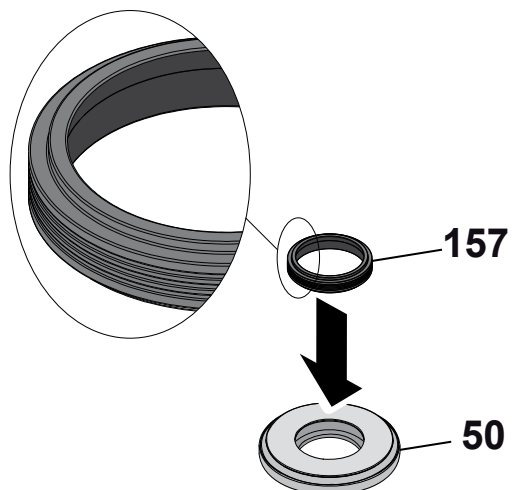
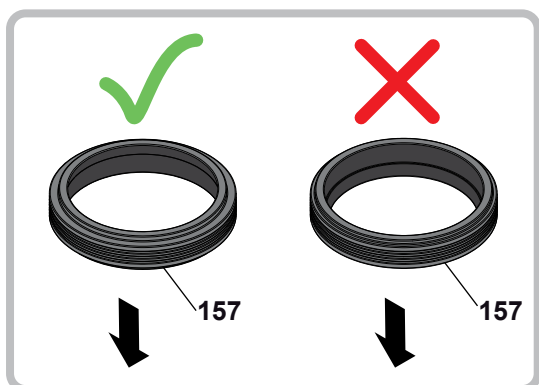

(BBYQ Special execution)

21-f

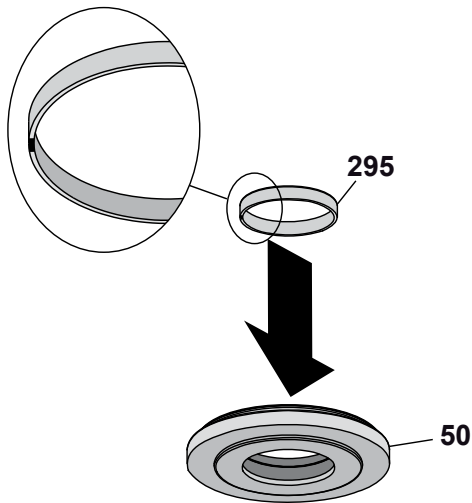

22-f

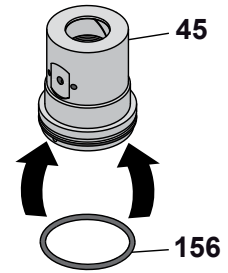

23-f

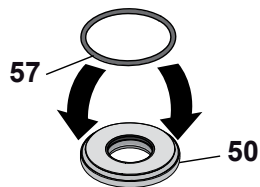

24-f

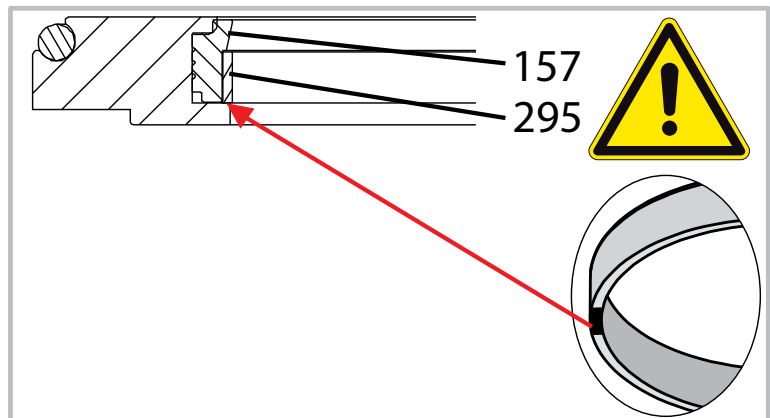
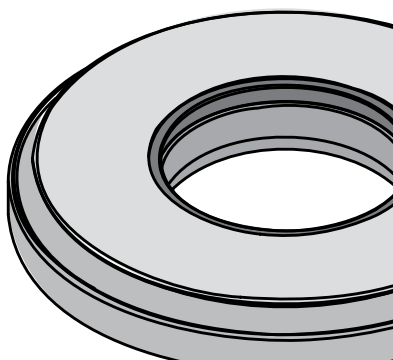
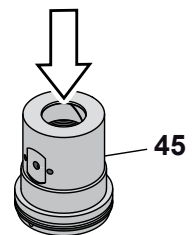
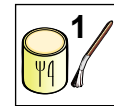

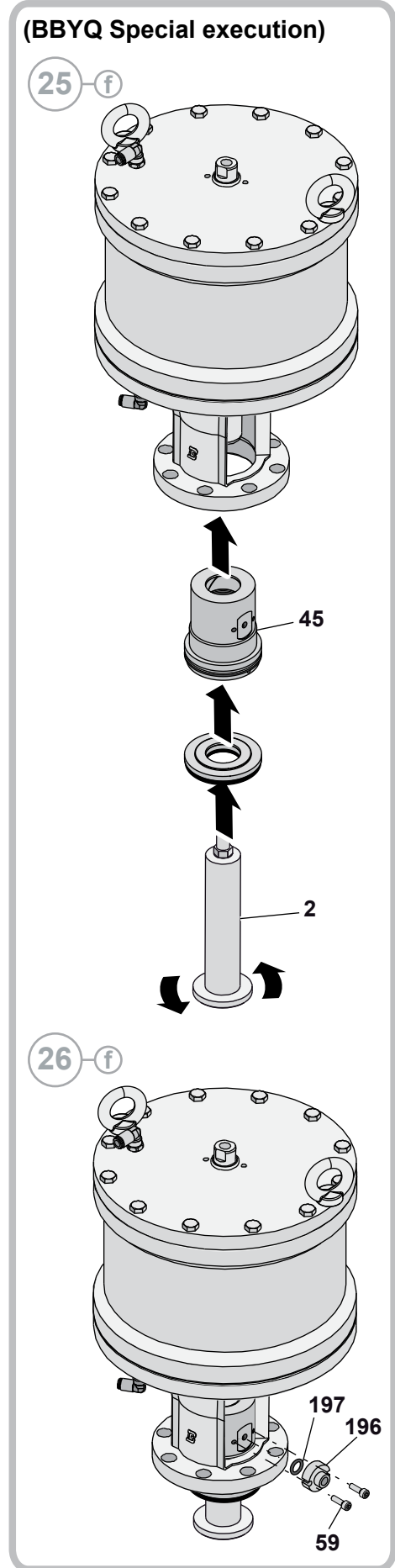
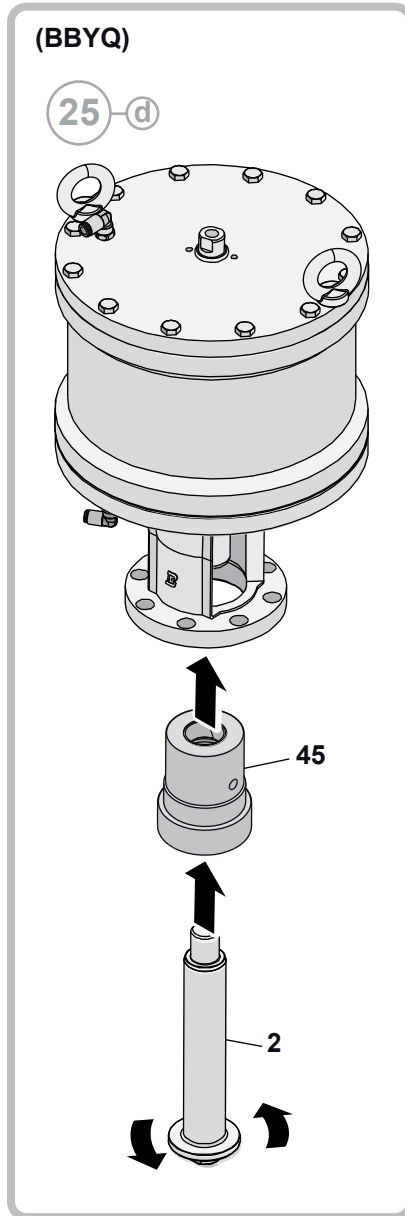
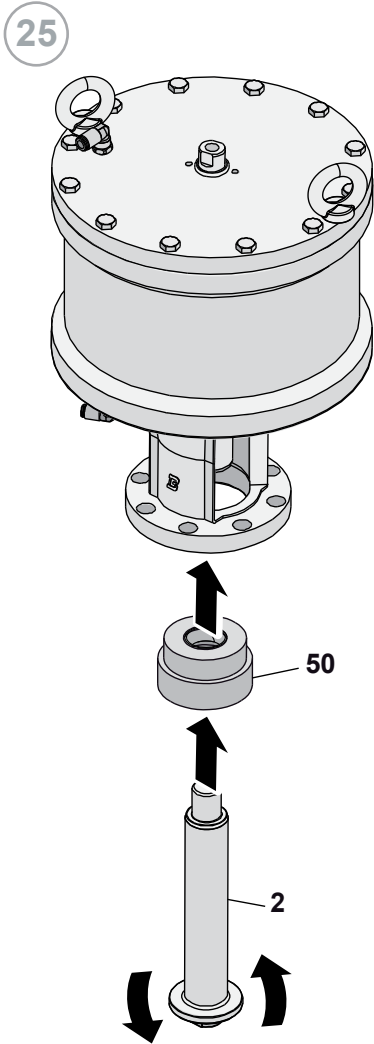

27

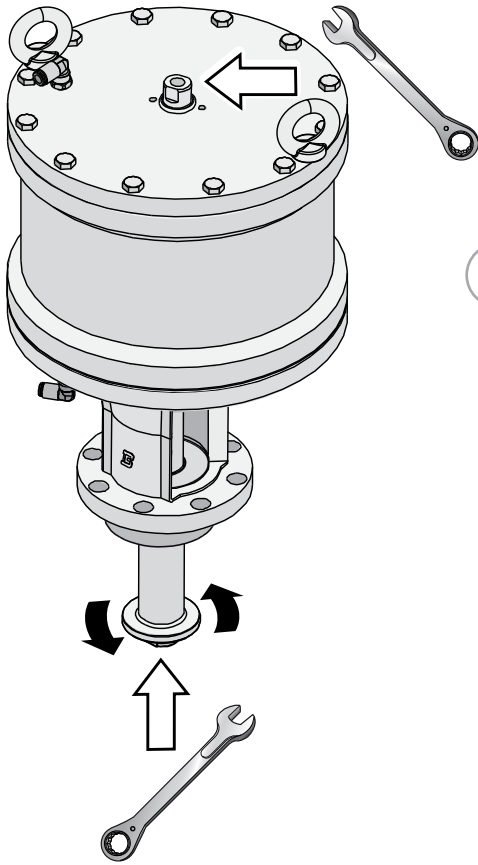

28

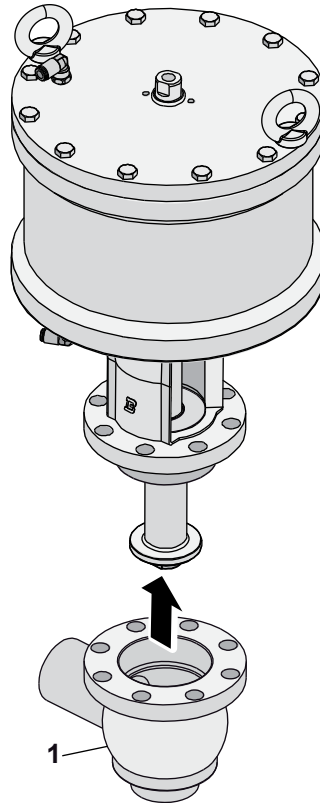

29

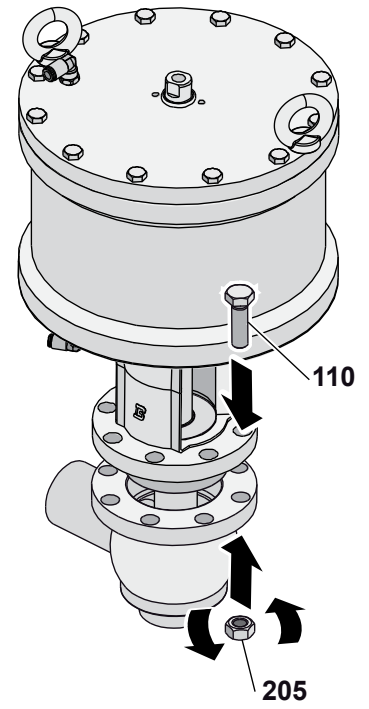

30

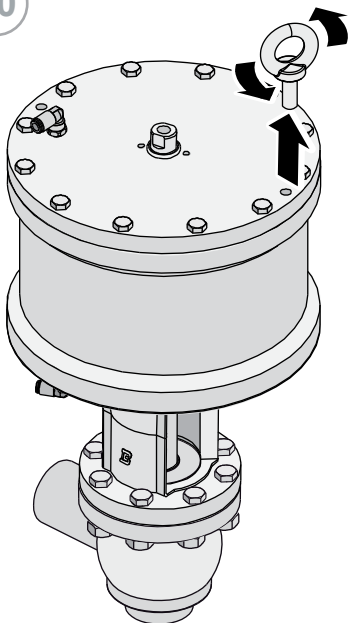

(M8)

28-a

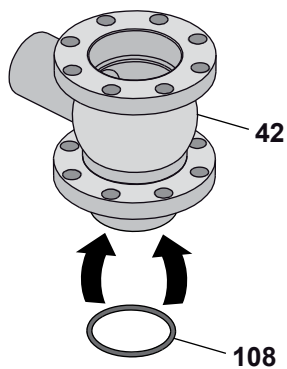

29-a

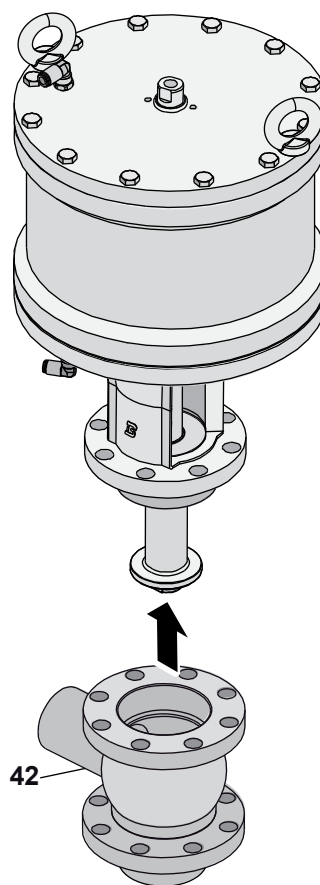

30-a

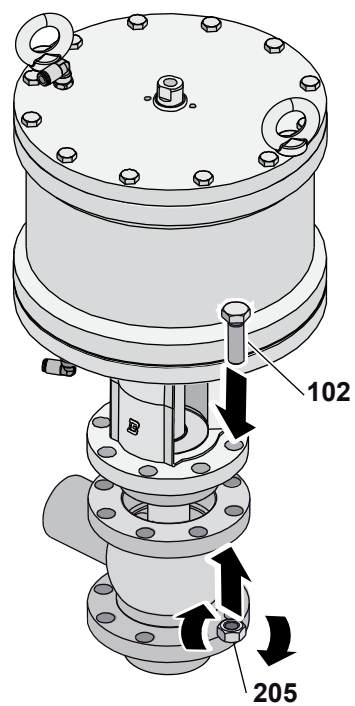

31 a

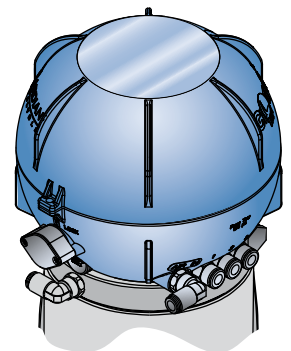
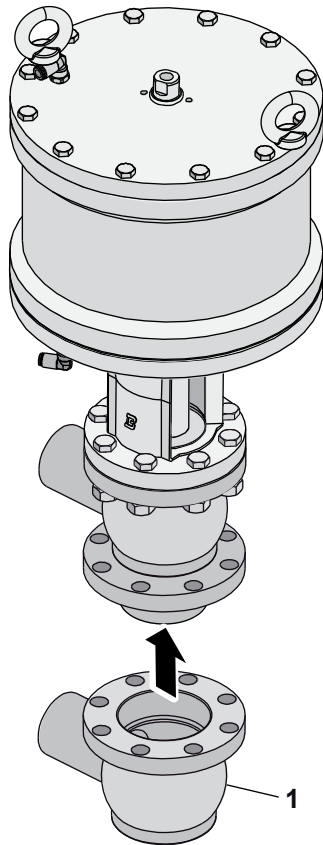

[M GIOTTO CYL.207]

10.13 Pneumatic Valve BBZQ - BBYQ cylinder 207-360 Diverter

NO.	DESCRIPTION
1	Lower body
4	Sealing ring
6	Sealing ring
9	Cylinder
10	Bush
11	Pin
12	Sealing ring
13	Piston
16	Sealing ring
17	Bush
18	Buffer
19	Sealing ring
24	Air connector
30	Double shutter
31	Spring
34	Screw
35	Assembly
42	Upper body
45	Steam barrier
47	Sealing ring
50	Gasket holder disc
57	Sealing ring
59	Screw
77	Nut
101	Screw
102	Screw
108	Sealing ring
110	Screw
120	Bush
150	Bottom stopper
156	Sealing ring
157	Sealing ring
196	Steam connection
197	Sealing ring
205	Nut
225	Sealing ring
295	Bush

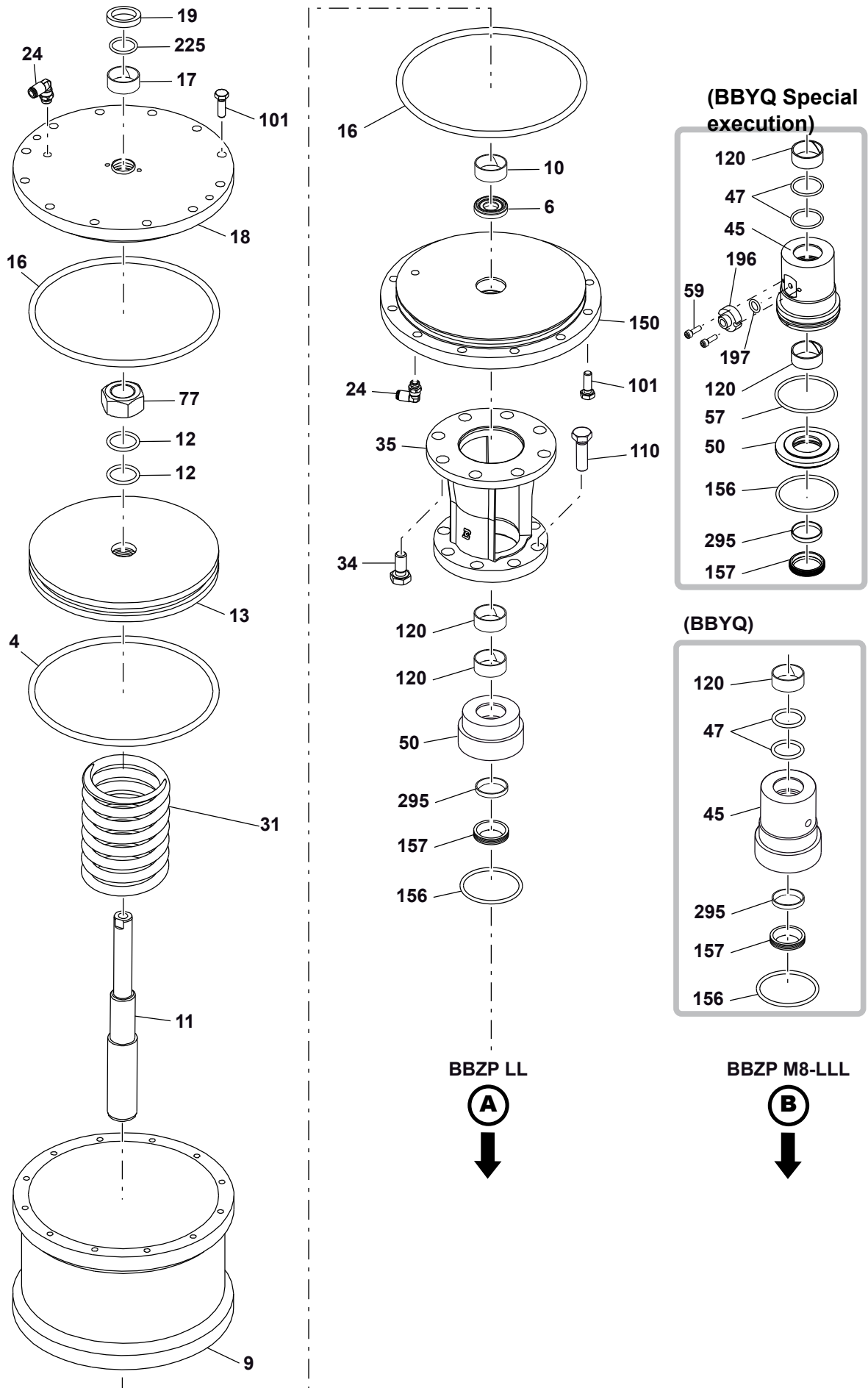

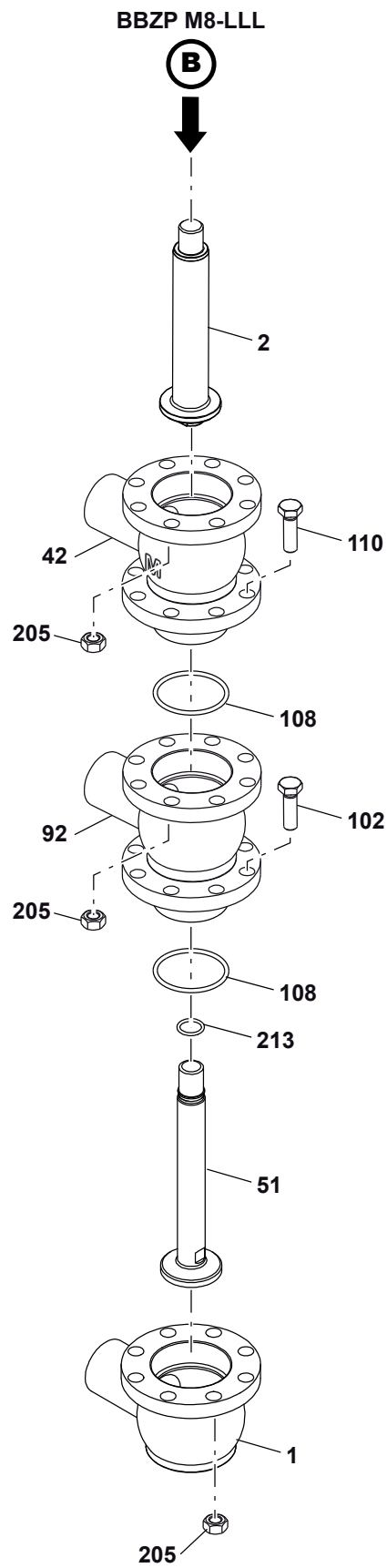
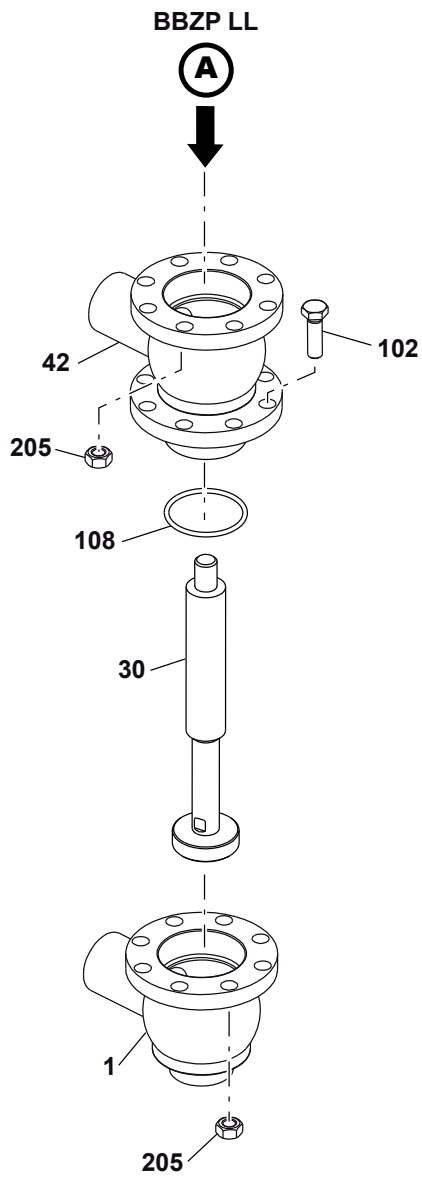

10.14 Disassembly of the BBZQ - BBYQ cylinder 207-360 Diverter

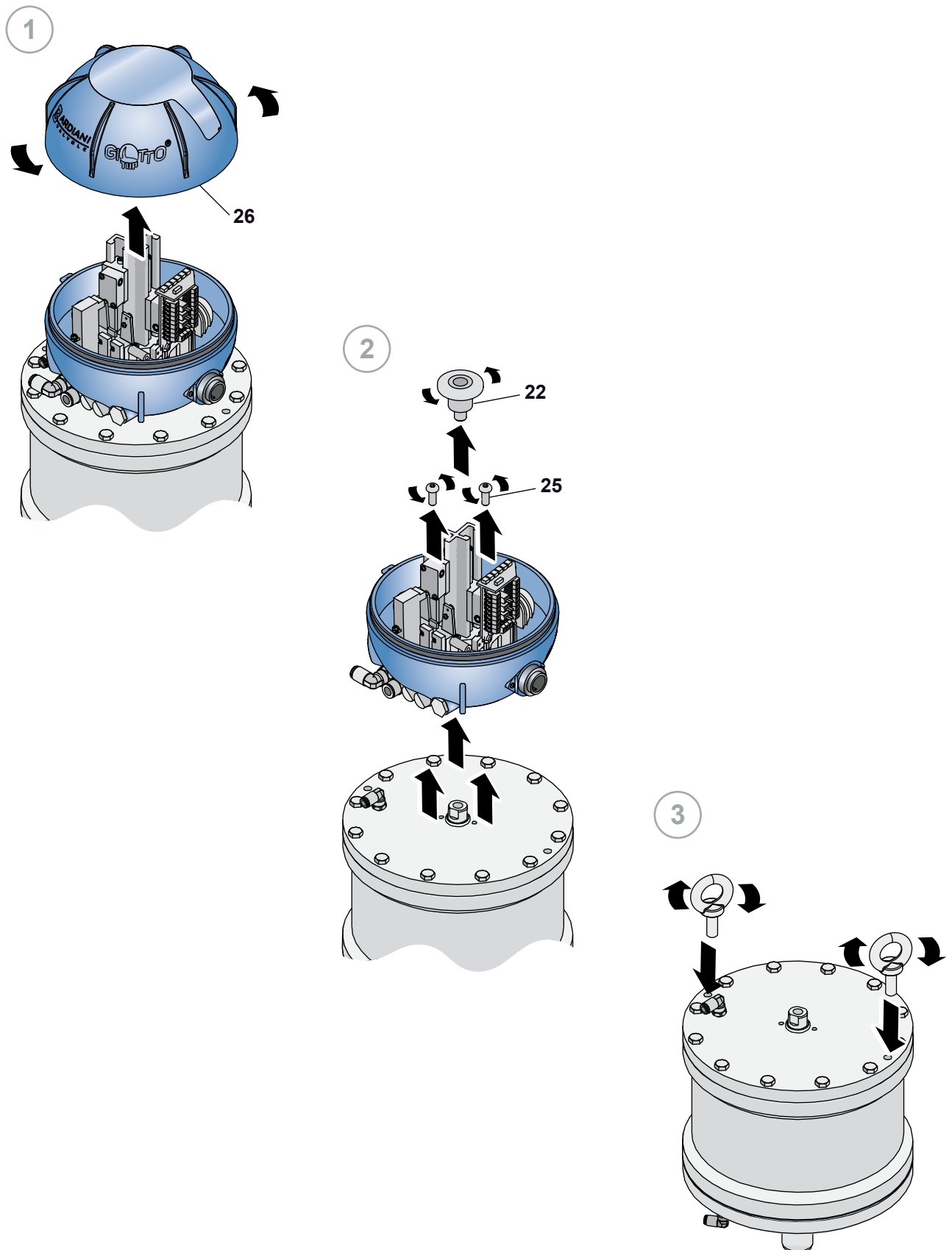

a

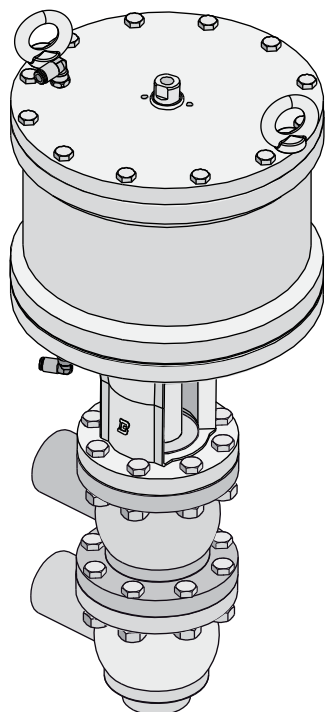

[A S BBZQ LL-207-360]

b

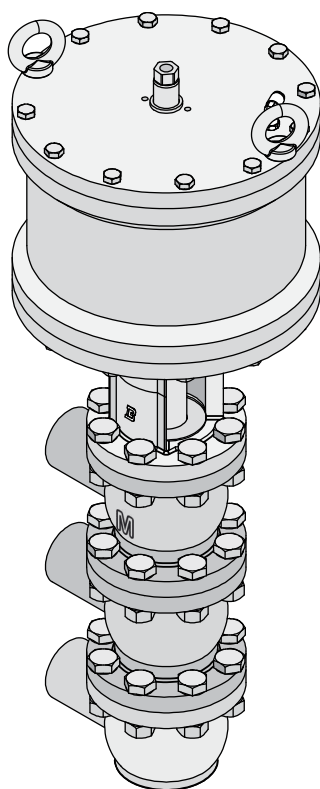

[B S BBZQ-M8-LLL-207-360]

A Dsassembly of the BBZQ - BBYQ cylinder 207-360

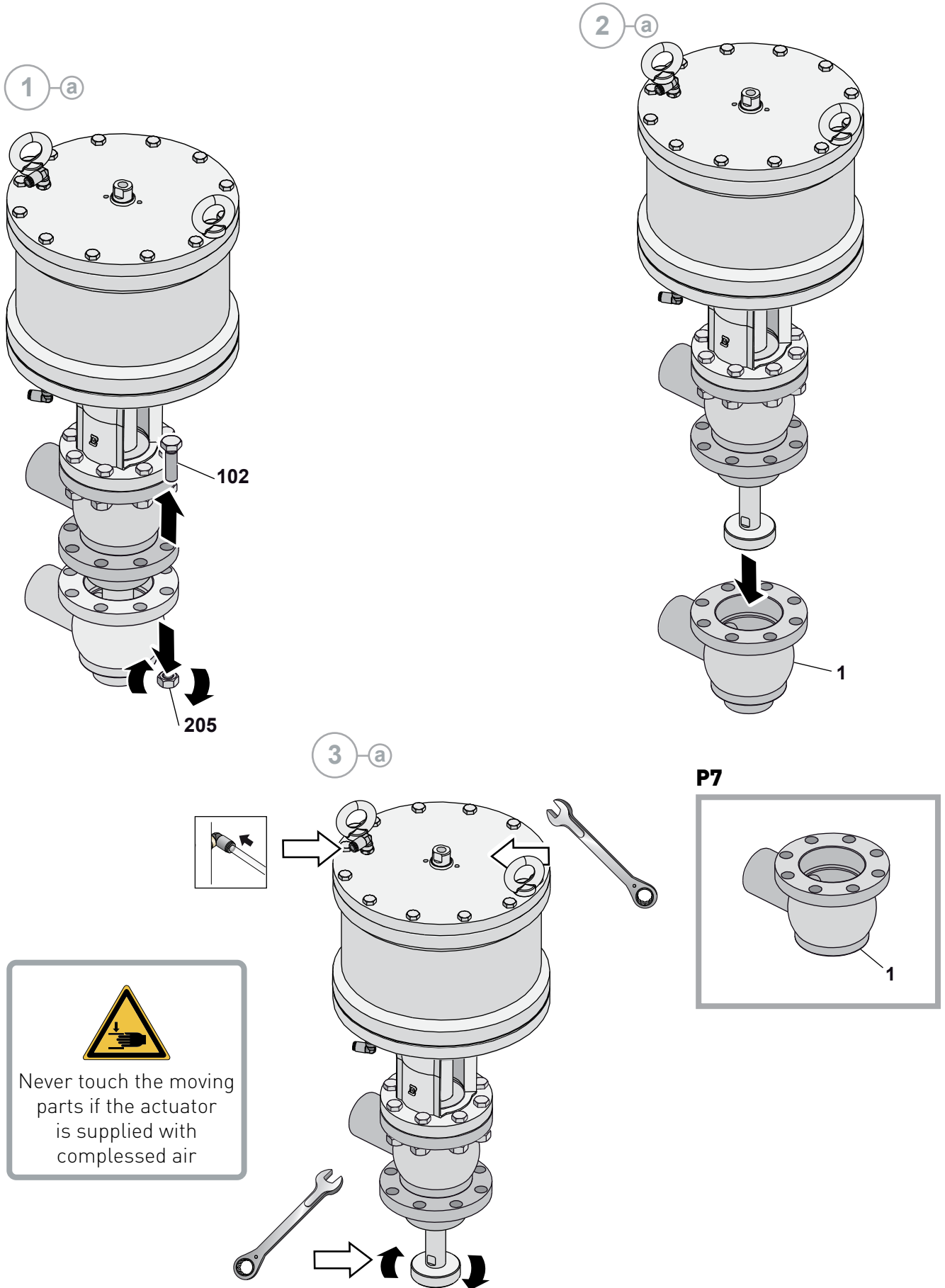

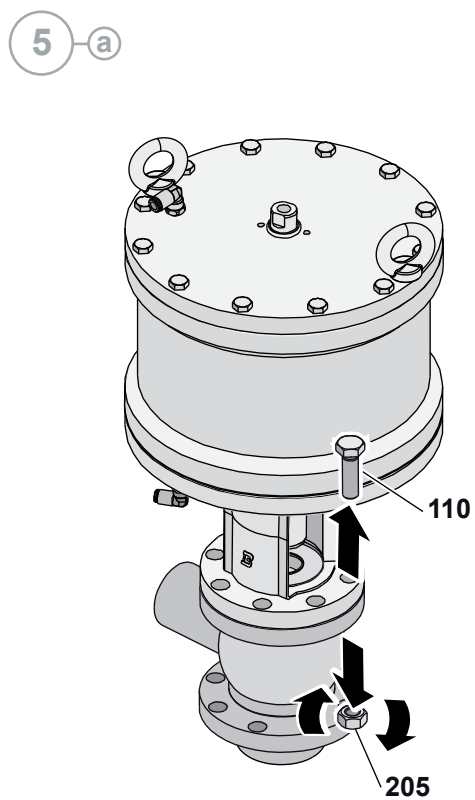
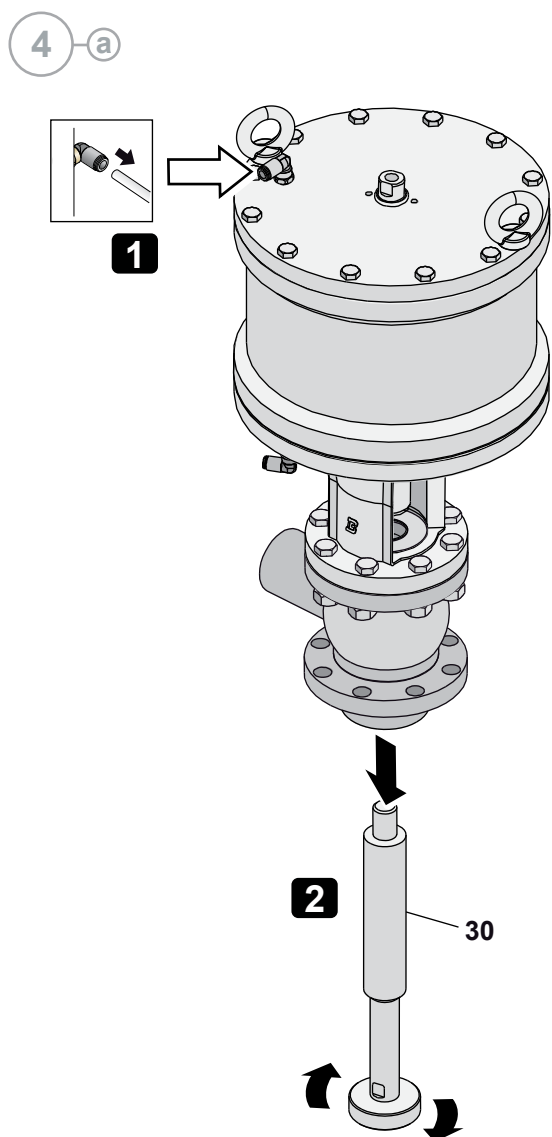

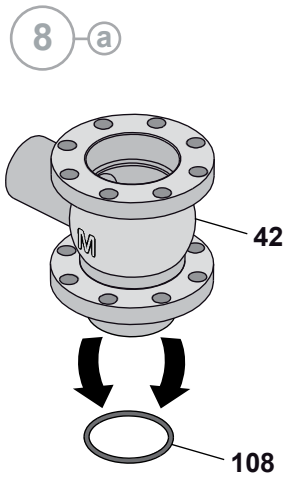
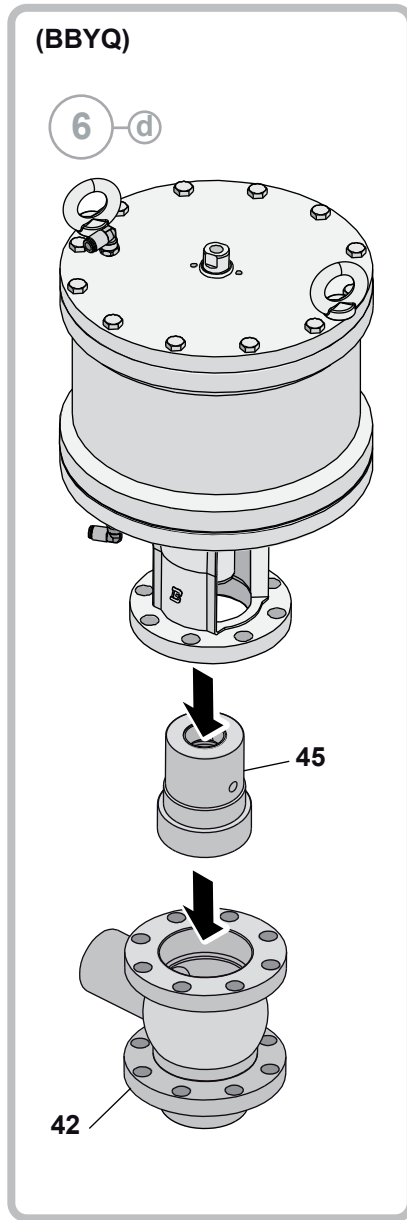
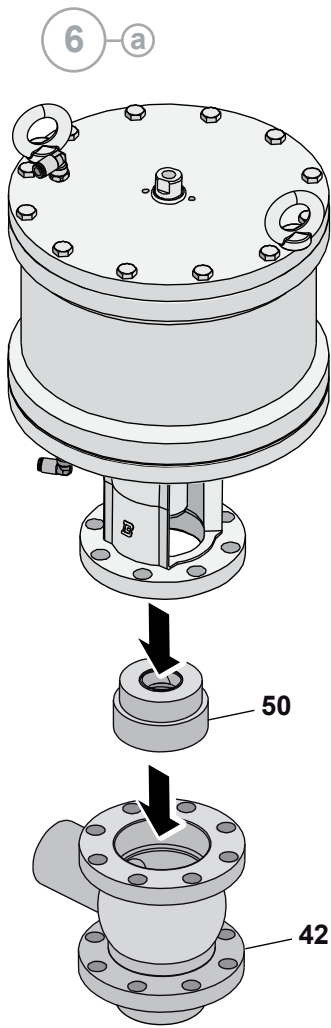

(BBYQ Special execution)

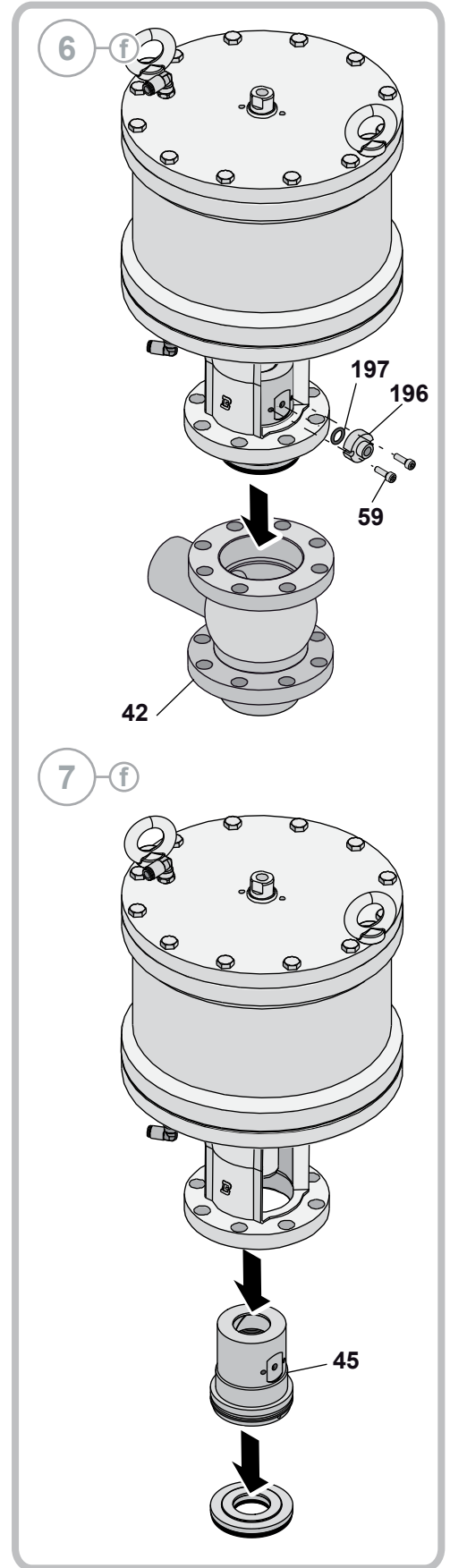

9-a

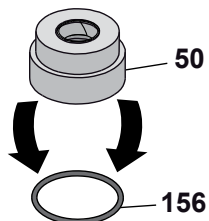

10-a

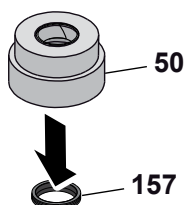

11-a

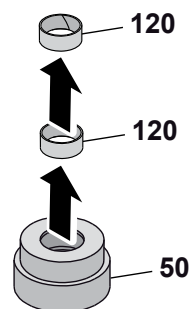

(BBYQ)

9-d

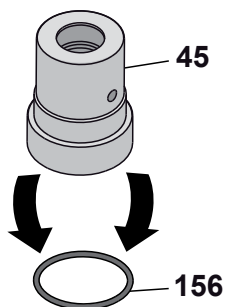

10-d

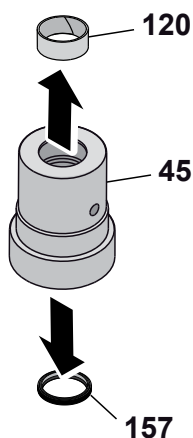

11-d

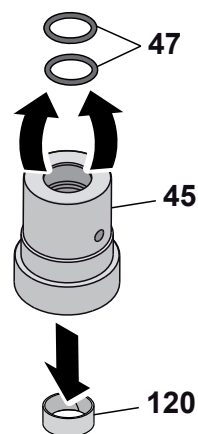

(BBYQ Special execution)

9-f

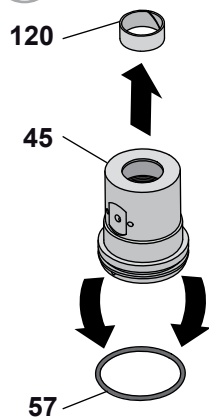

10-f

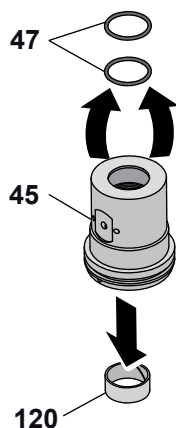

11-f

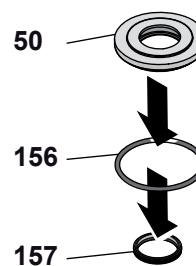

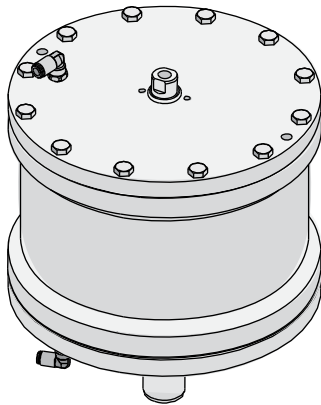

[A S CYL 207-360]

B Dsassembly of the BBZQ - M8-LLL cylinder 207-360

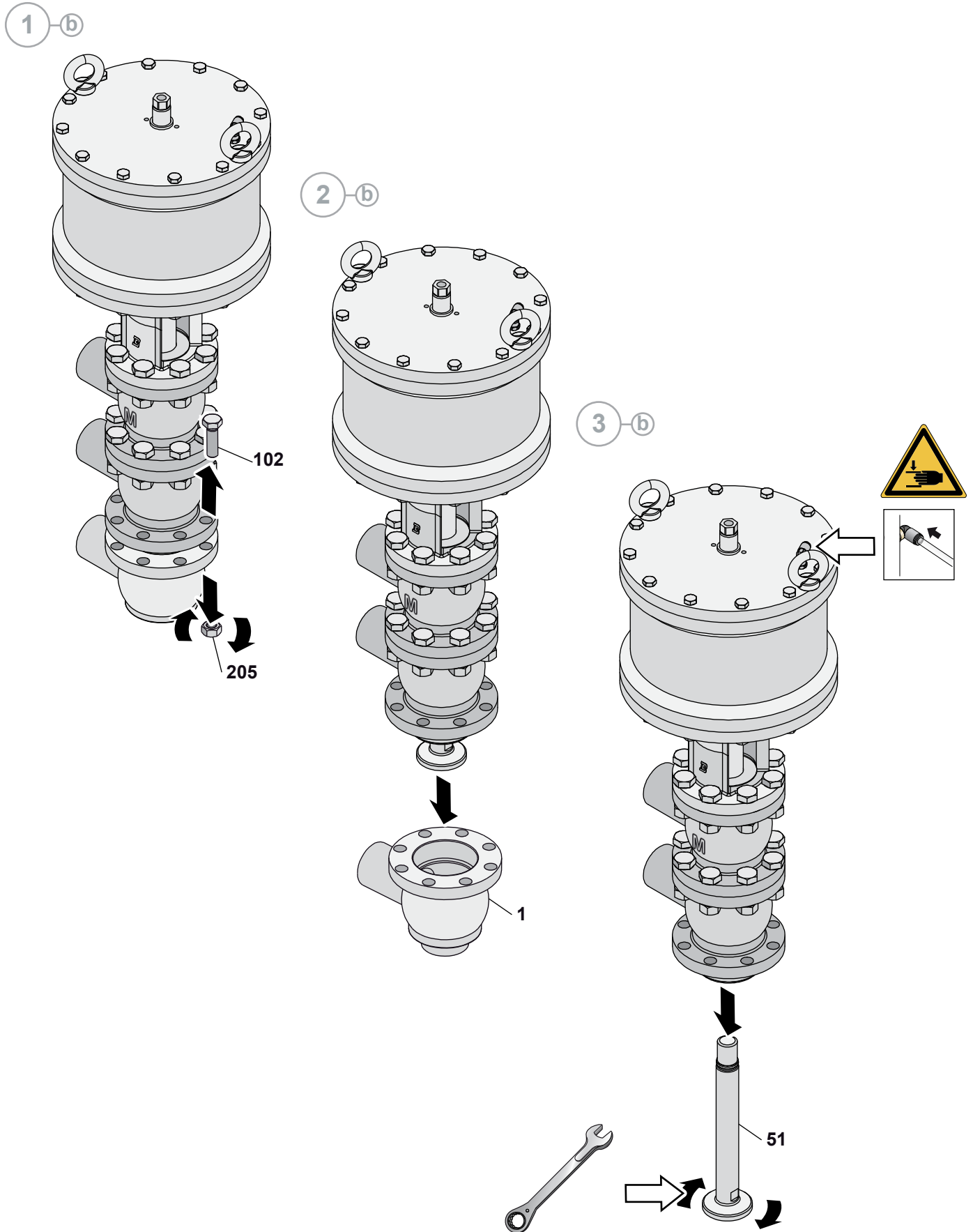

4 b

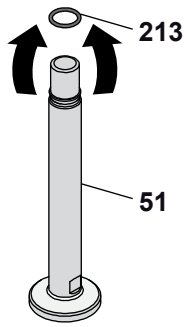

5 b

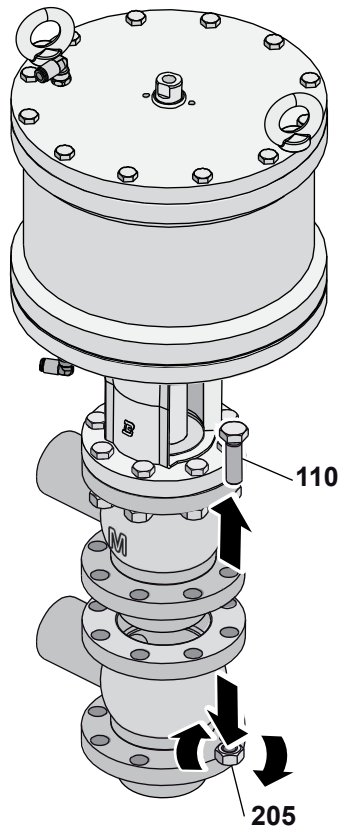

6 b

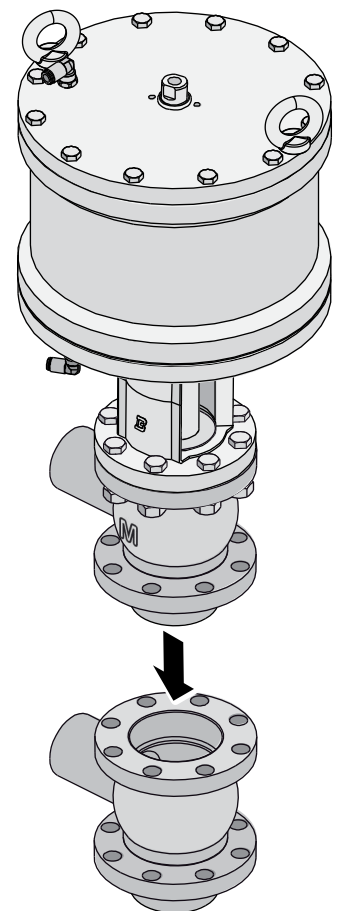

7-b

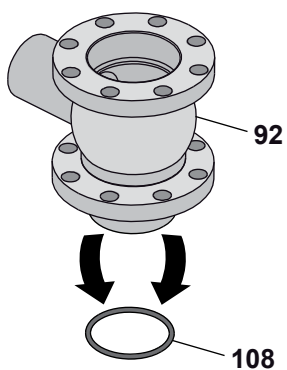

8-b

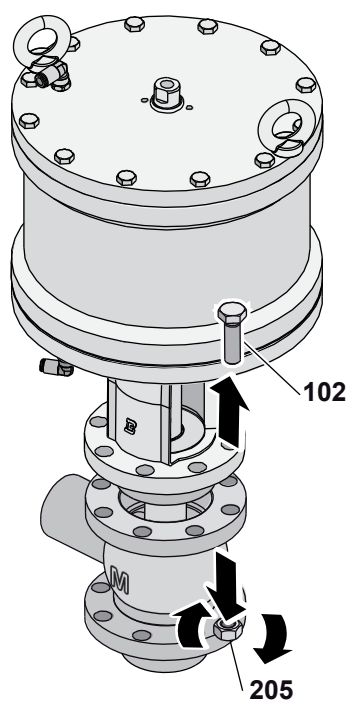

9-b

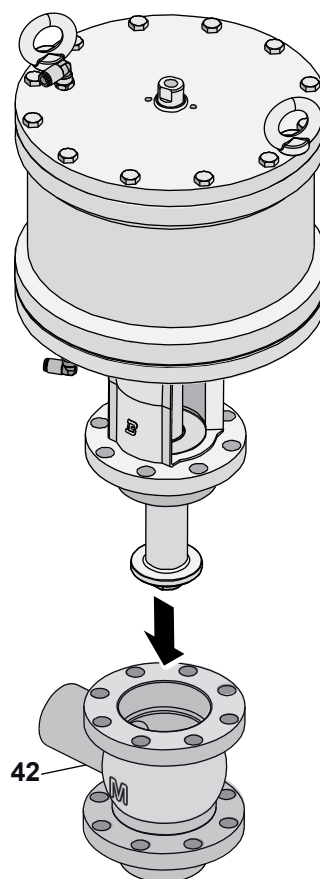

10-b

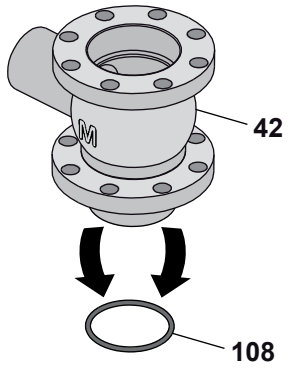

11-b

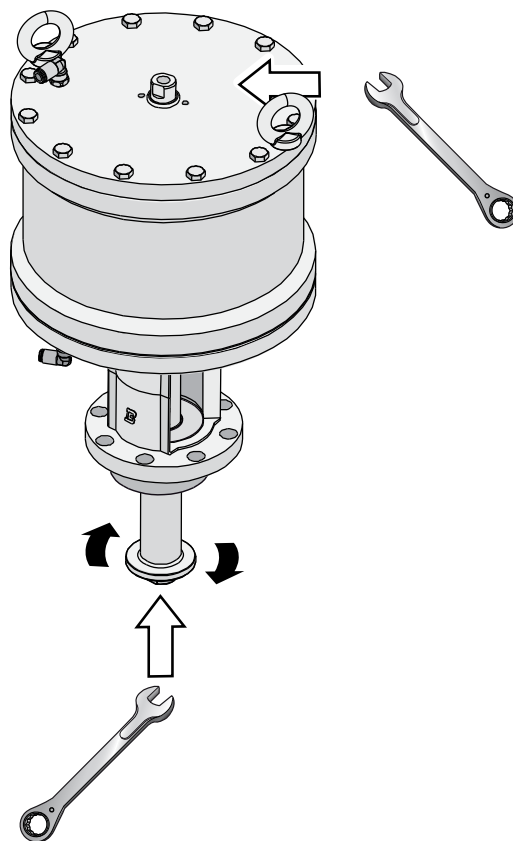

12-b

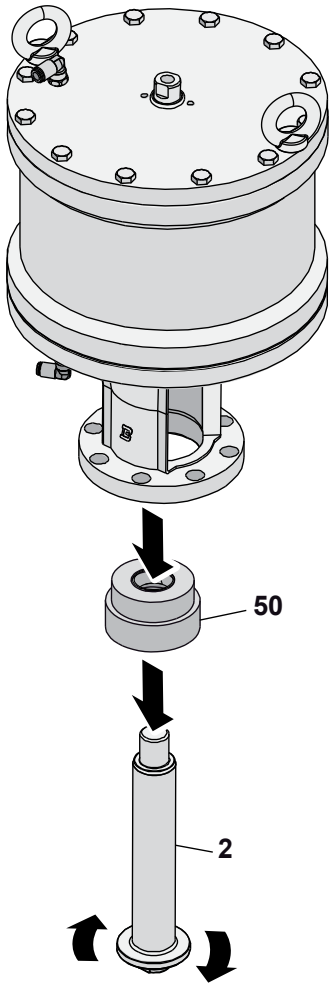

(BBYQ)

12-d

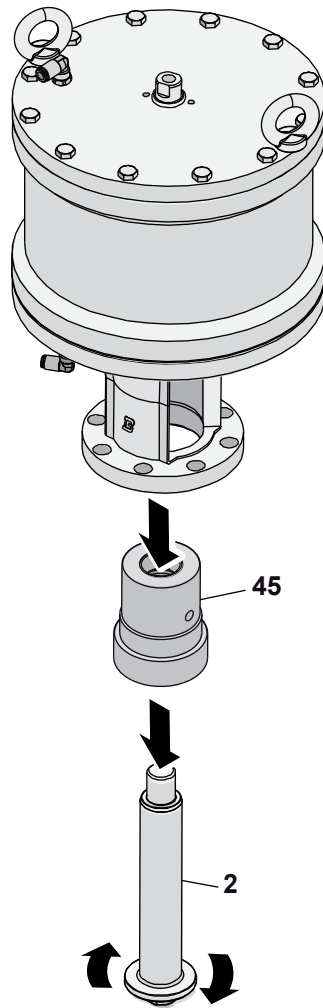

(BBYQ Special execution)

12-f

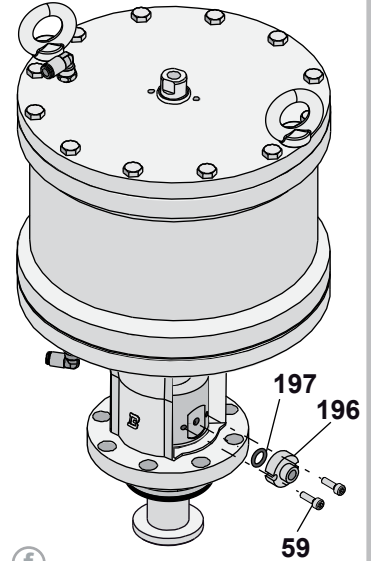

13-f

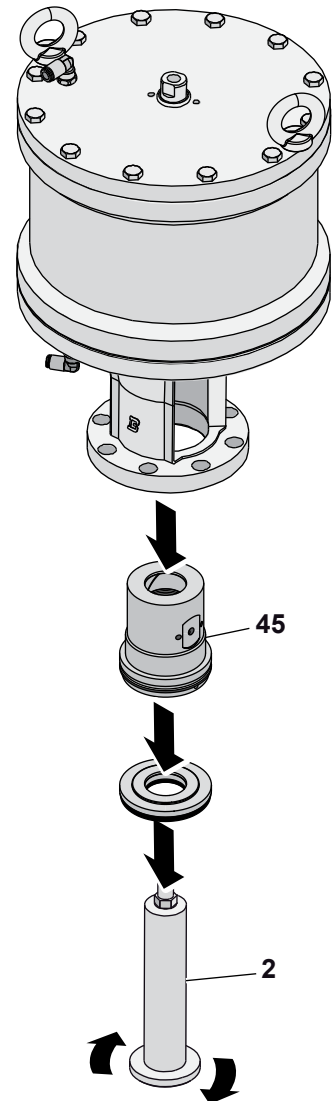

14-b

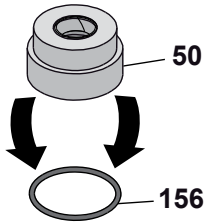

15-b

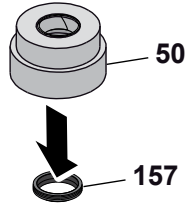

16-b

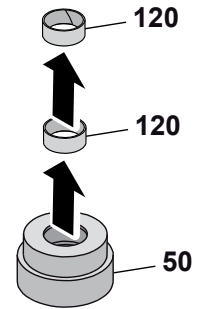

(BBYQ)

14-d

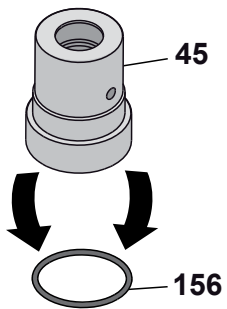

15-d

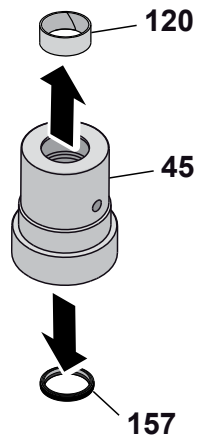

16-d

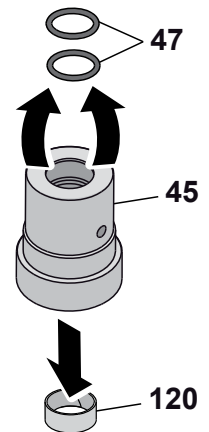

(BBYQ Special execution)

14-f

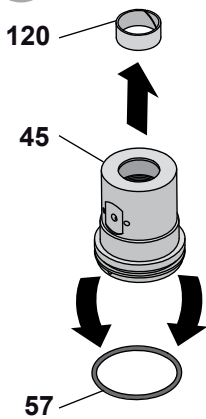

15-f

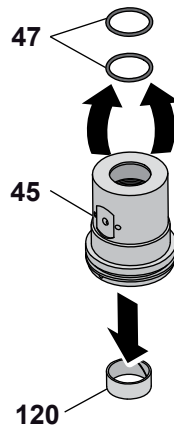

16-f

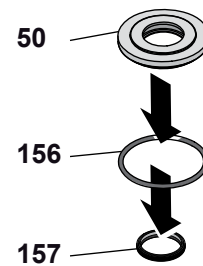

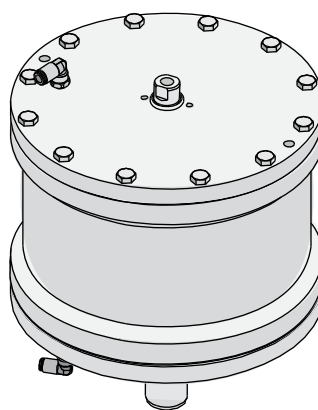
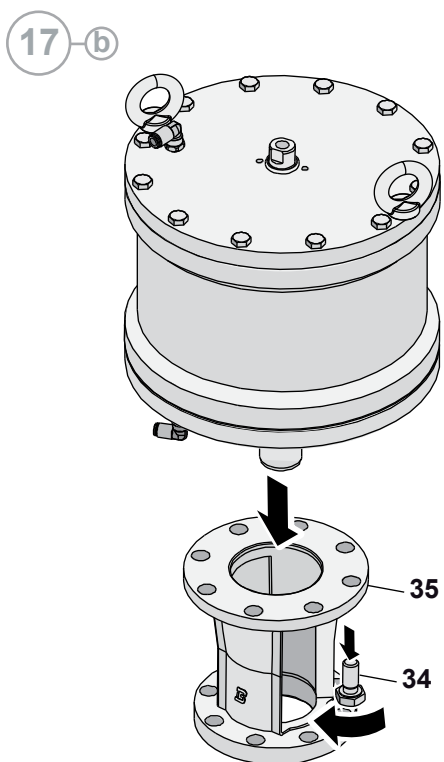

[A S CYL 207-360]

10.15 Assembly of the BBZQ - BBYQ cylinder 207-360 Diverter

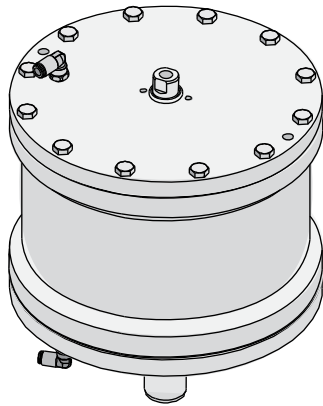

[A M CYL 207-360]

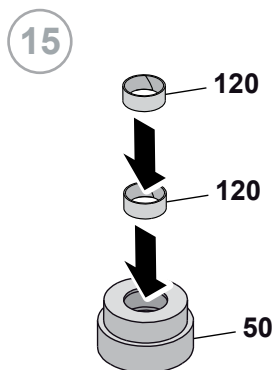

16

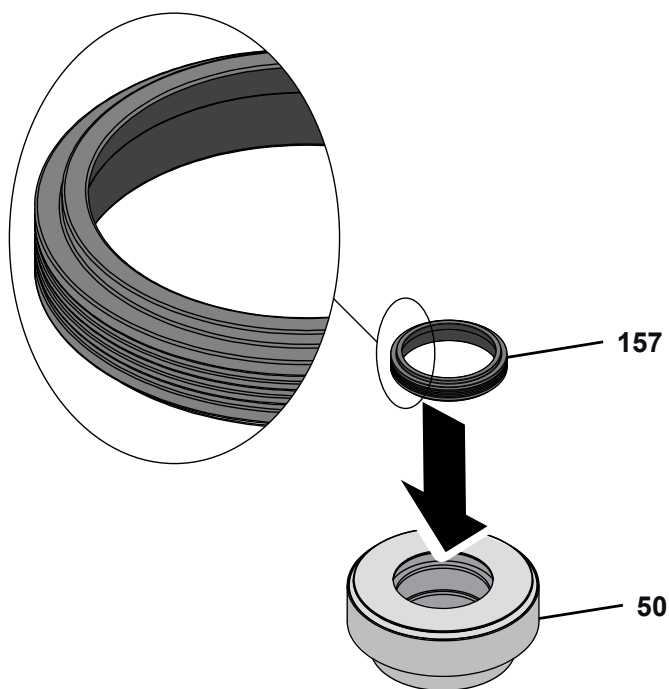
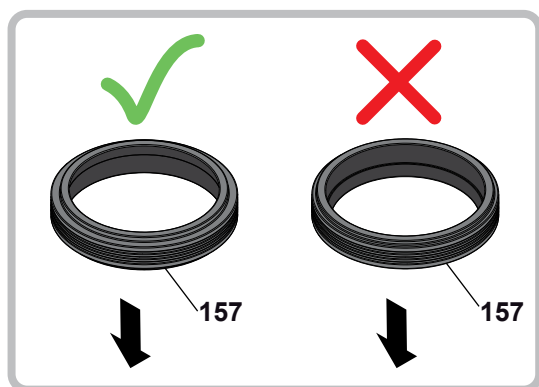

17

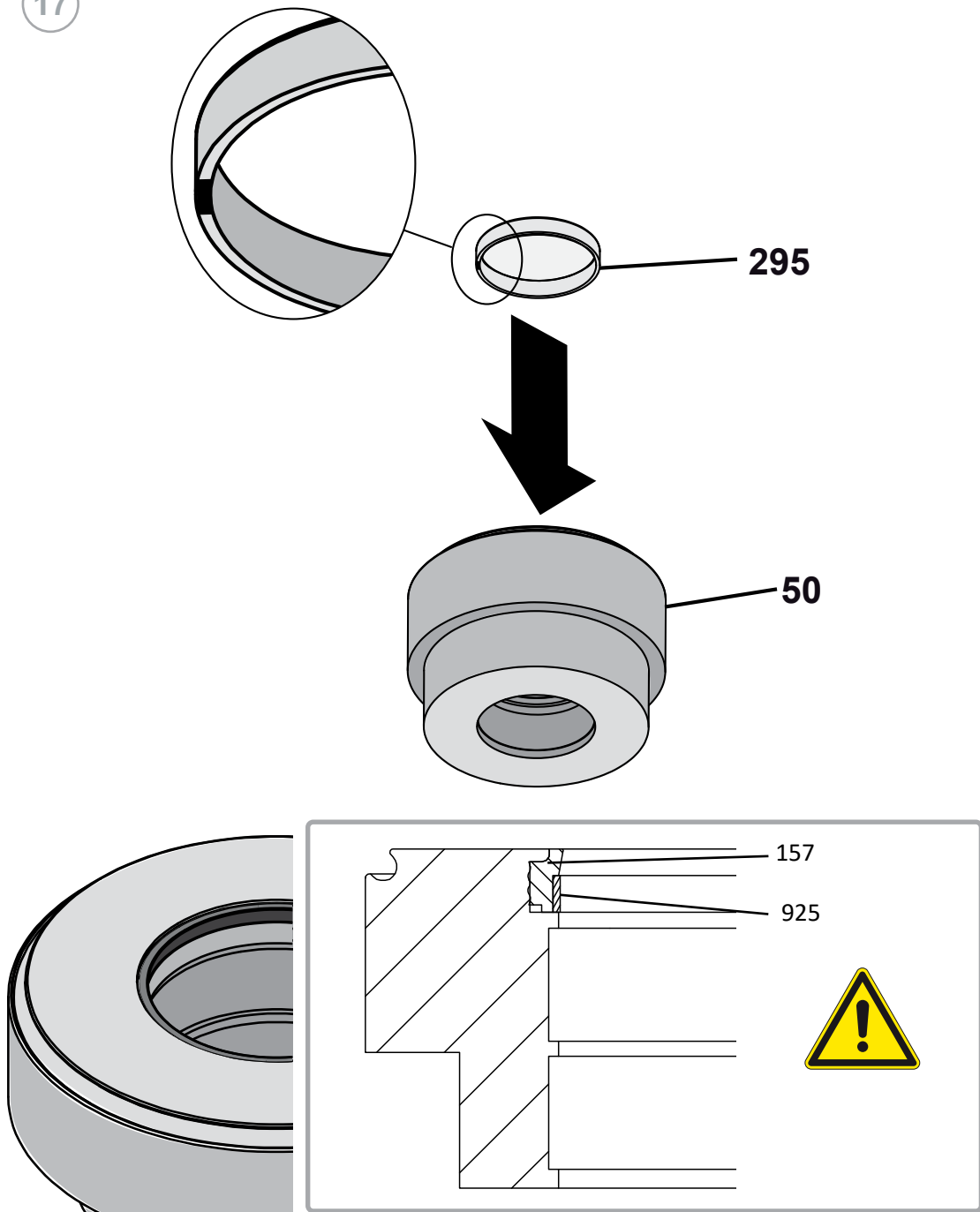

18

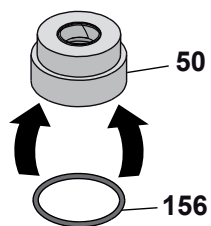

19

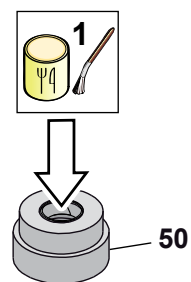

(BBYQ)

15-d

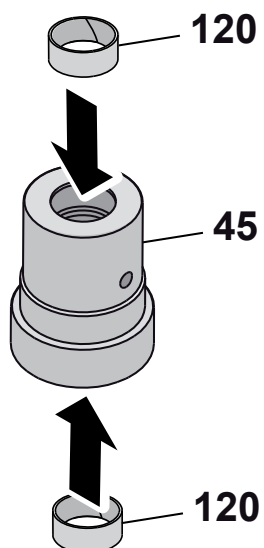

16-d

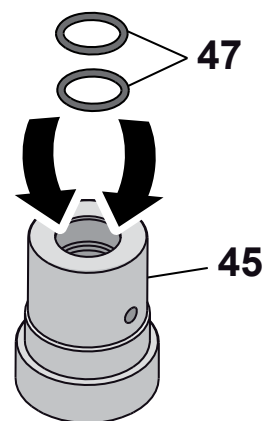

17-d

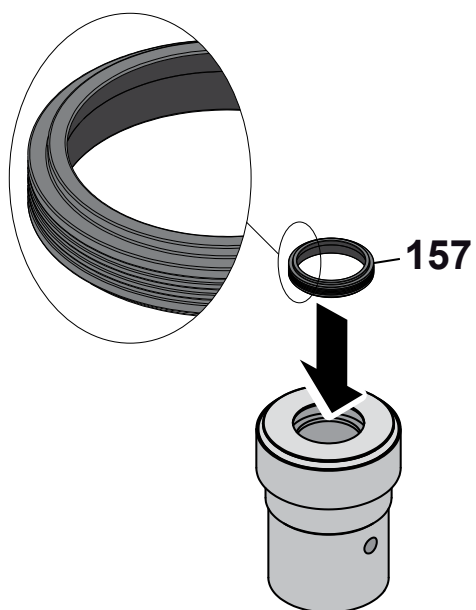
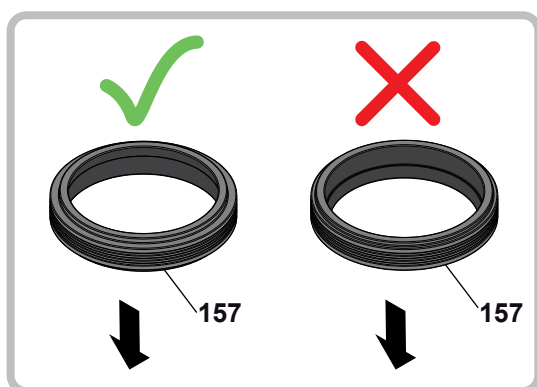

(BBYQ)

19-d

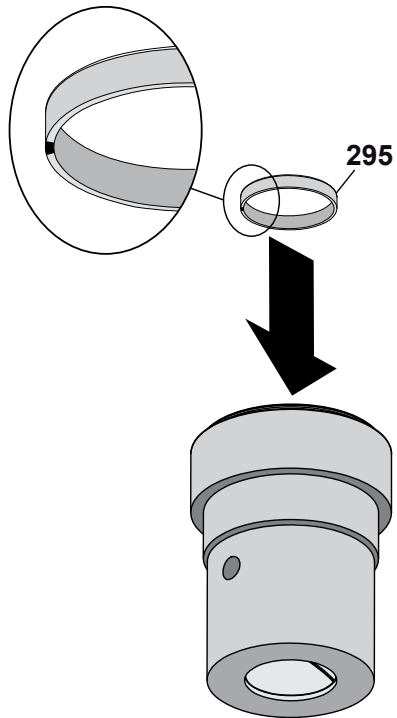

20-d

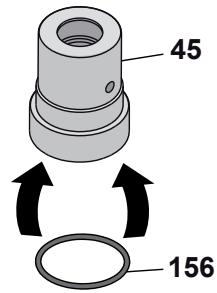

21-d

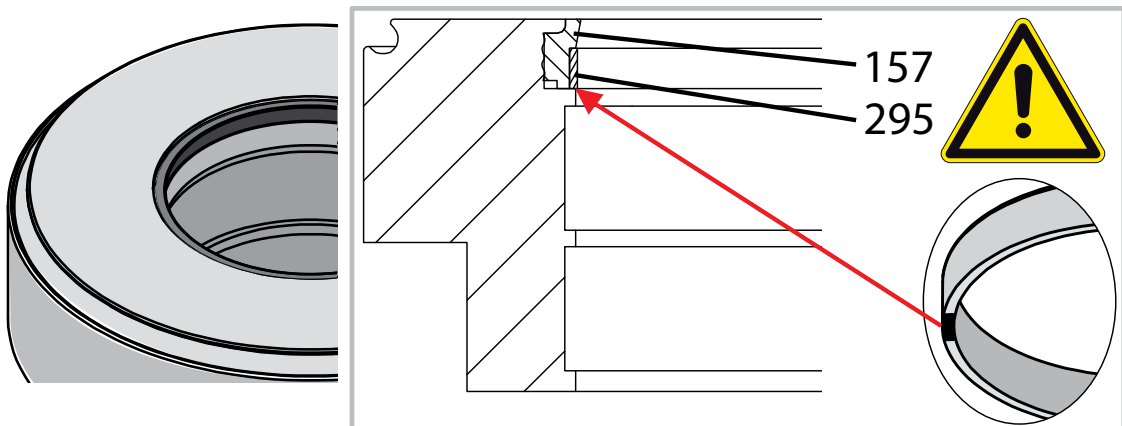
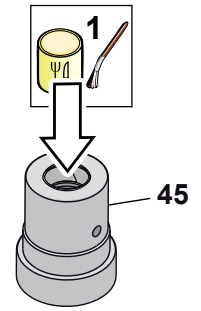

(BBYQ Special execution)

15-f

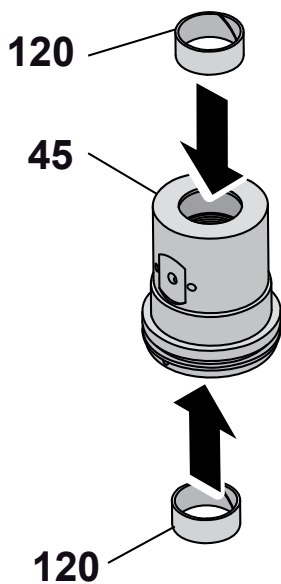

16-f

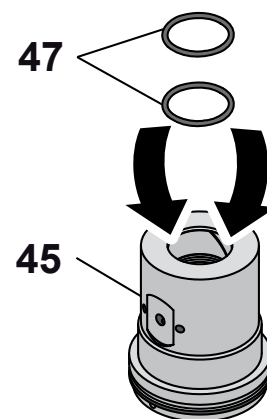

17-f

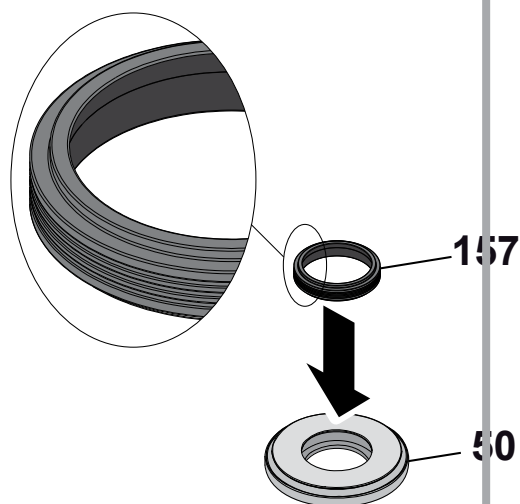
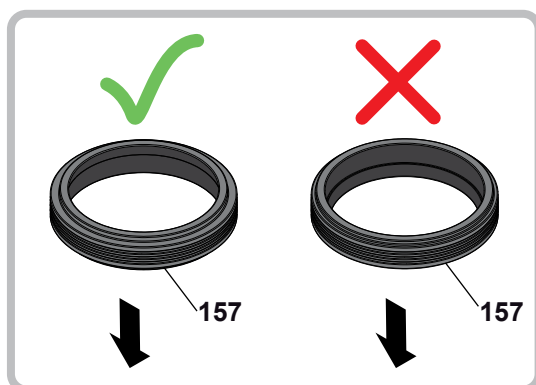

(BBYQ Special execution)

18-f

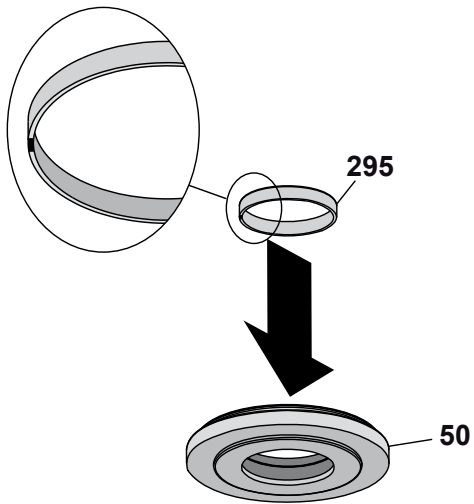

19-f

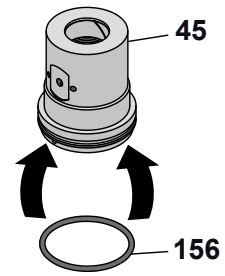

20-f

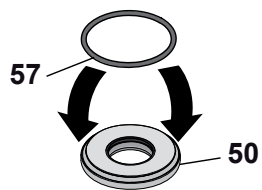

21-f

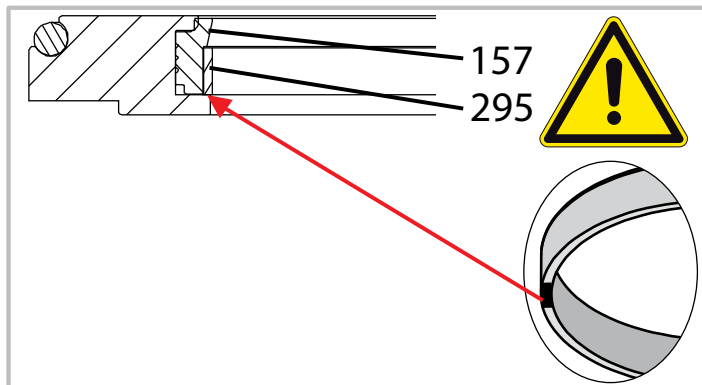
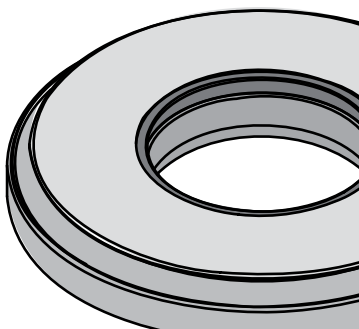
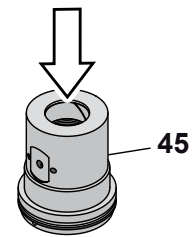
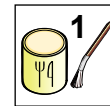

a

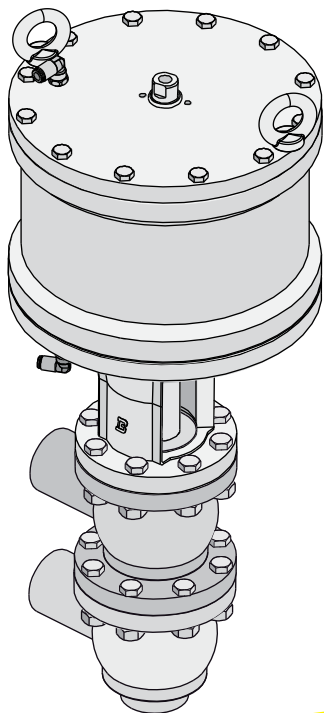

[A M D BBZQ-LL-207-360]

b

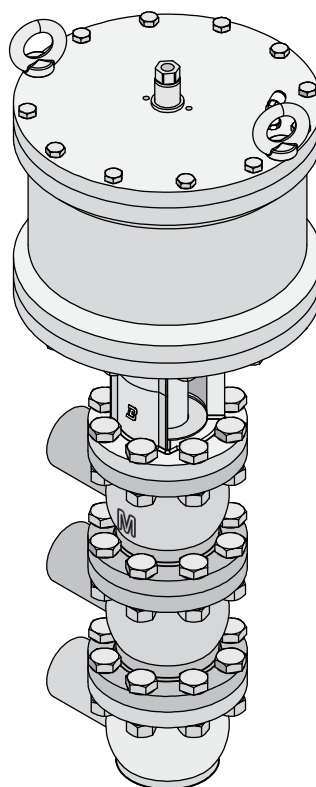

[B M BBZQ-M8LLL-207-360]

A Assembly of the BBZQ - BBYQ cylinder 207-360 Diverter

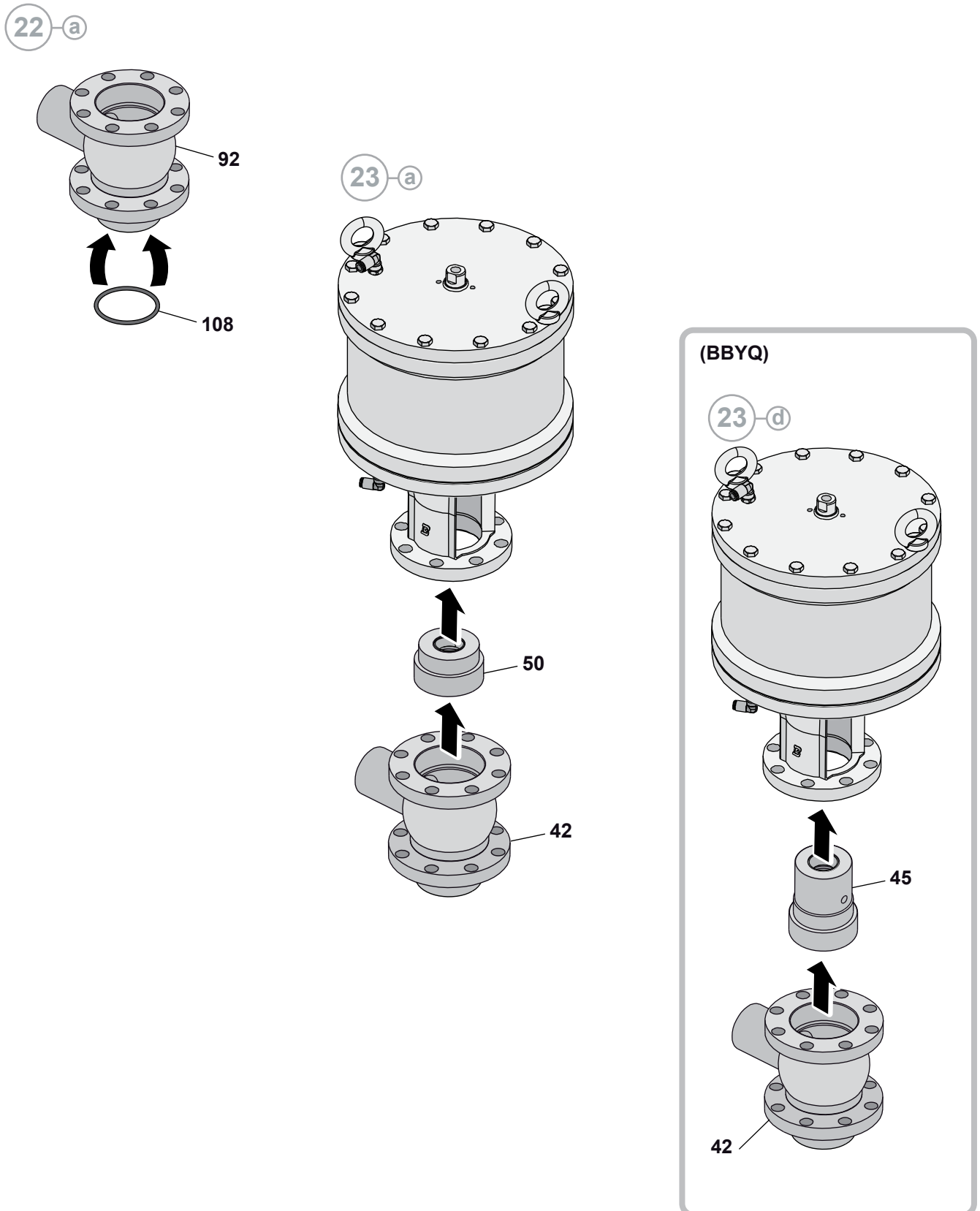

(BBYQ Special execution)

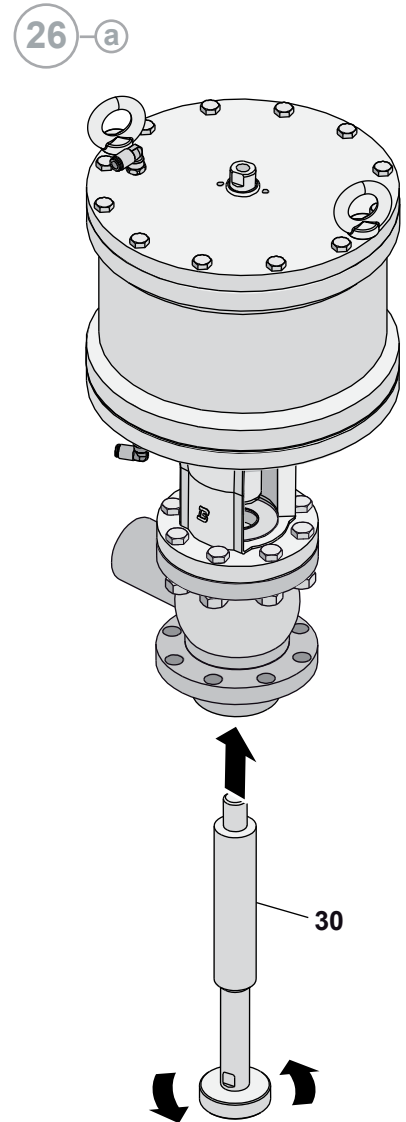
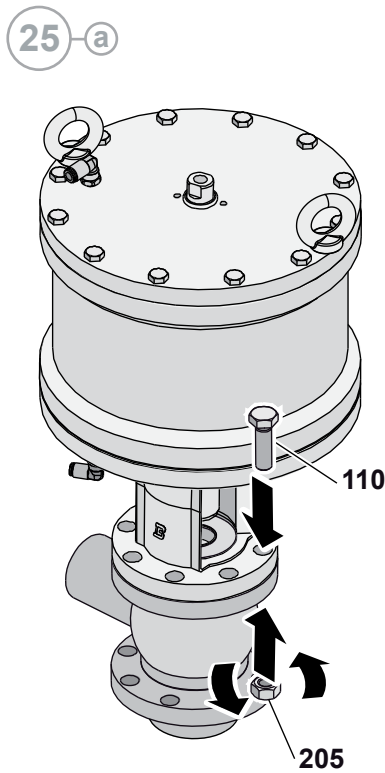
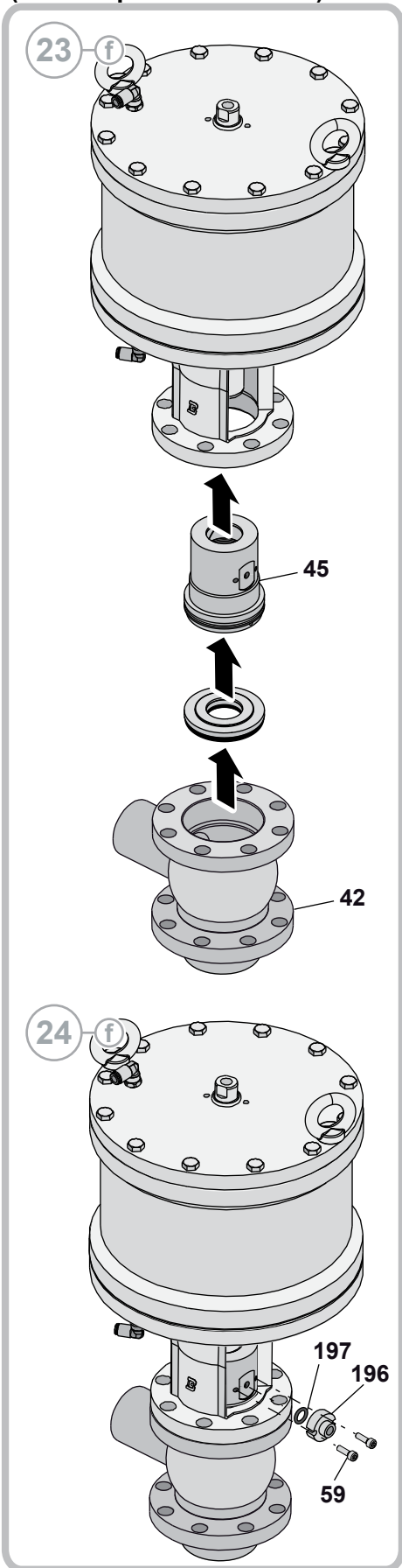

27-a

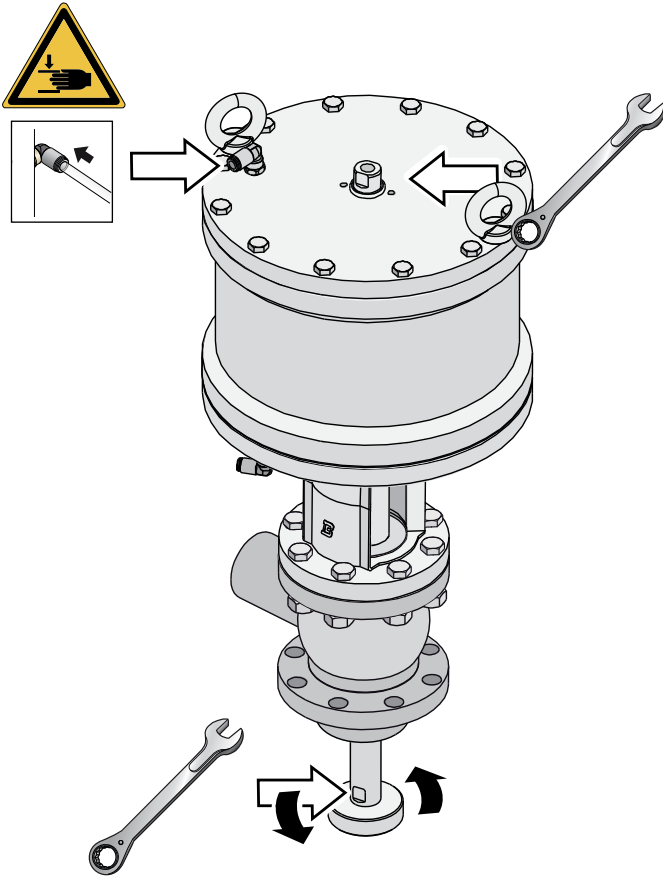

28-a

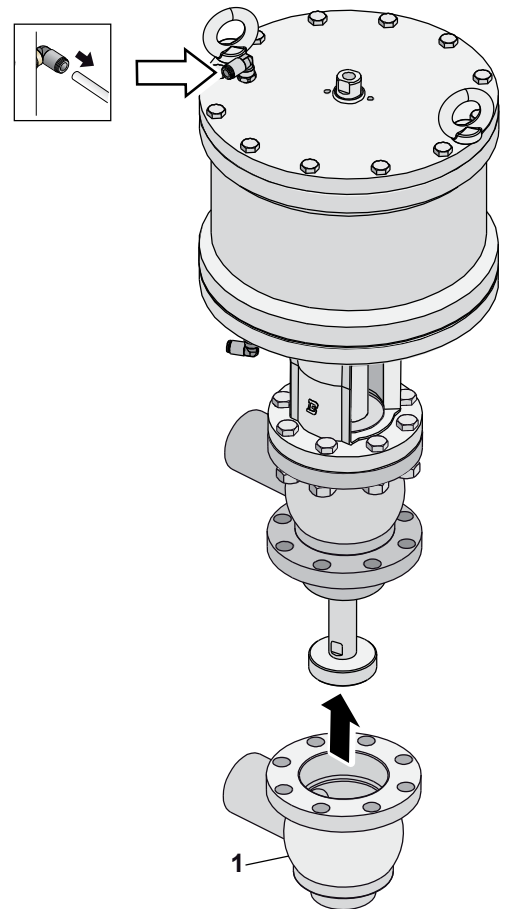

29 a

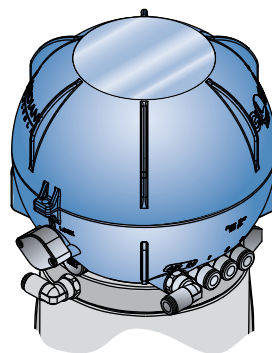
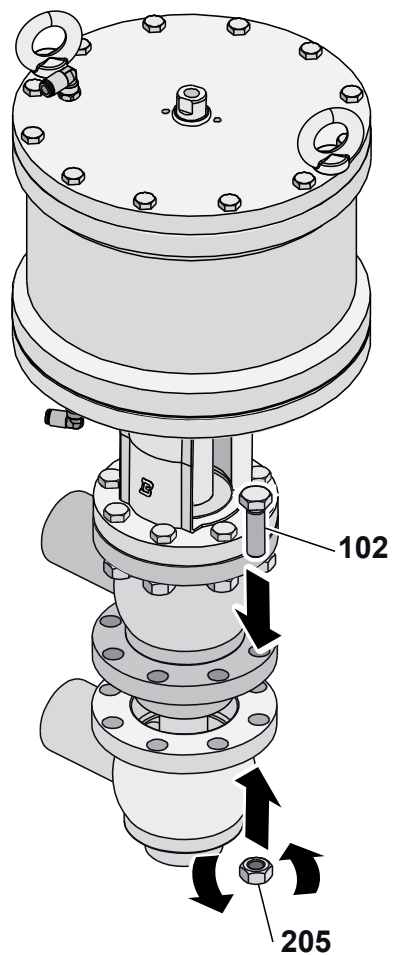

[M GIOTTO CYL.207]

B Assembly of the BBZQ M8-LLL cylinder 207-360 Diverter

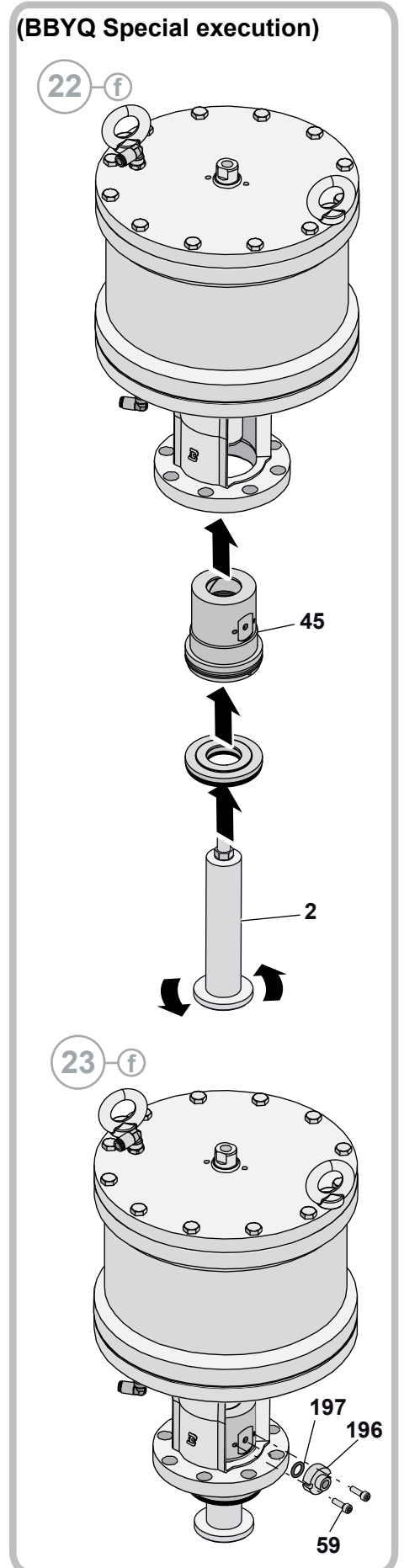
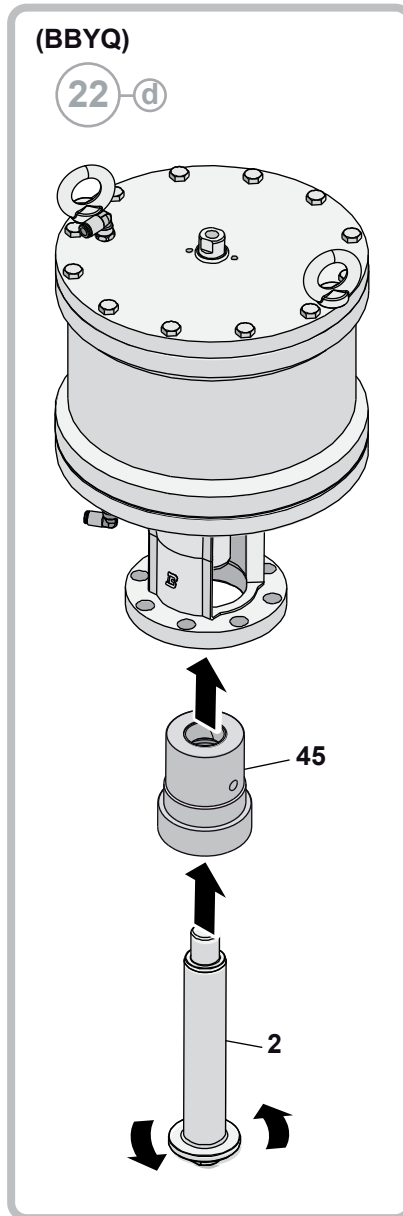
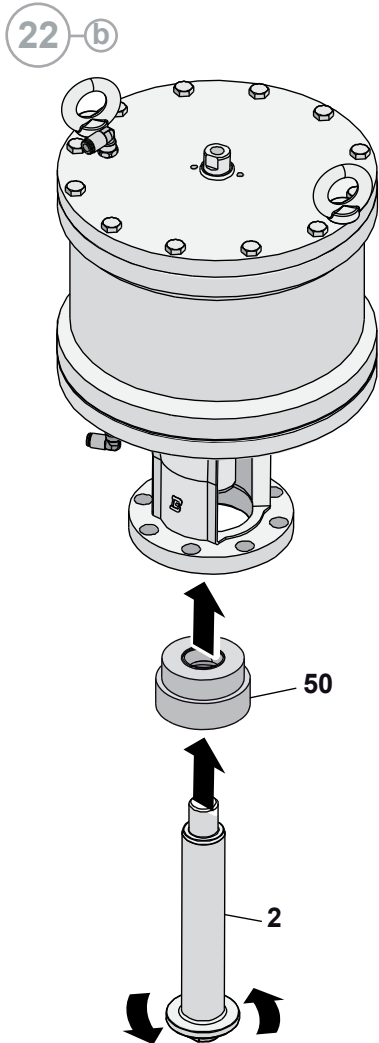

24-b

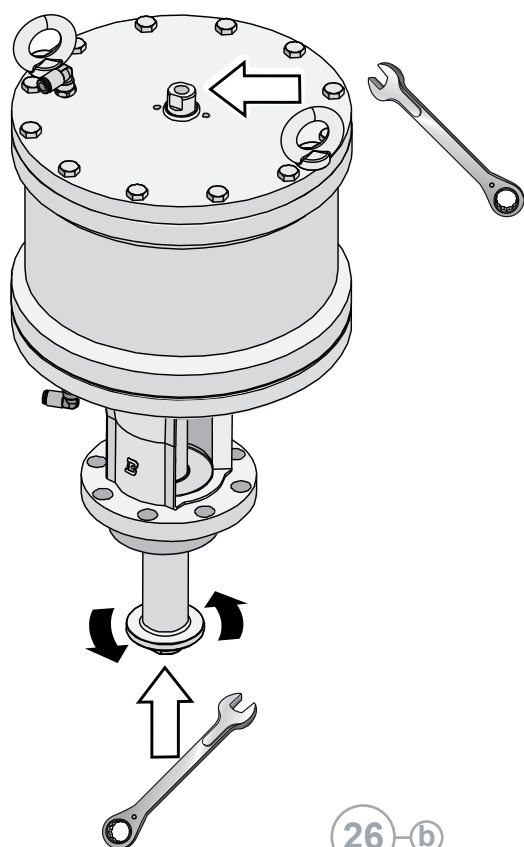

25-b

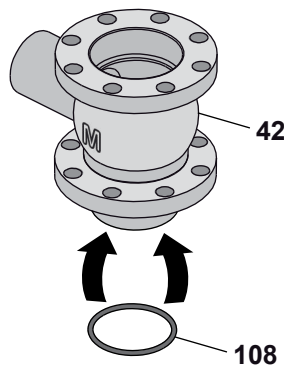

26-b

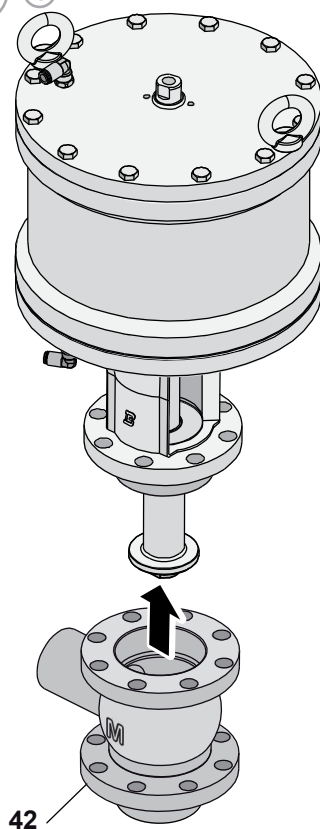

27-b

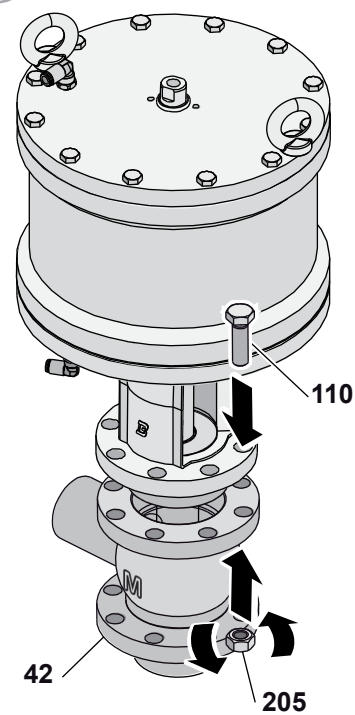

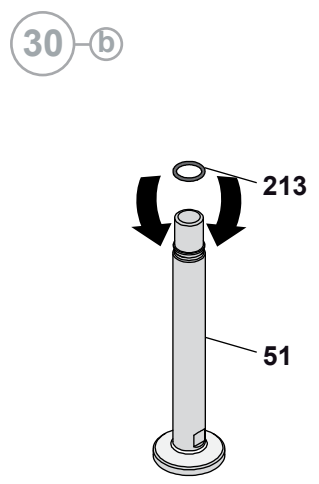
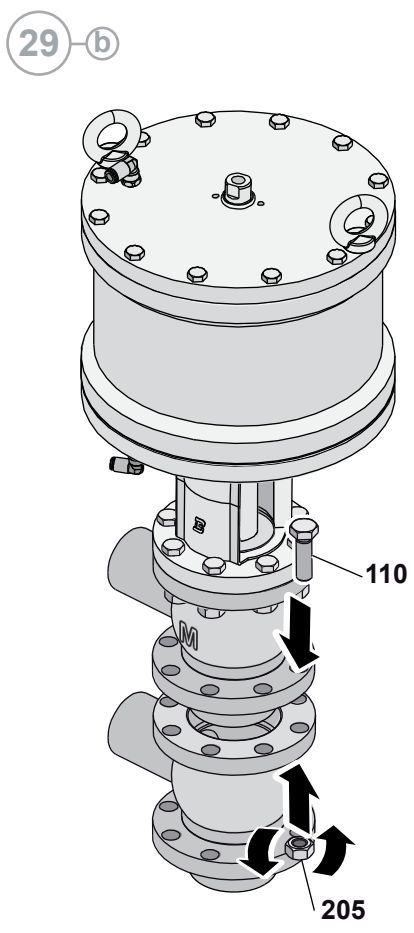
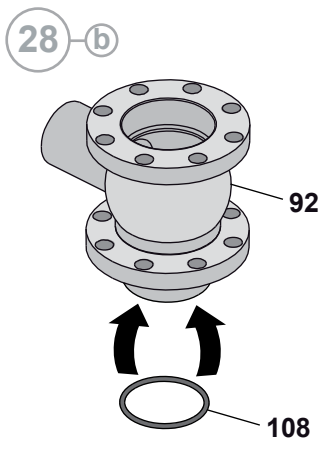

31-b

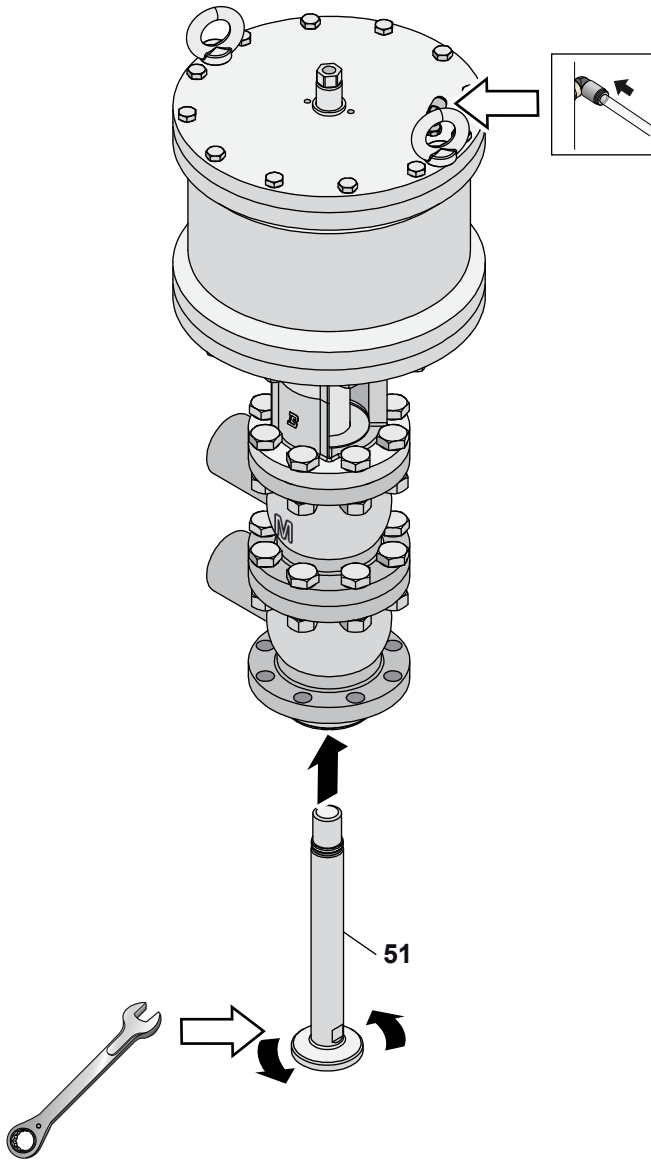

32-b

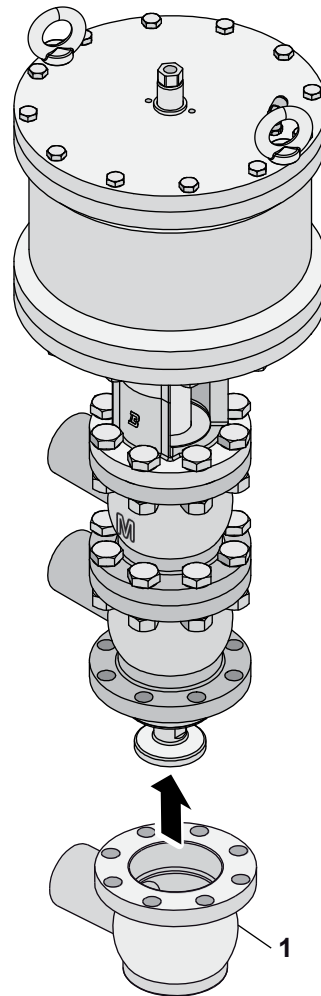

33 b

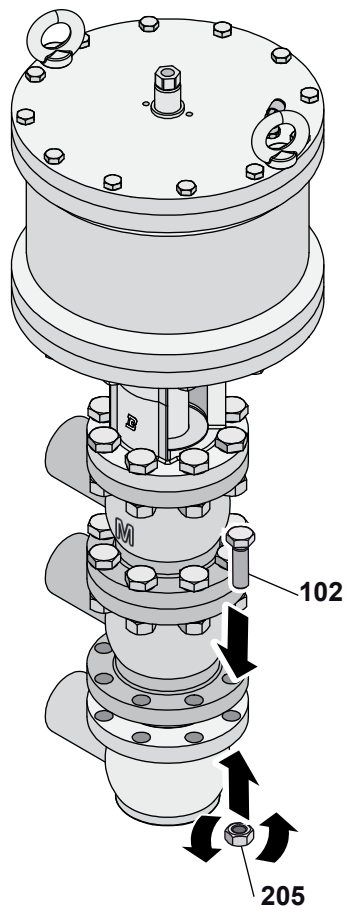

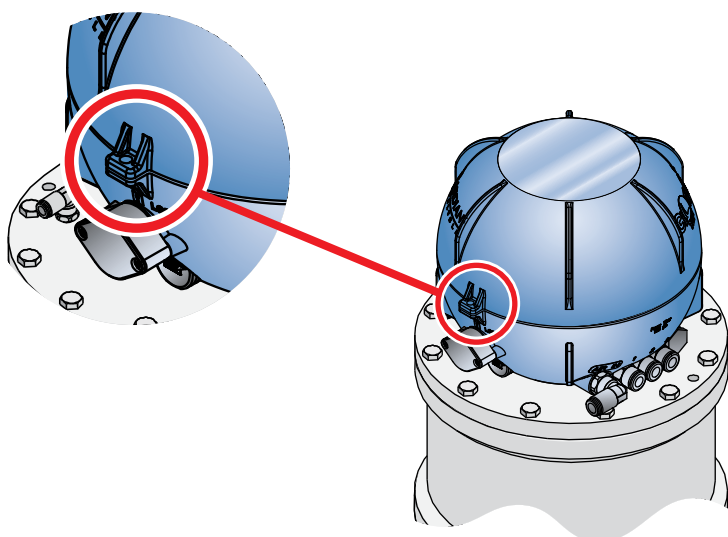
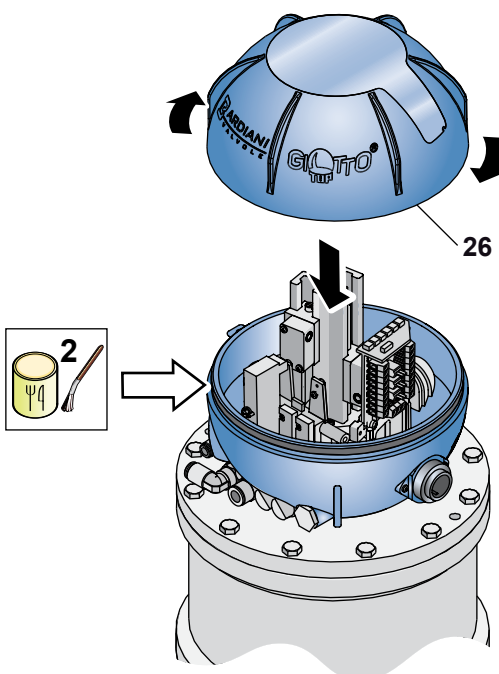
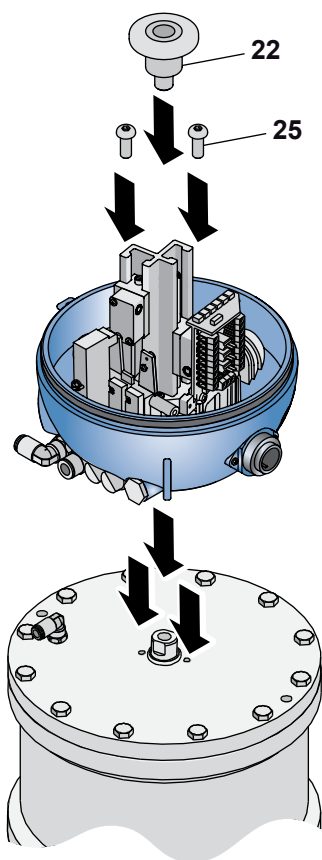

10.16 Idraulic damper for cilynder 207-360

NO.	DESCRIPTION
6	Sealing ring
7	Sealing washer
8	Screw
9	Cylinder
10	Bush
35	Assembly
125	Damper
276	Sealing ring
277	Sealing ring

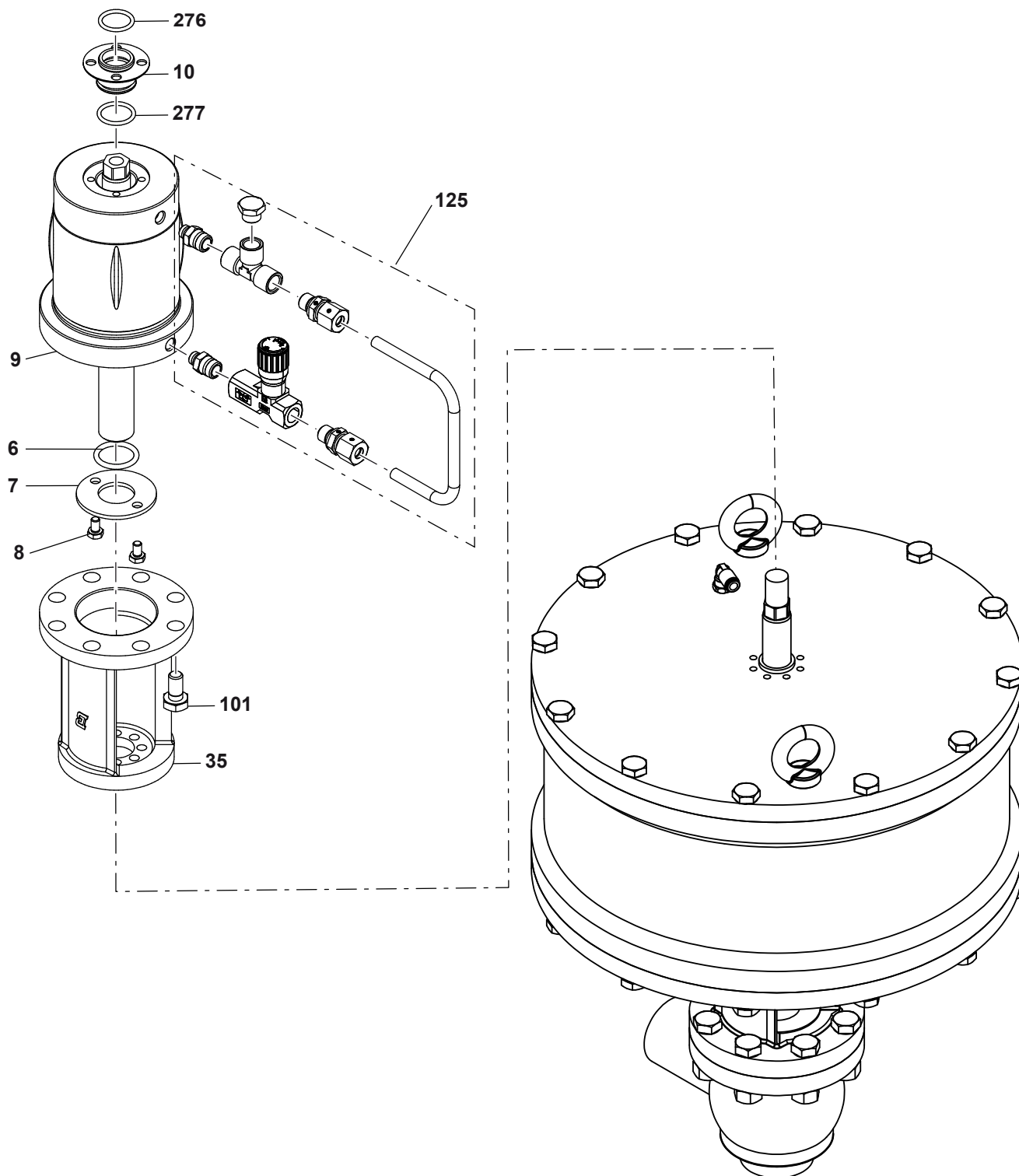

10.17 Disassembly of idraulic damper for cilynder 207-360

1

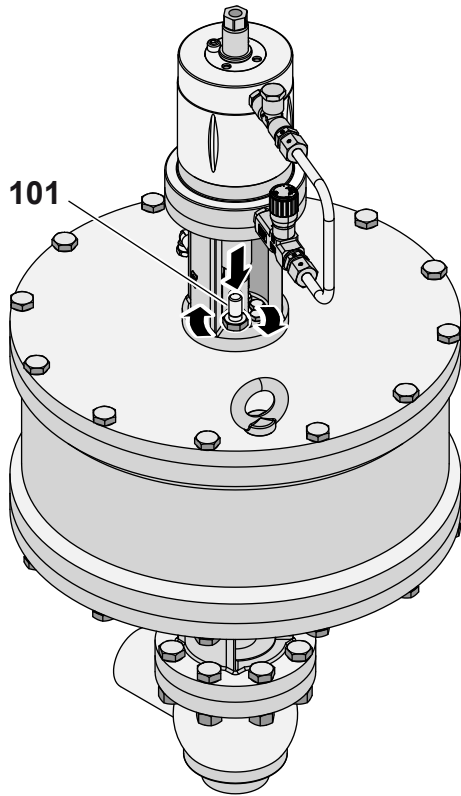

2

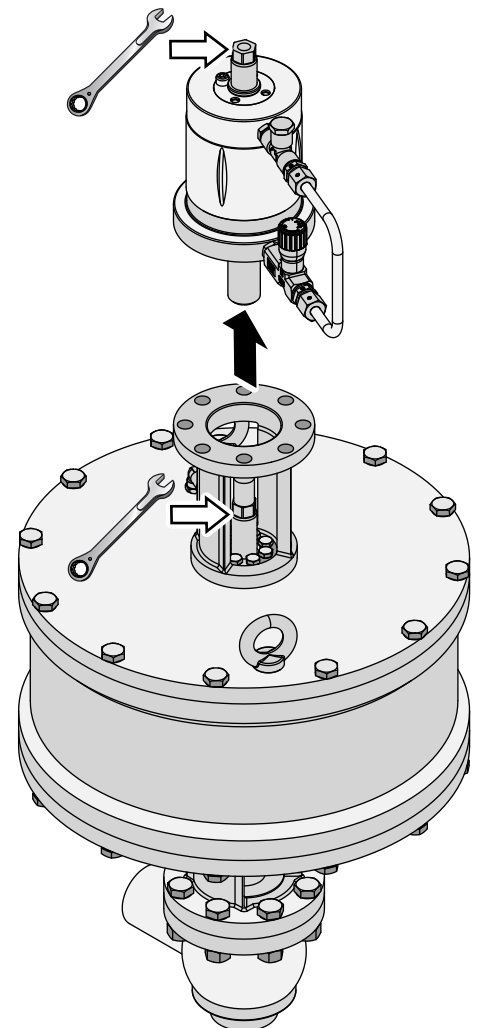

3

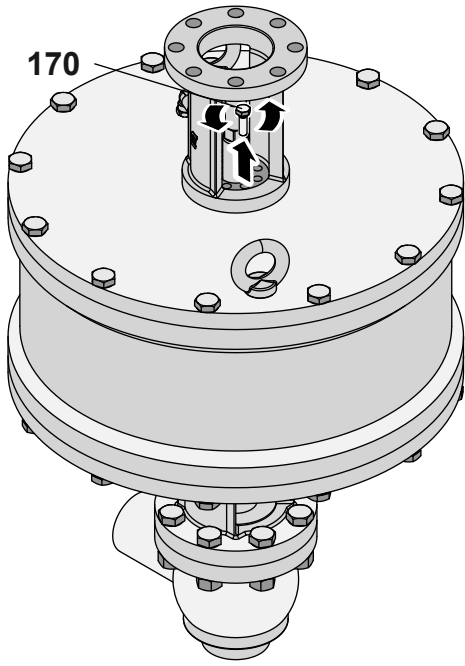

4

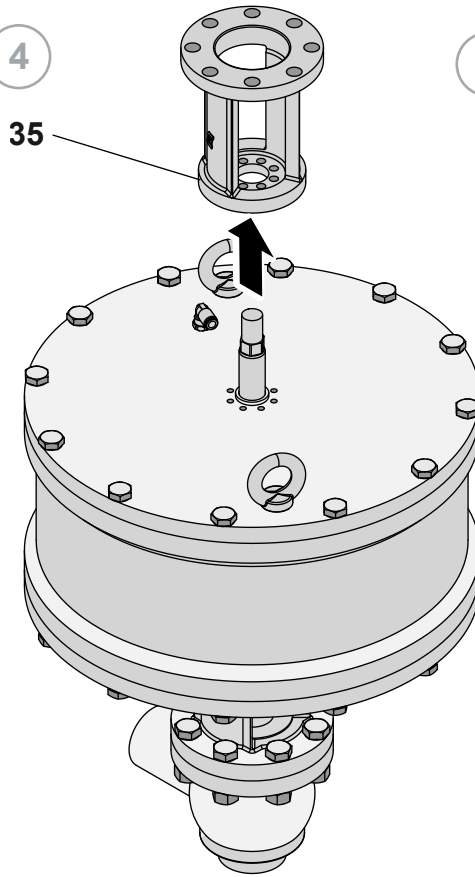

5

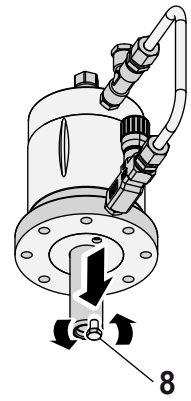

6

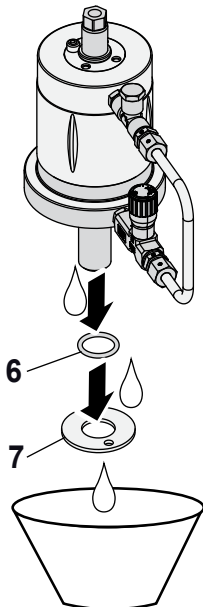

7

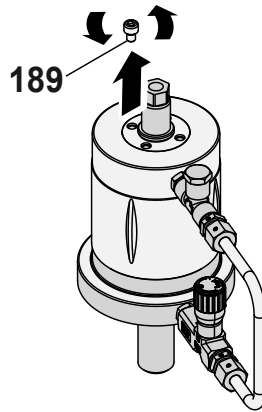

8

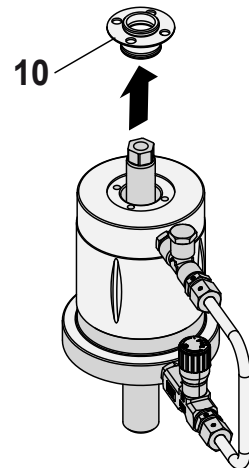

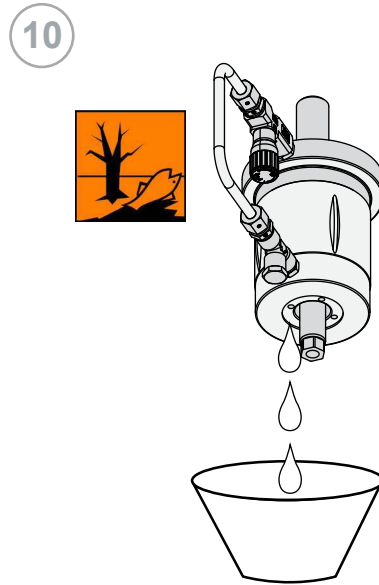
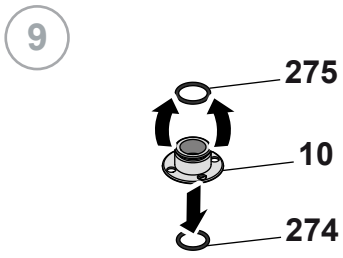

10.18 Assembly idraulic of damper for cilynder 207-360

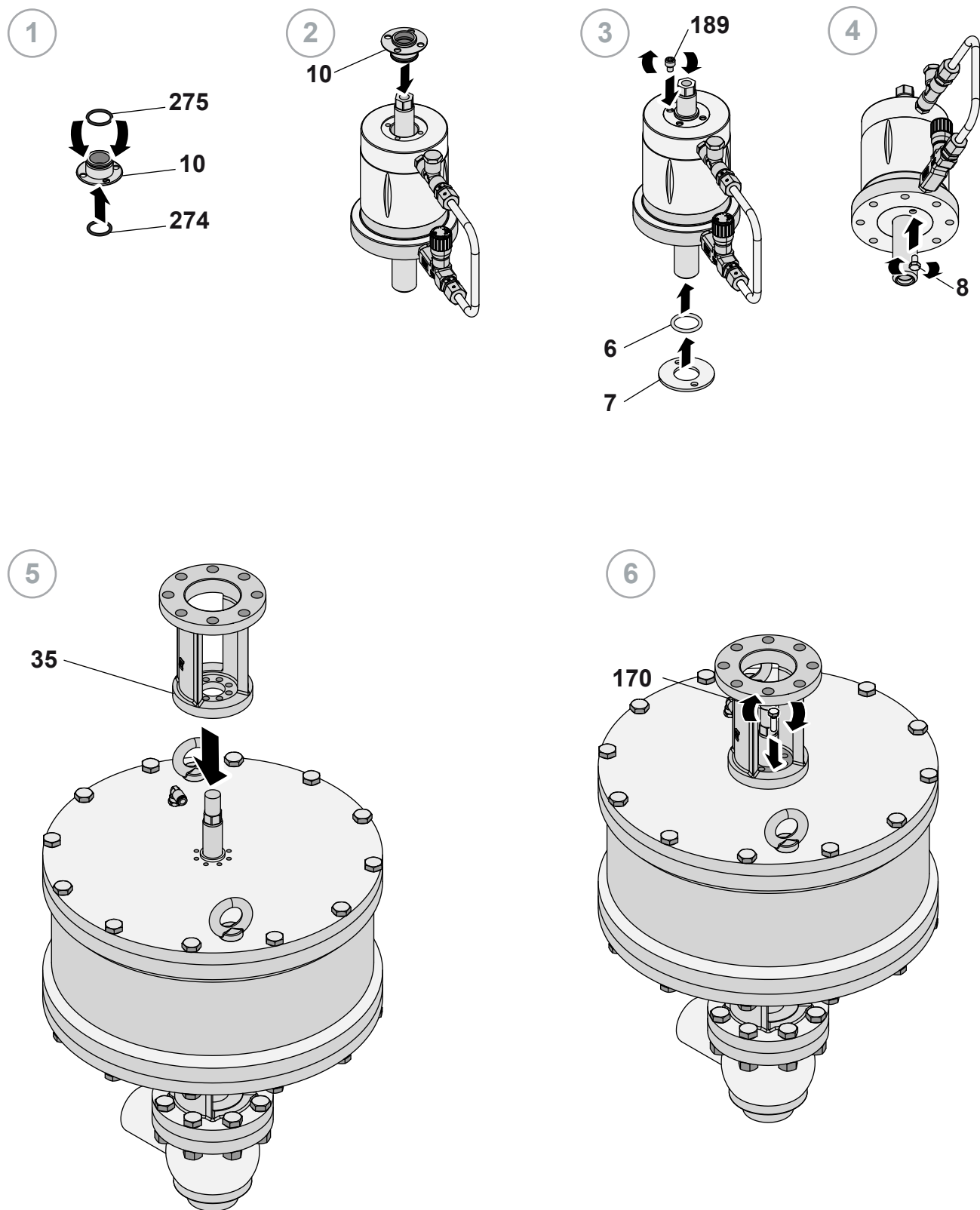

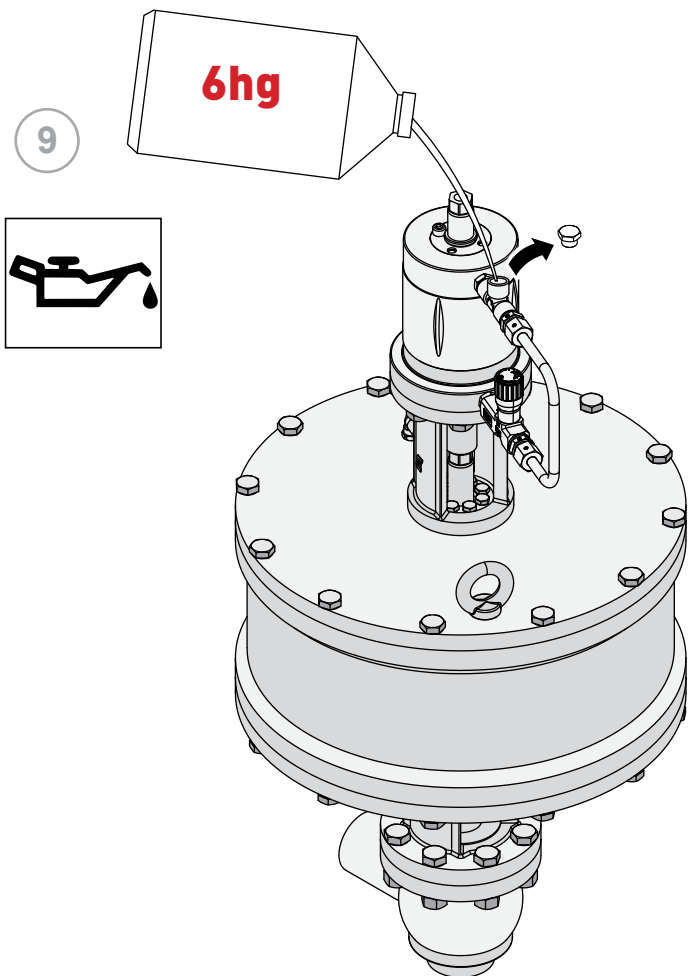
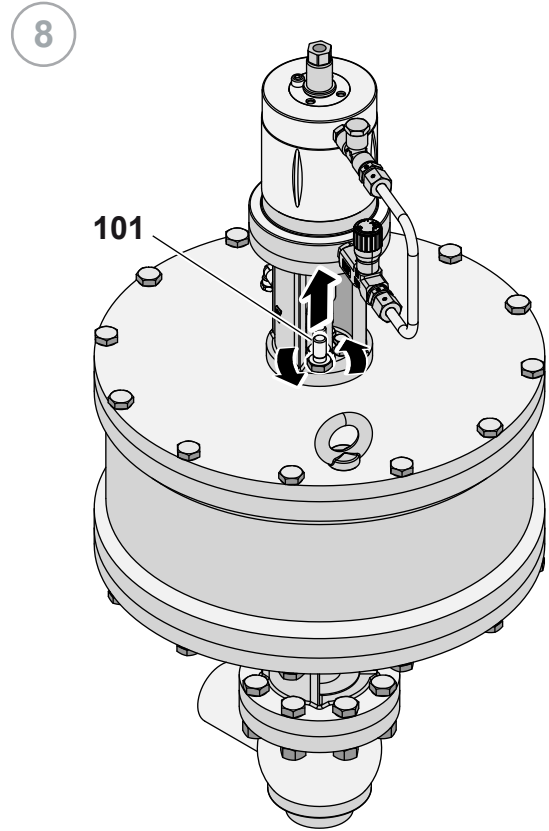
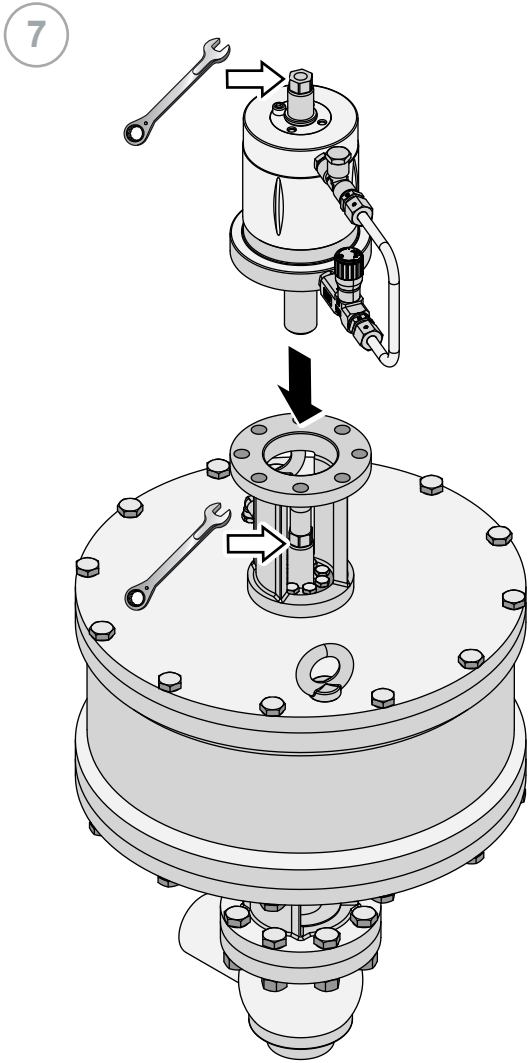

10.19 Pneumatic Valves BBZU

NO.	DESCRIPTION
23	Upper pin
24	Air connector
66	Piston
88	Grub screw
99	Cylinder
129	Pin
169	Sealing ring
170	Screw
171	Sealing ring
172	Sealing ring
173	Buffer
175	Bush
177	Elastic wire
204	Bush

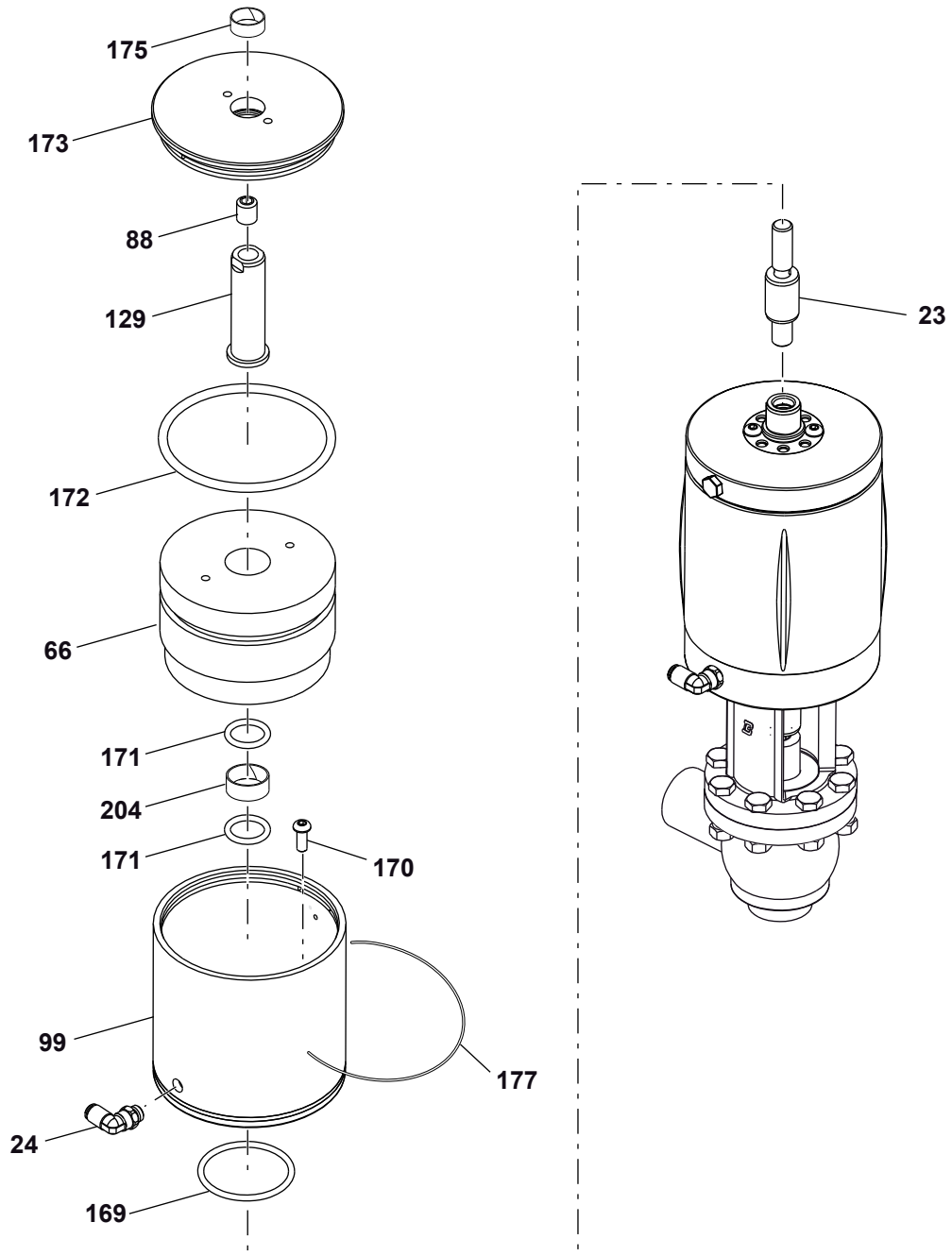

10.20 Disassembly of the BBZU

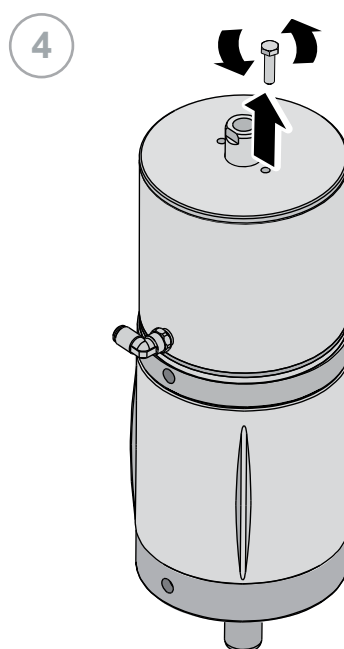
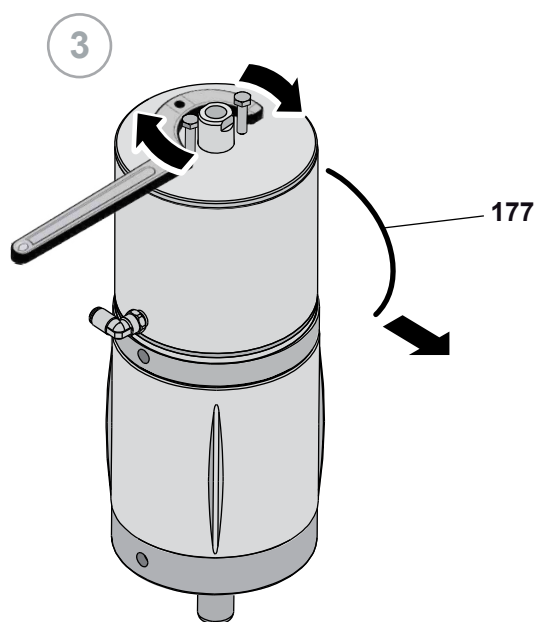
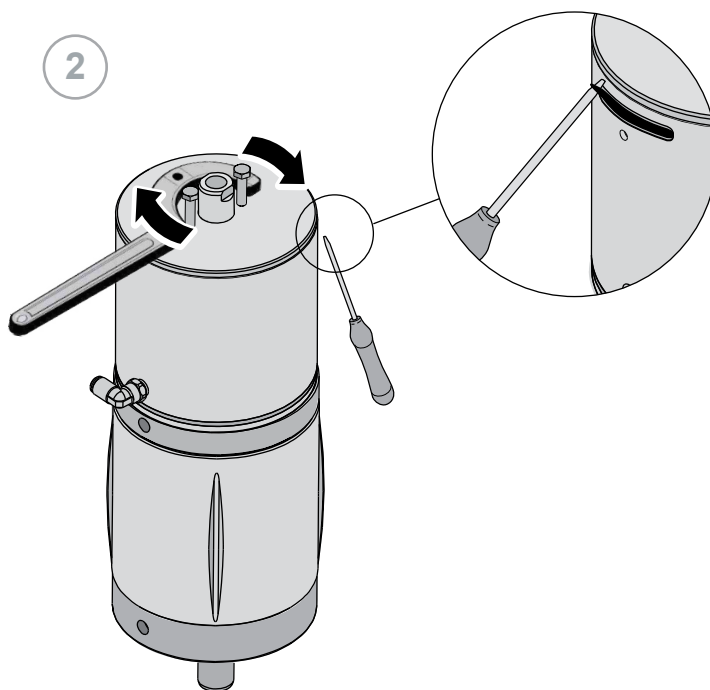
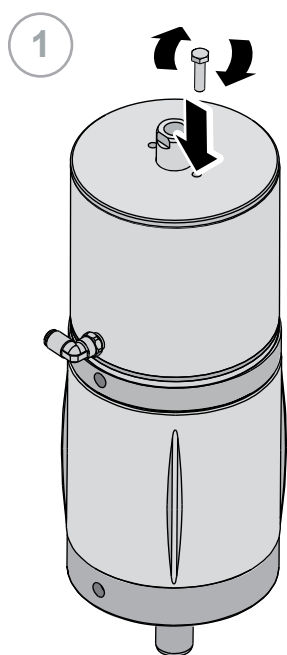

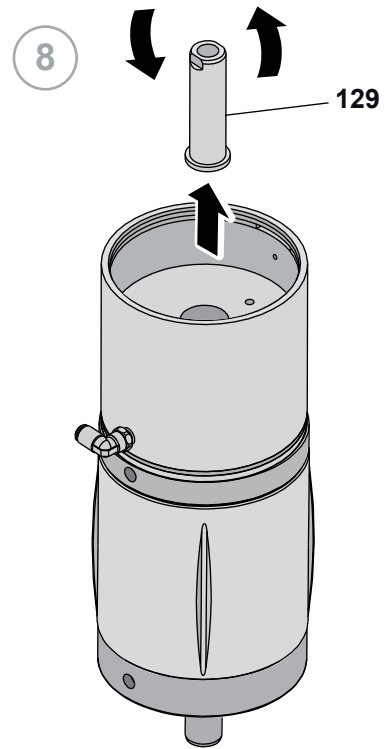
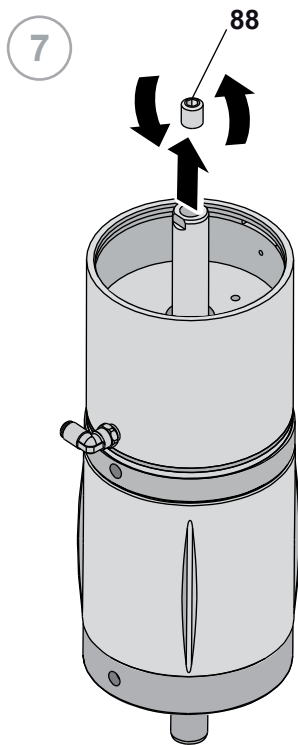
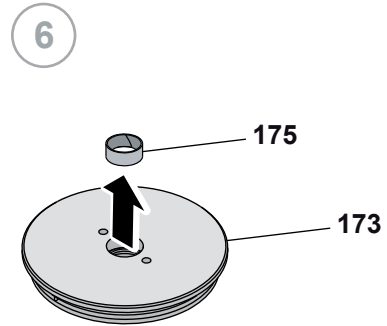
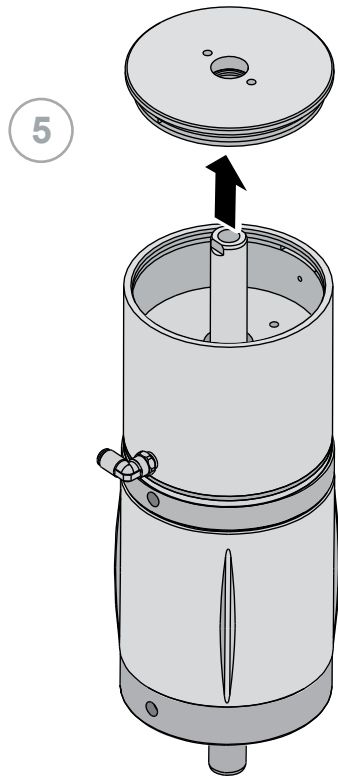

9

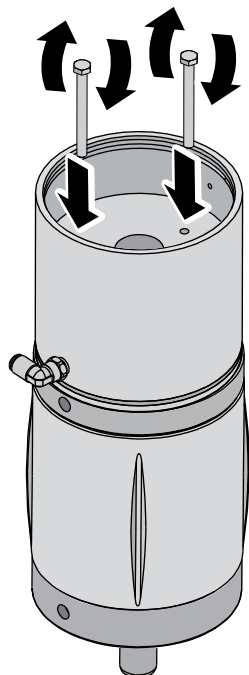

10

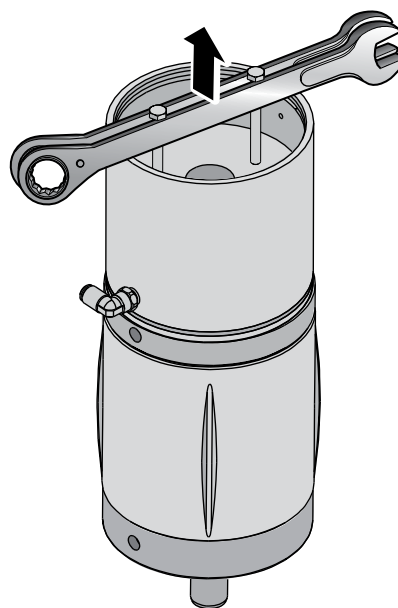

11

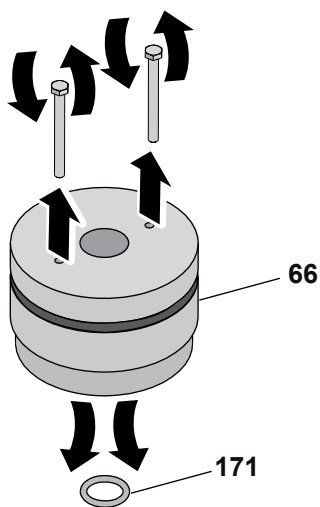

12

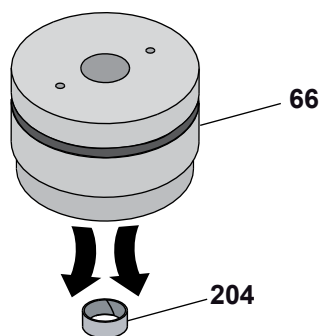

13

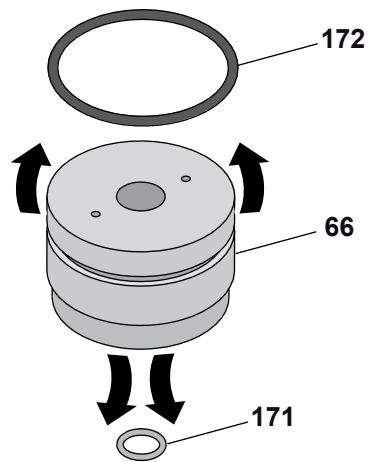

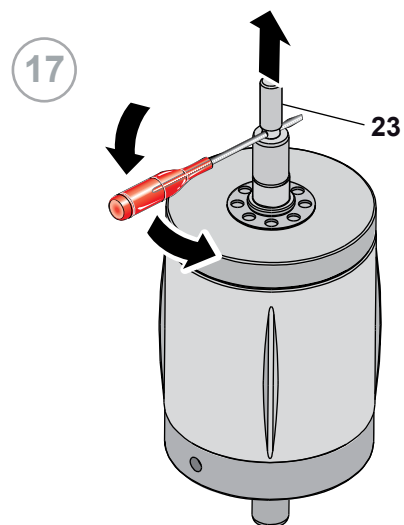
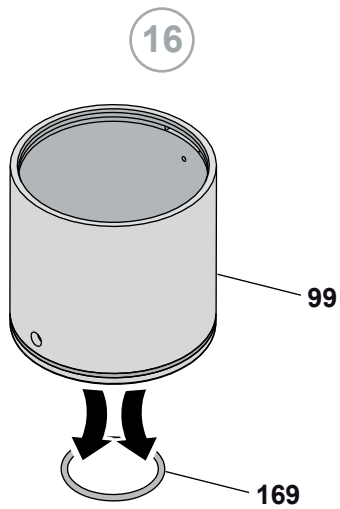
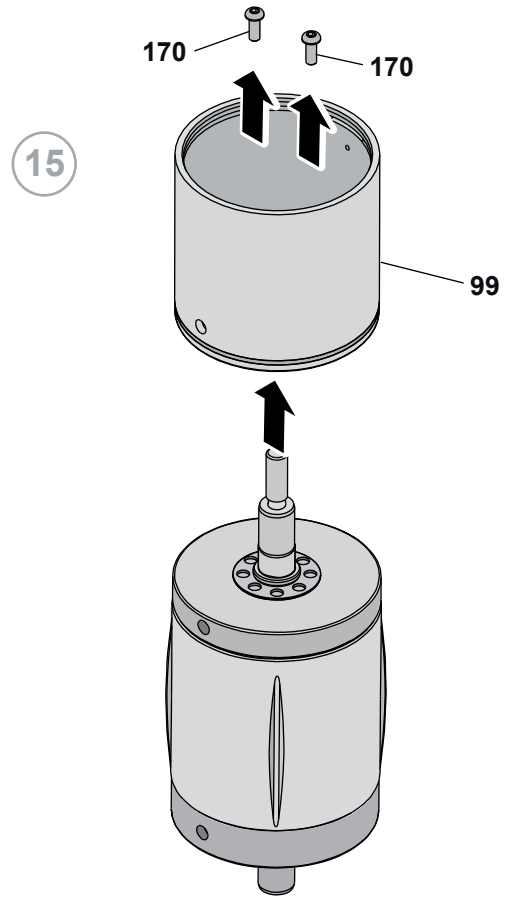
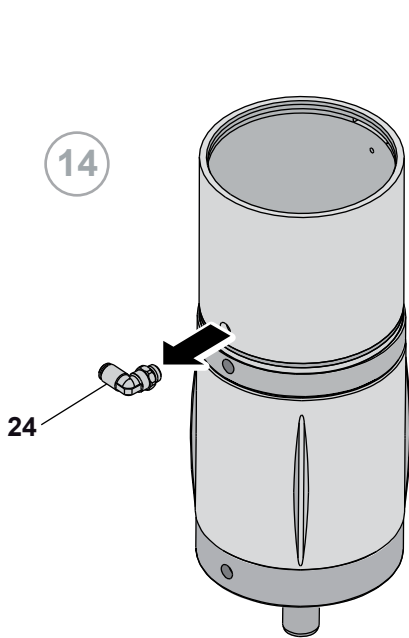

10.21 Assembly of the BBZU

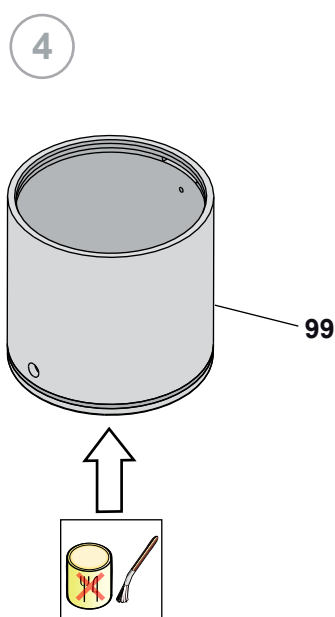
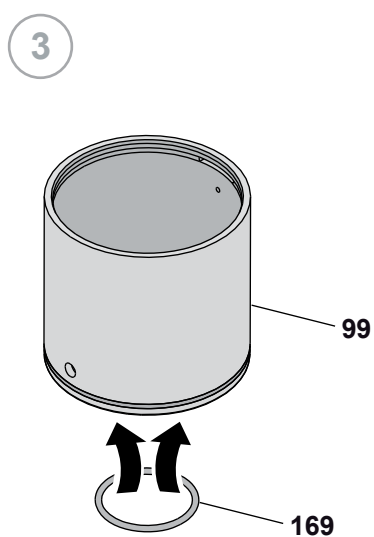
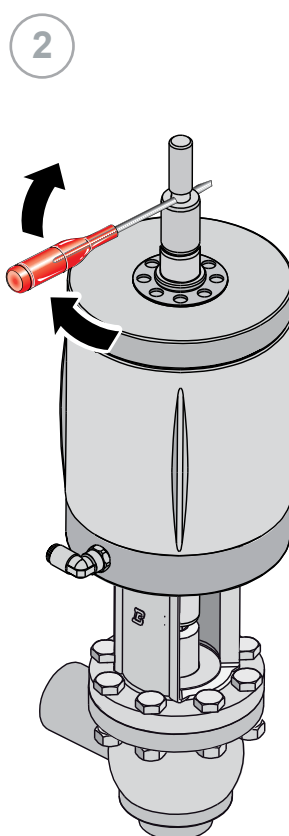
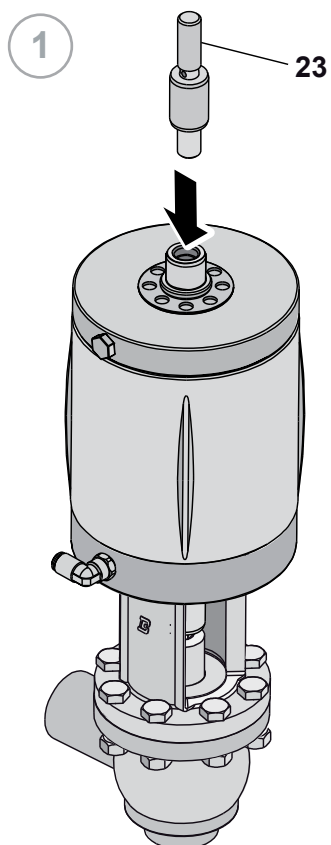

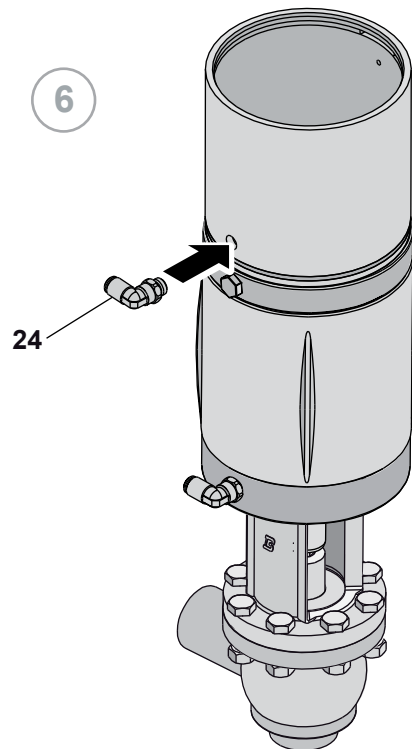
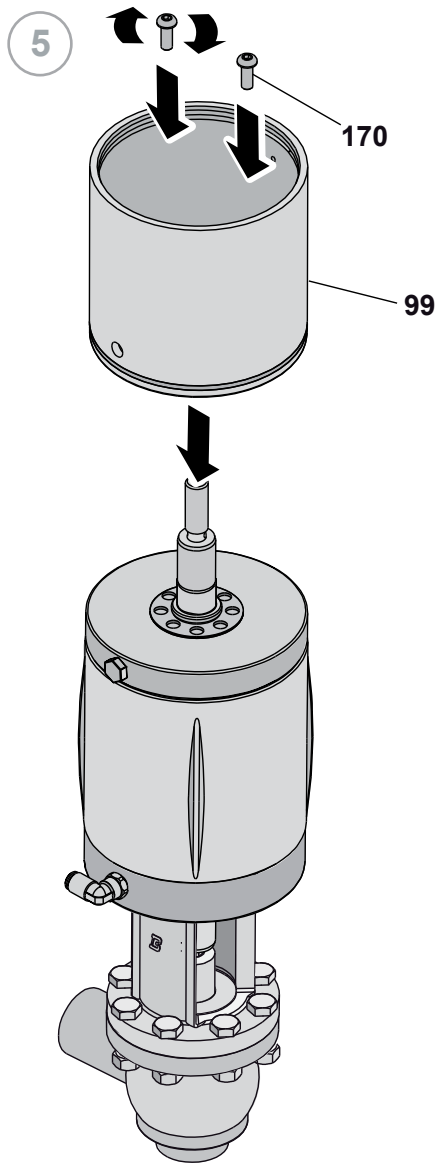

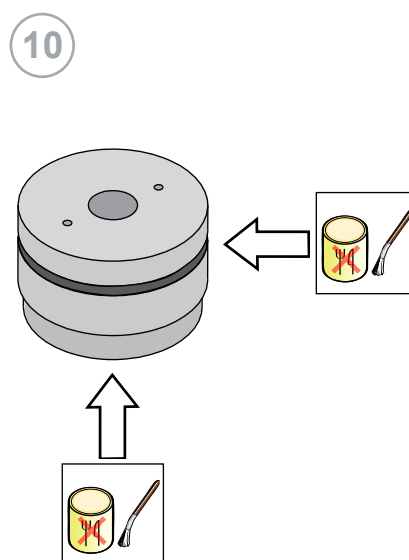
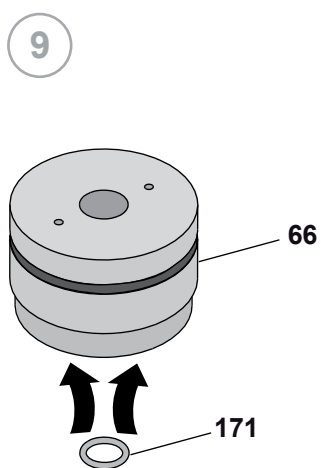
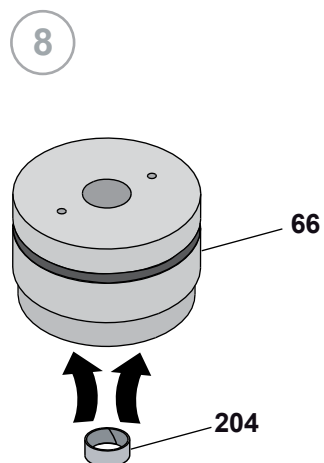
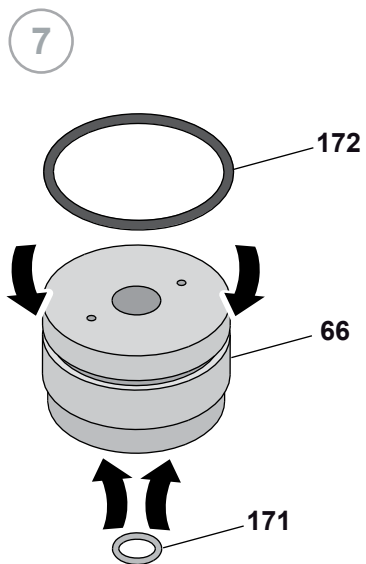

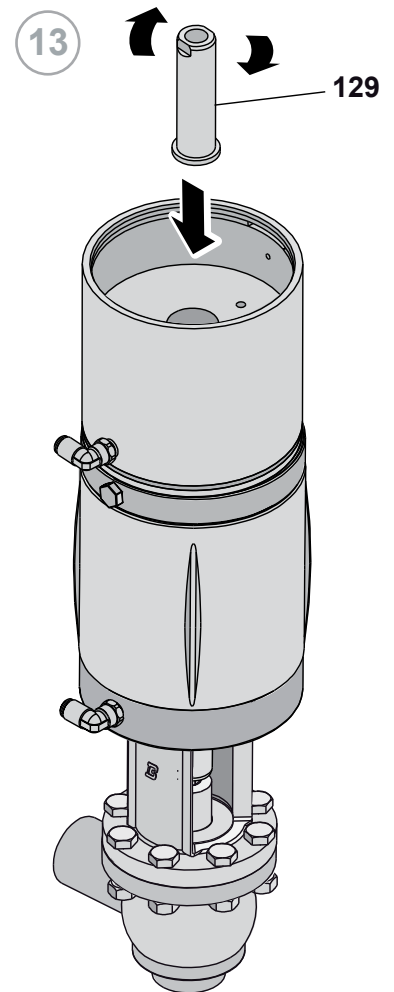
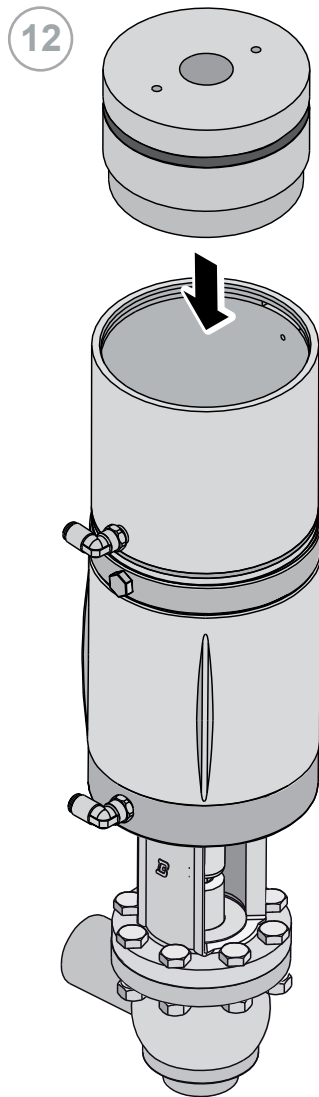
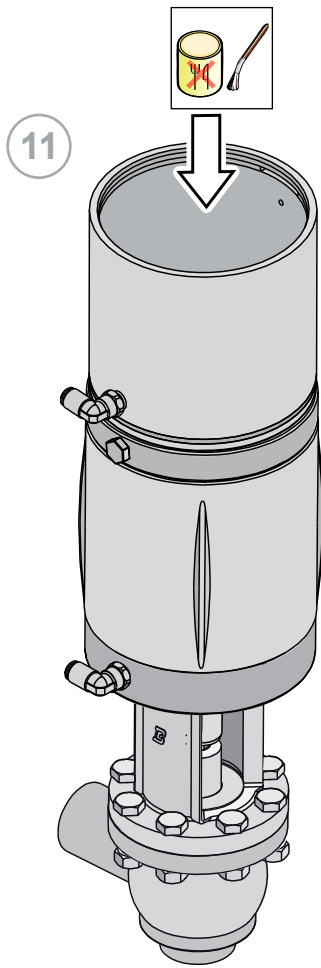

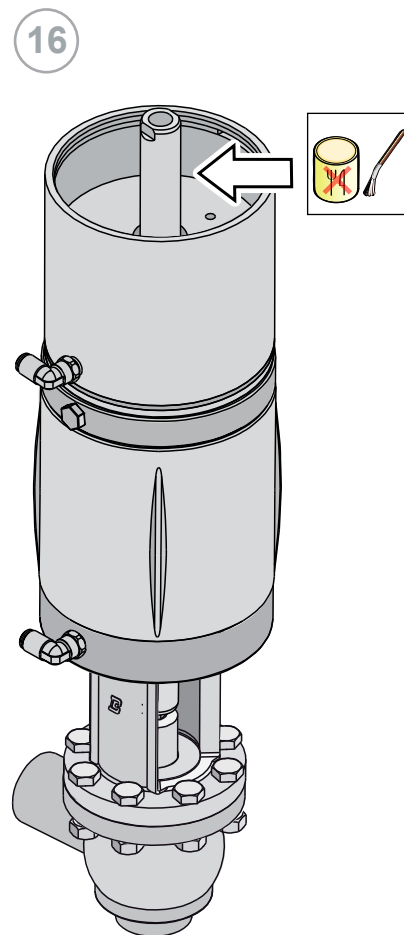
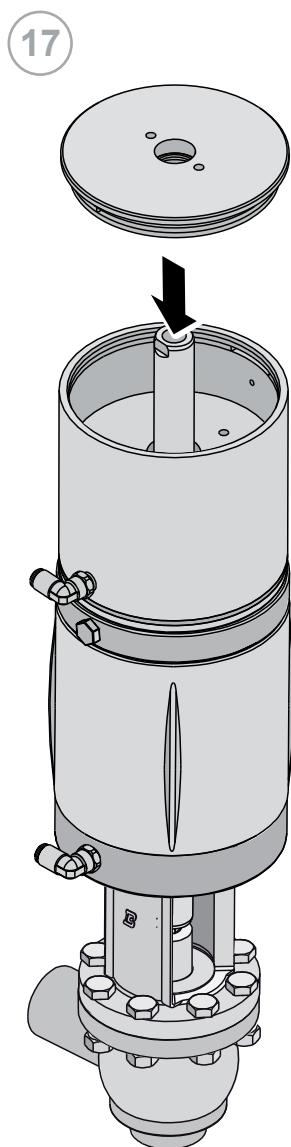
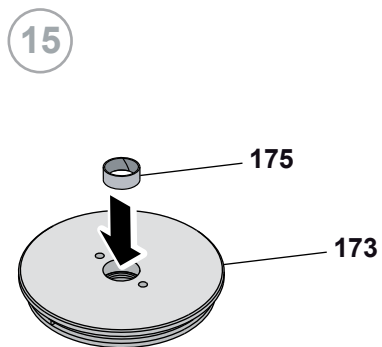
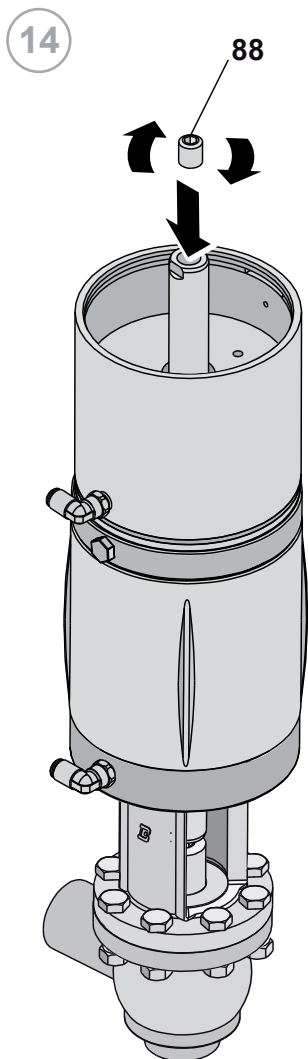

18

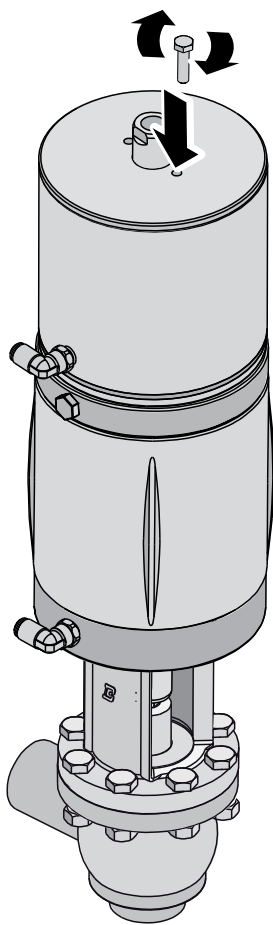

19

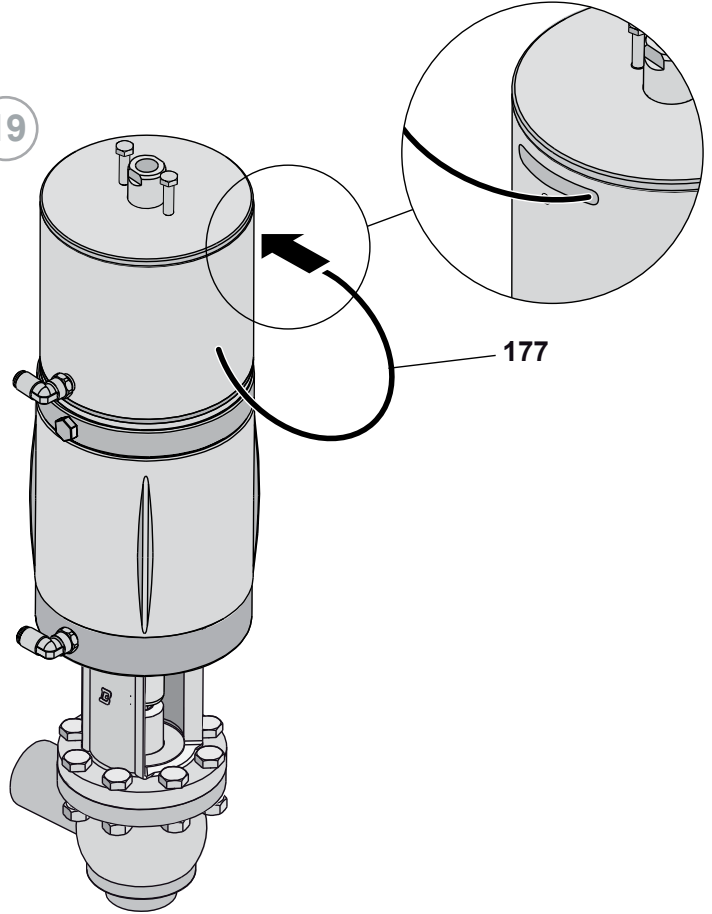

20

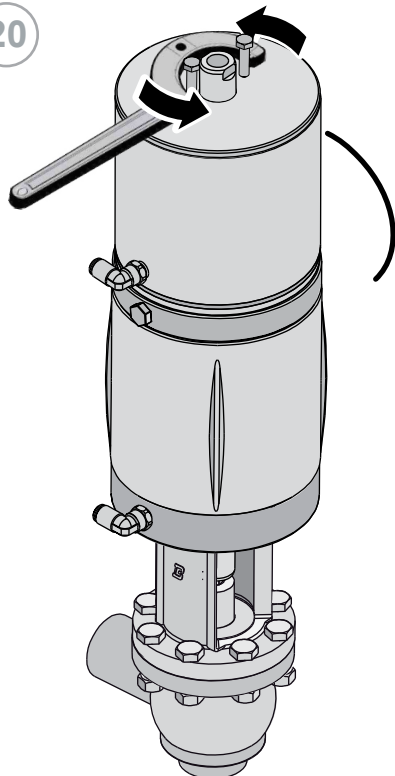

21

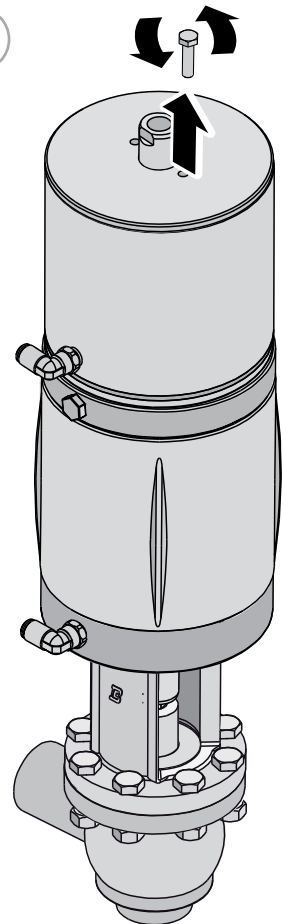

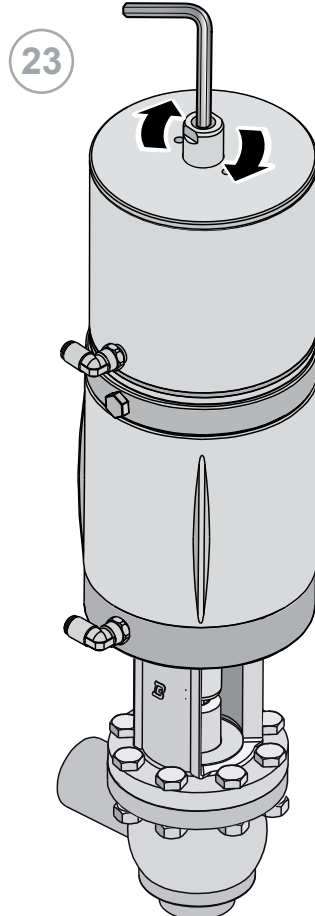
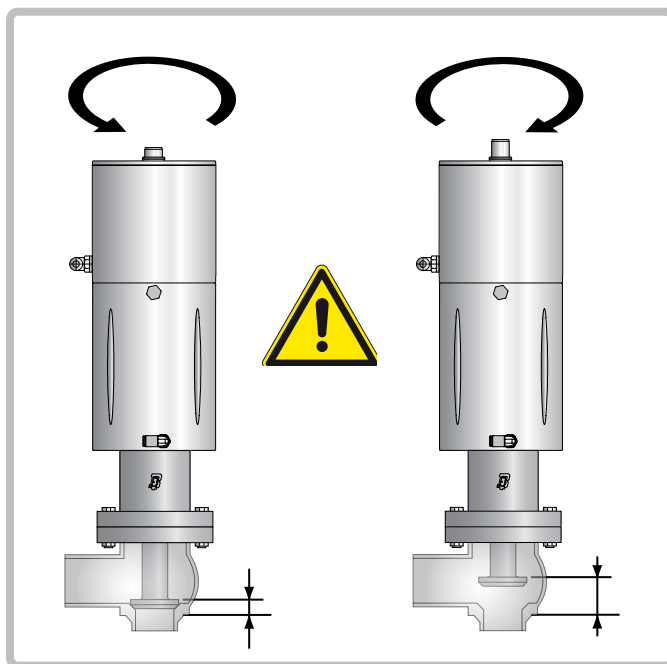
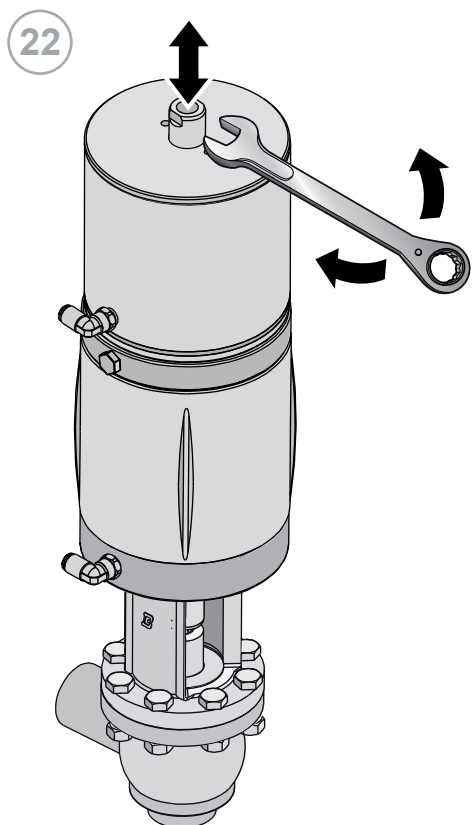

11 Annexes



GB - EC Declaration of conformity - without electric components - A5-P-PRG-GB

EC DECLARATION OF CONFORMITY OF THE MACHINERY

(EC) 2006/42, Annex. II, p. 1 A

BARDIANI VALVOLE S.p.A.

Via G. di Vittorio 50/52 – 43045 Forno di Taro (Pr) – Italia

Declares

under its own responsibility that the machine:

Type:	PNEUMATIC VALVES
Model:	#####
Serial number:	#####
Function:	Fluid handling
Year of construction:	2018
Reference	#####

complies with all relevant provisions of the following EC directives:

(EC) 2006/42 MACHINERY

and the following harmonized standards, rules and / or technical specifications applied:

EN ISO 12100:2010

REGULATION (EC) 1935/2004 and subsequent amendments and additions with regard to steel and elastomers in contact with the product

Fornovo di Taro

20/09/2018

Legal Representative

A5-P-PRG-GB Ed. 1. Rev. 0

BARDIANI VALVOLE S.p.A.
Via G. di Vittorio 50/52
43045 Forno di Taro (Pr)

12 2D Diagram BBZQ cylinder 108-156

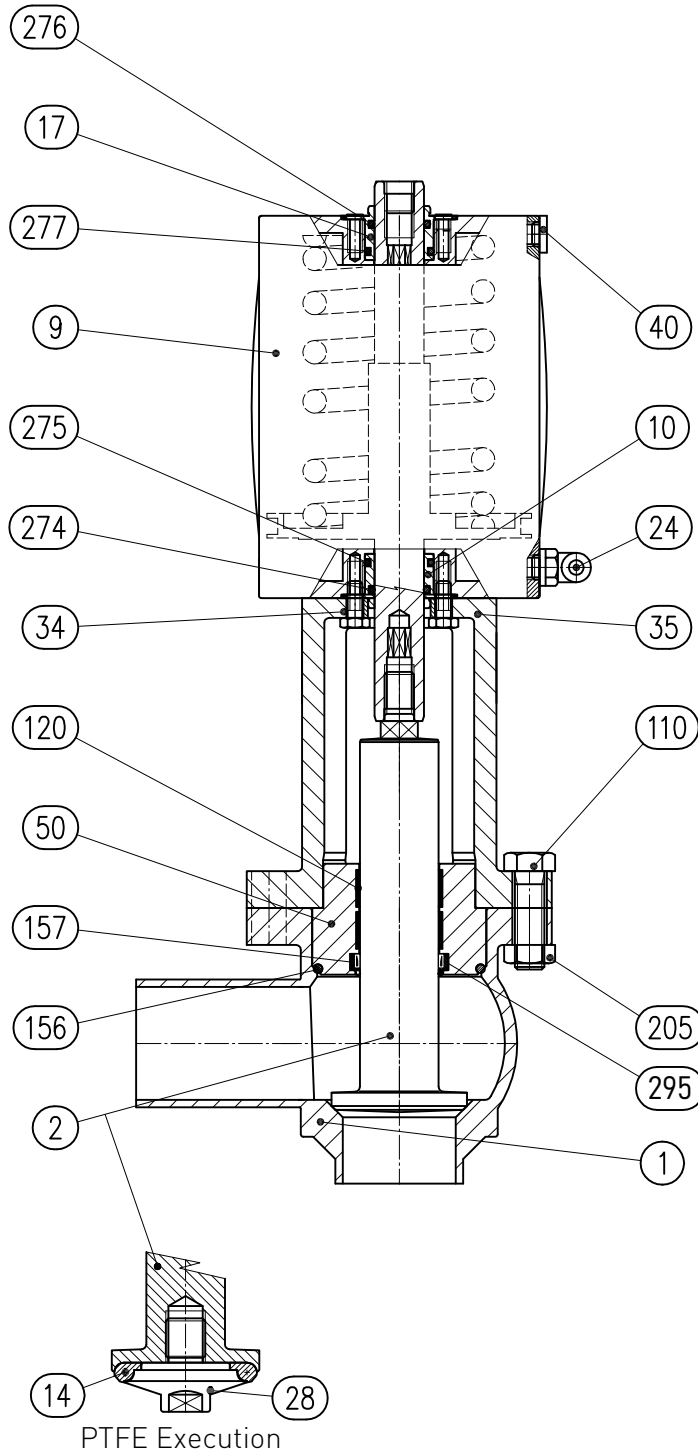

[BBZQ-108-156]

15 2D Diagram BBZQ cylinder 108-156 Diverter

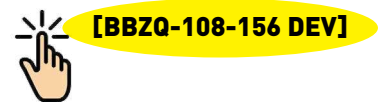
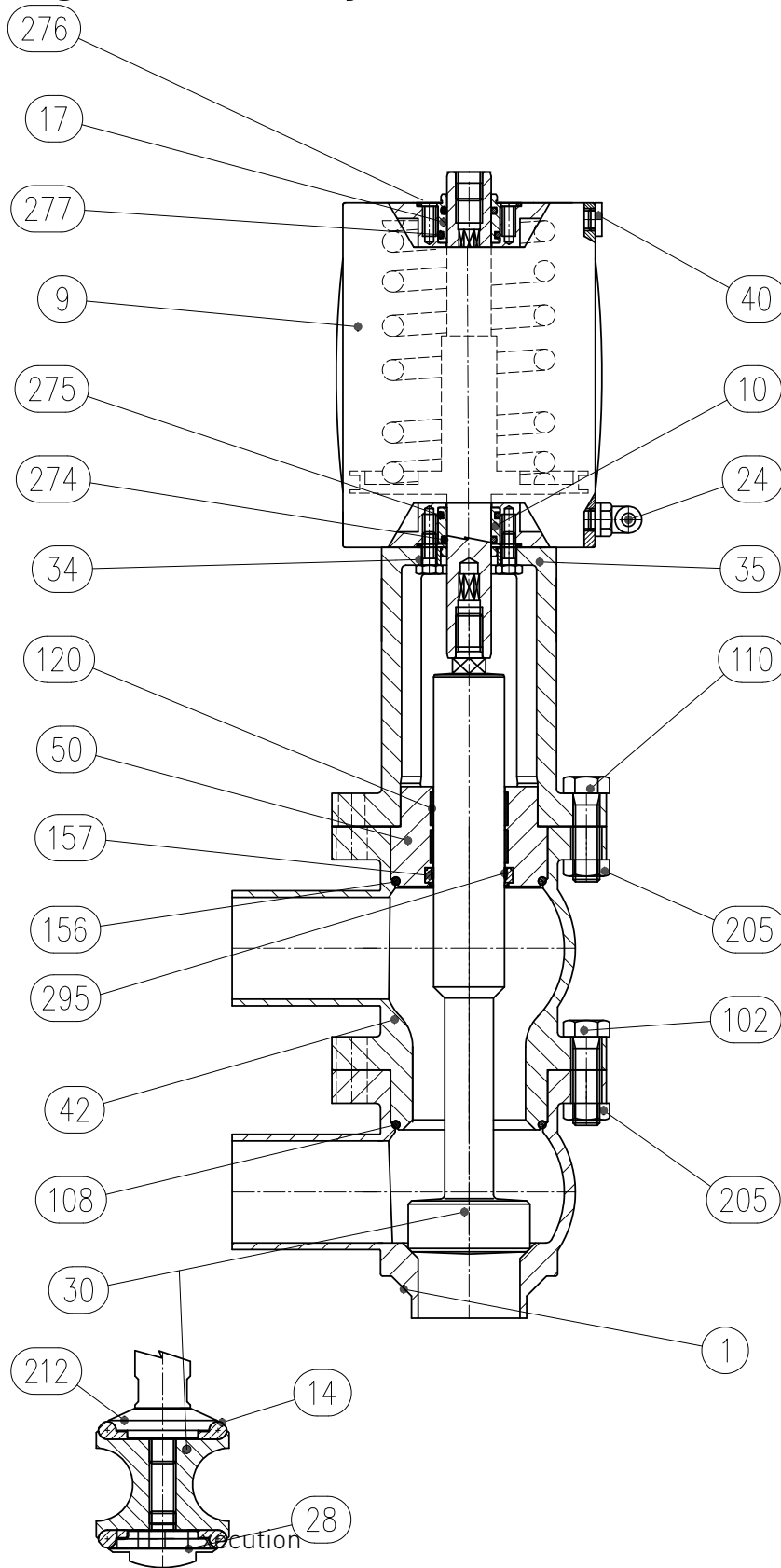

16 2D Diagram BBYQ cylinder 108-156 Diverter

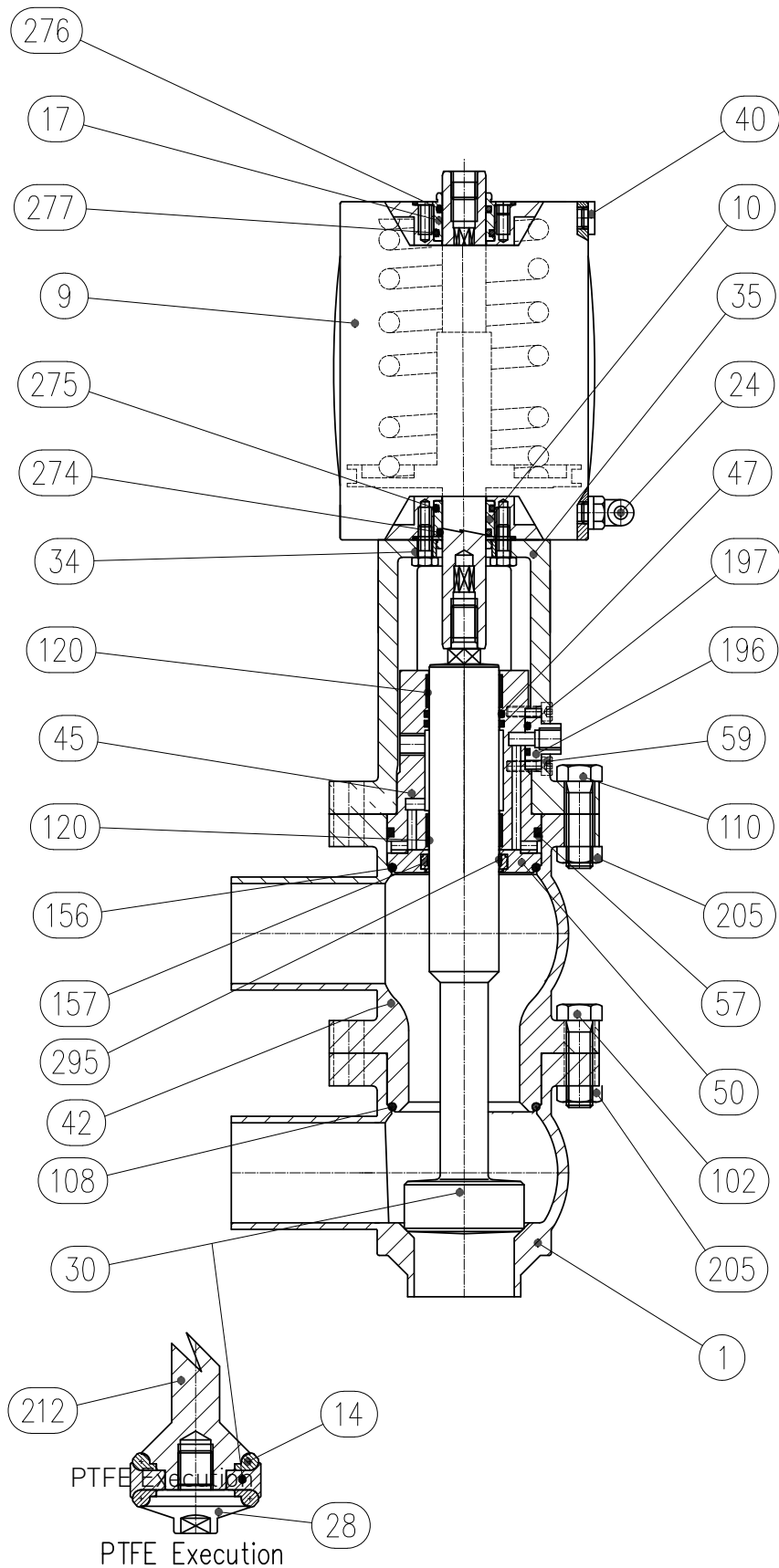

[BBZQ-108-156 DEV]

17 2D Diagram BBYQ P7 cylinder 108-156 Diverter

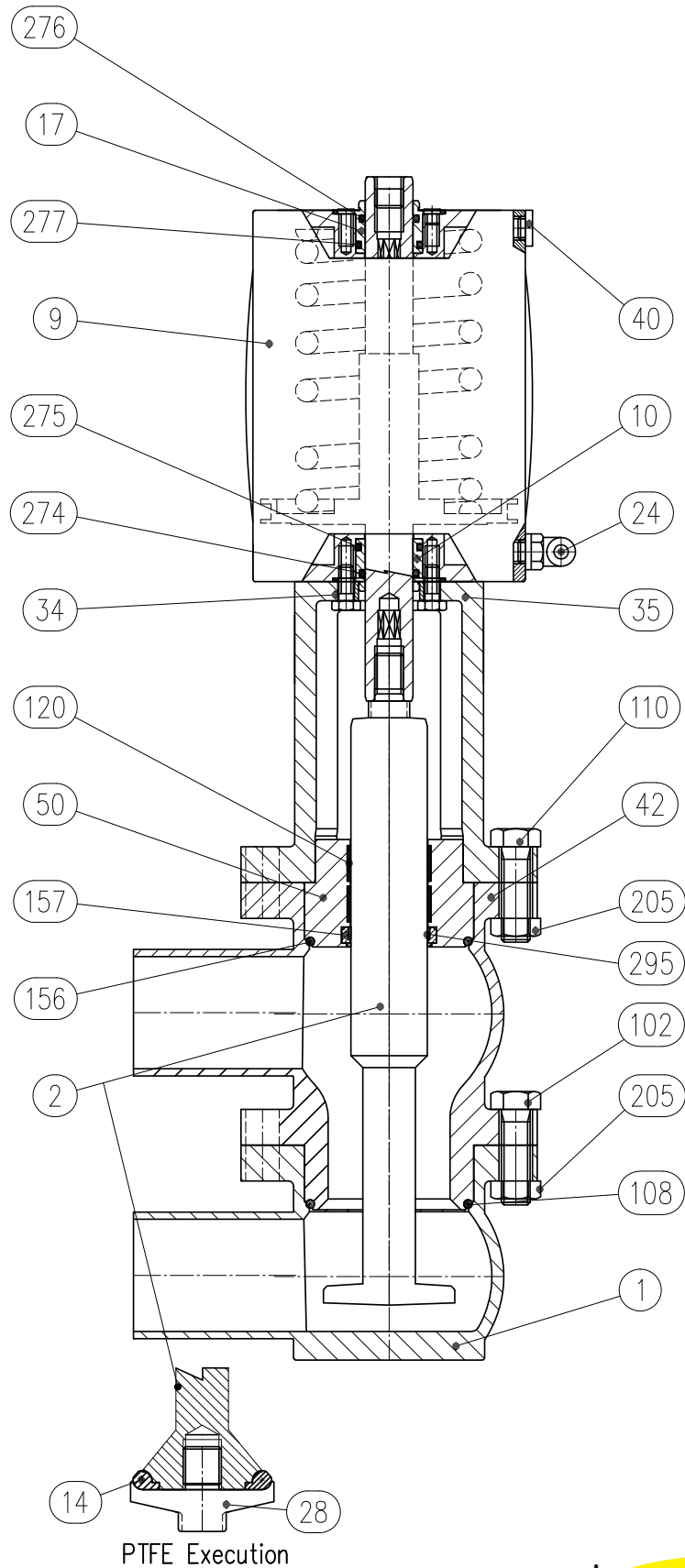

[BBZQ-108-156 DEV]

18 2D Diagram BBYQ cylinder 108-156

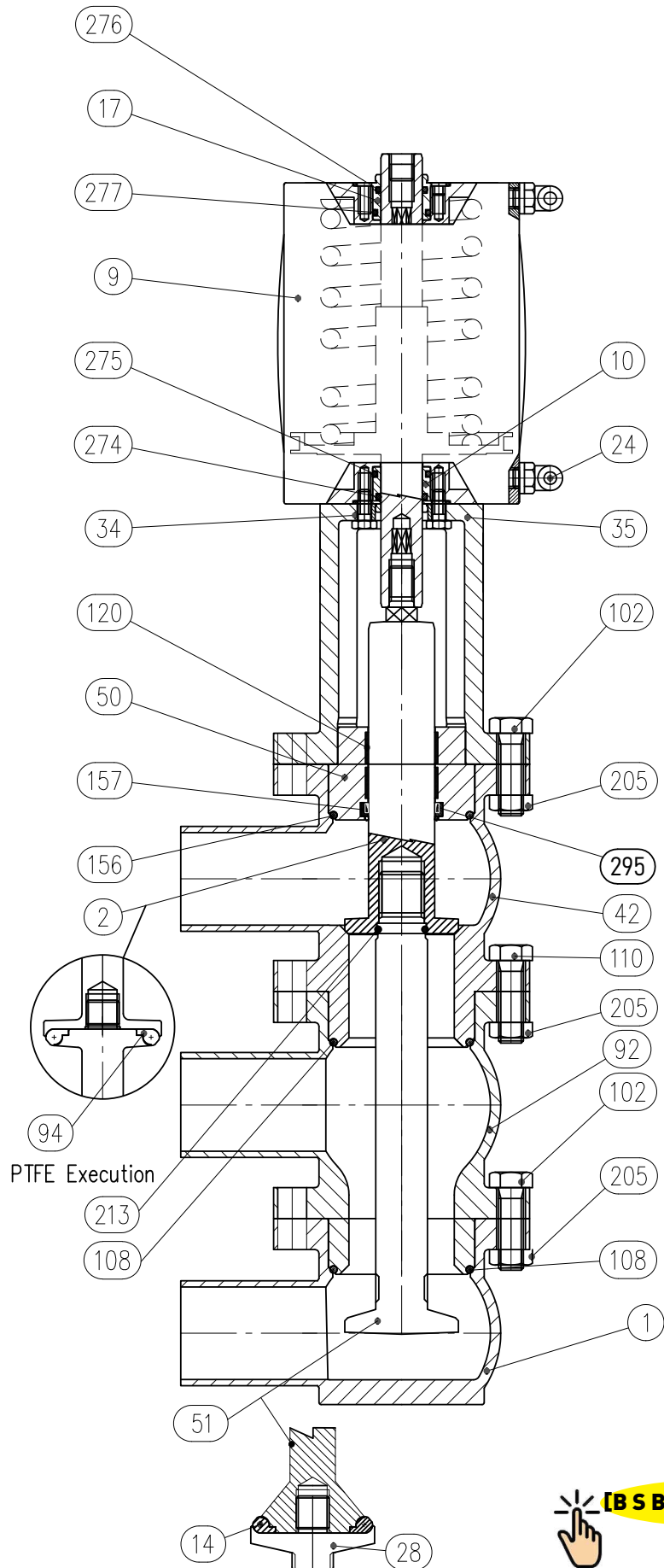

19 2D Diagram BBZQ cylinder 207-360

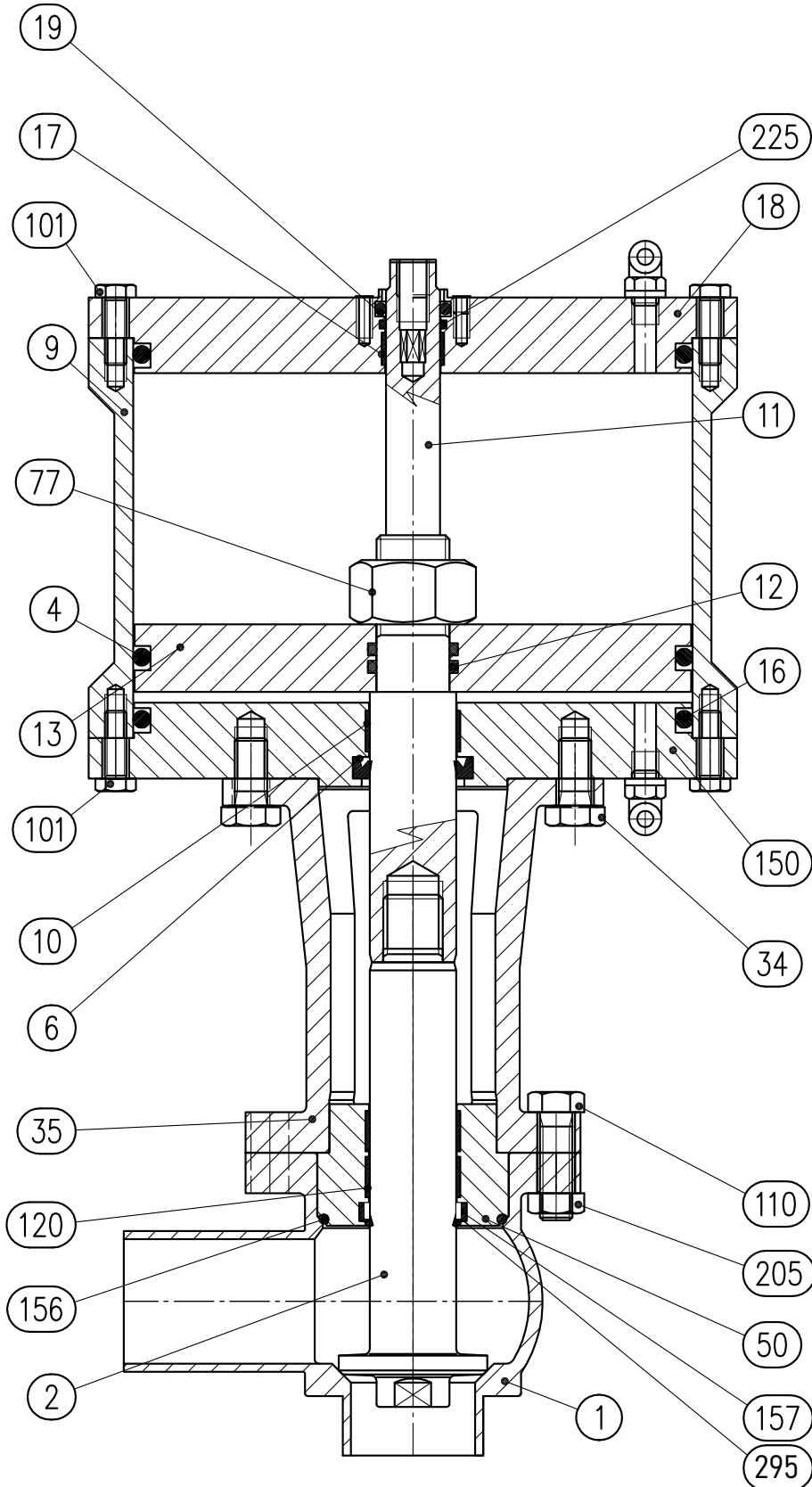

[S BBZQ-207-360]

20 2D Diagram BBYQ cylinder 207-360

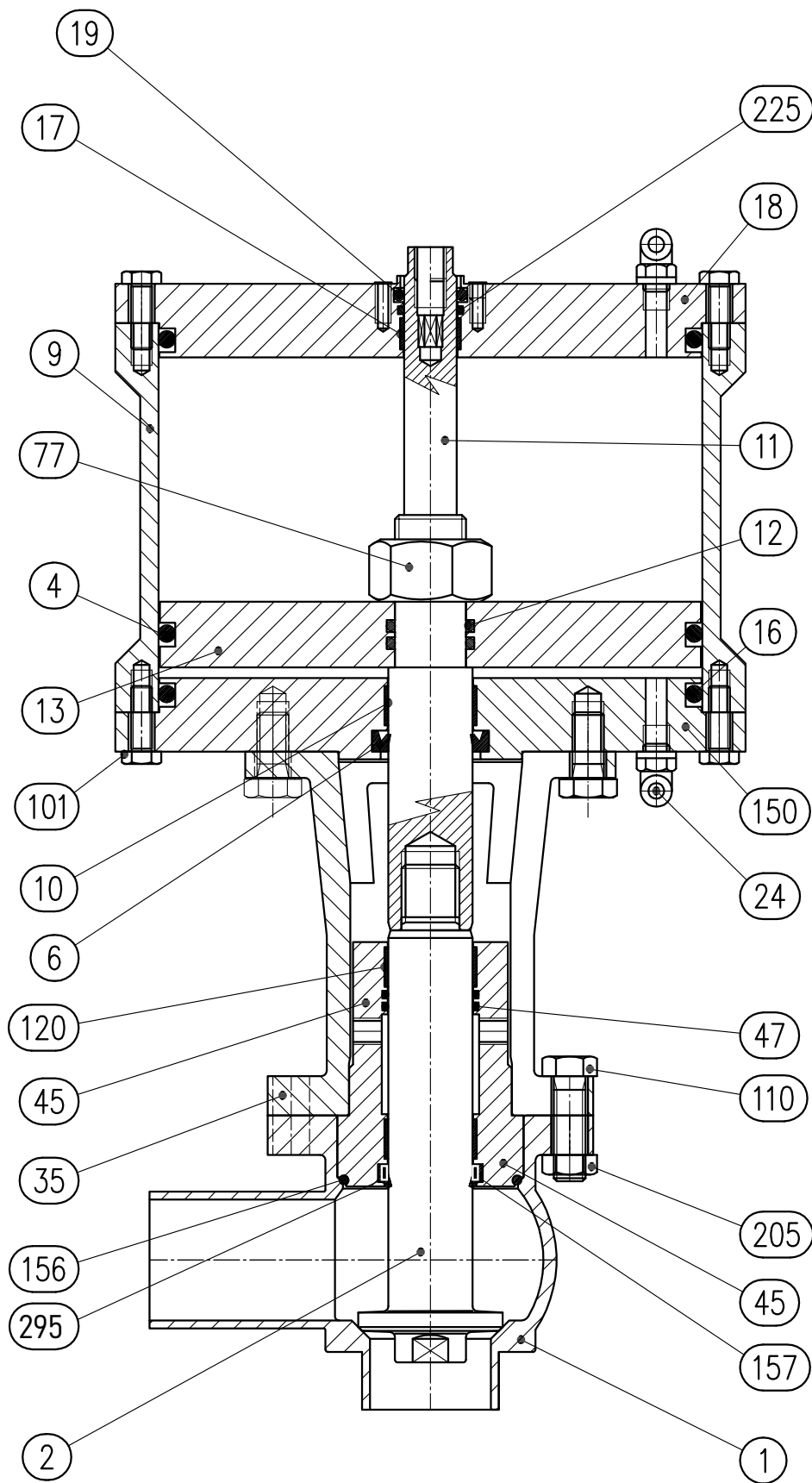

[S BBZQ-207-360]

21 2D Diagram BBYQ M8 cylinder 207-360

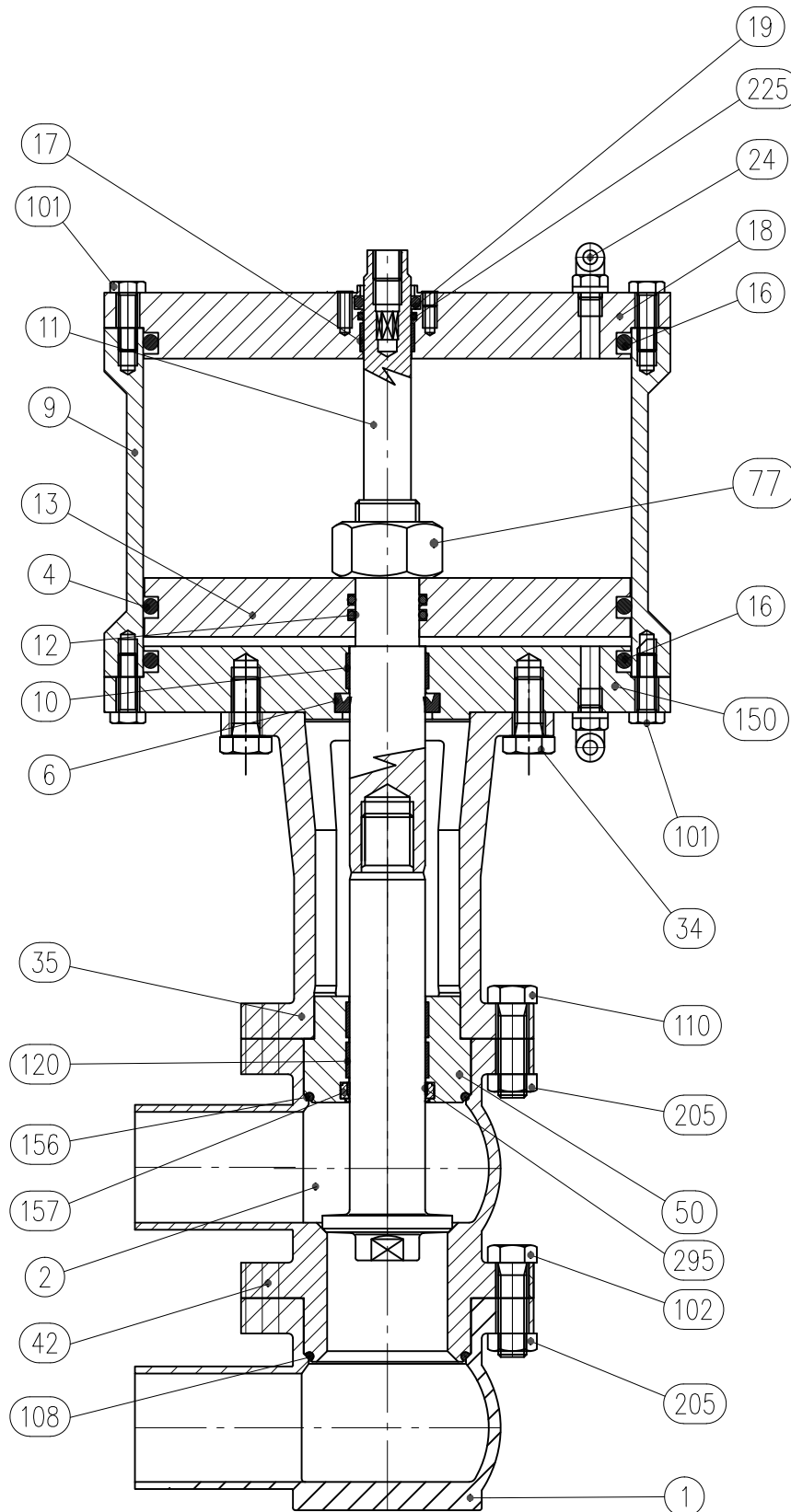

 [S BBZQ-207-360]

22 2D Diagram BBZQ cylinder 207-360 Diverter

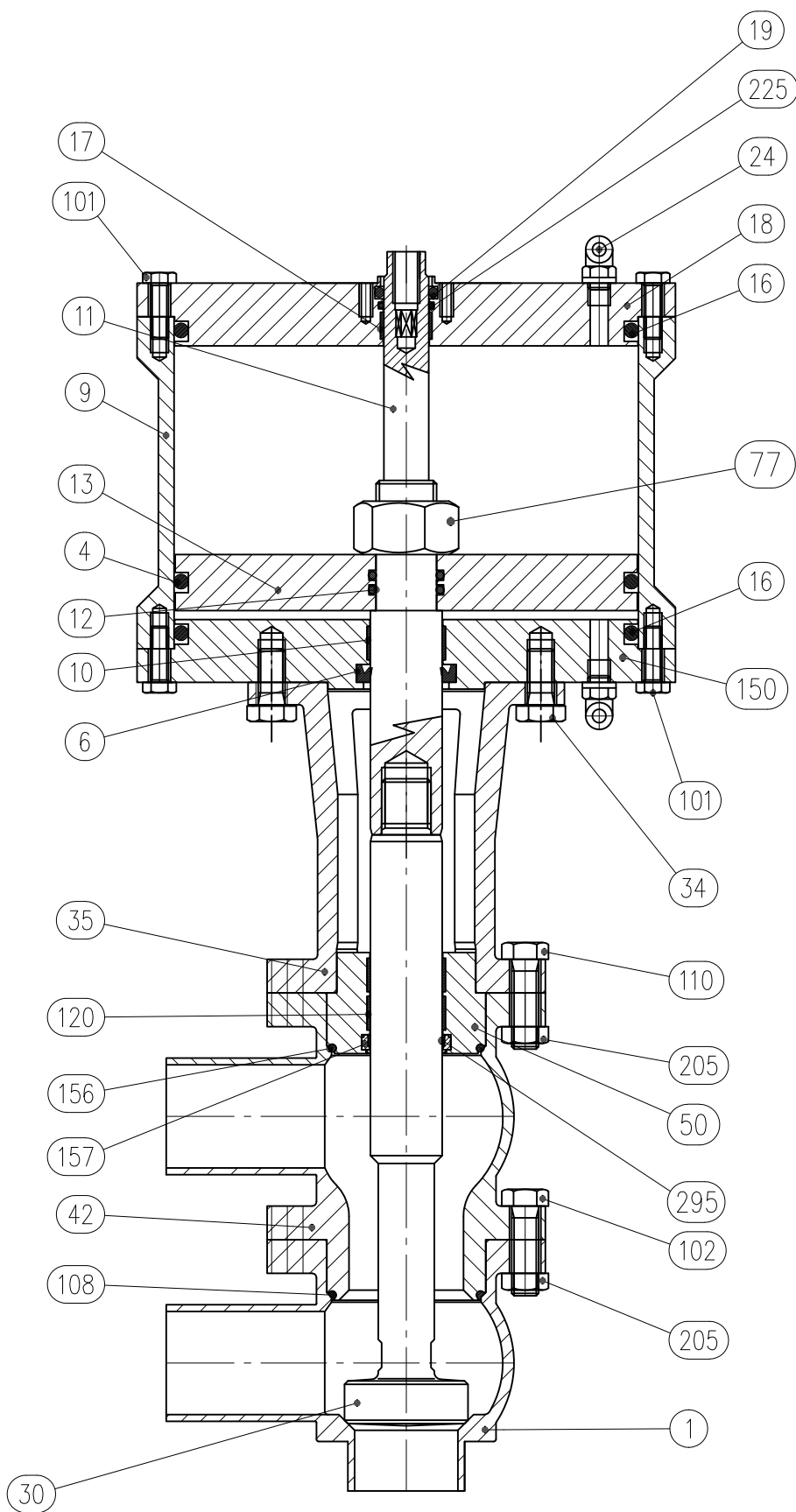

[BBZQ-207-360 DEV]

23 2D Diagram BBYQ cylinder 207-360 Diverter

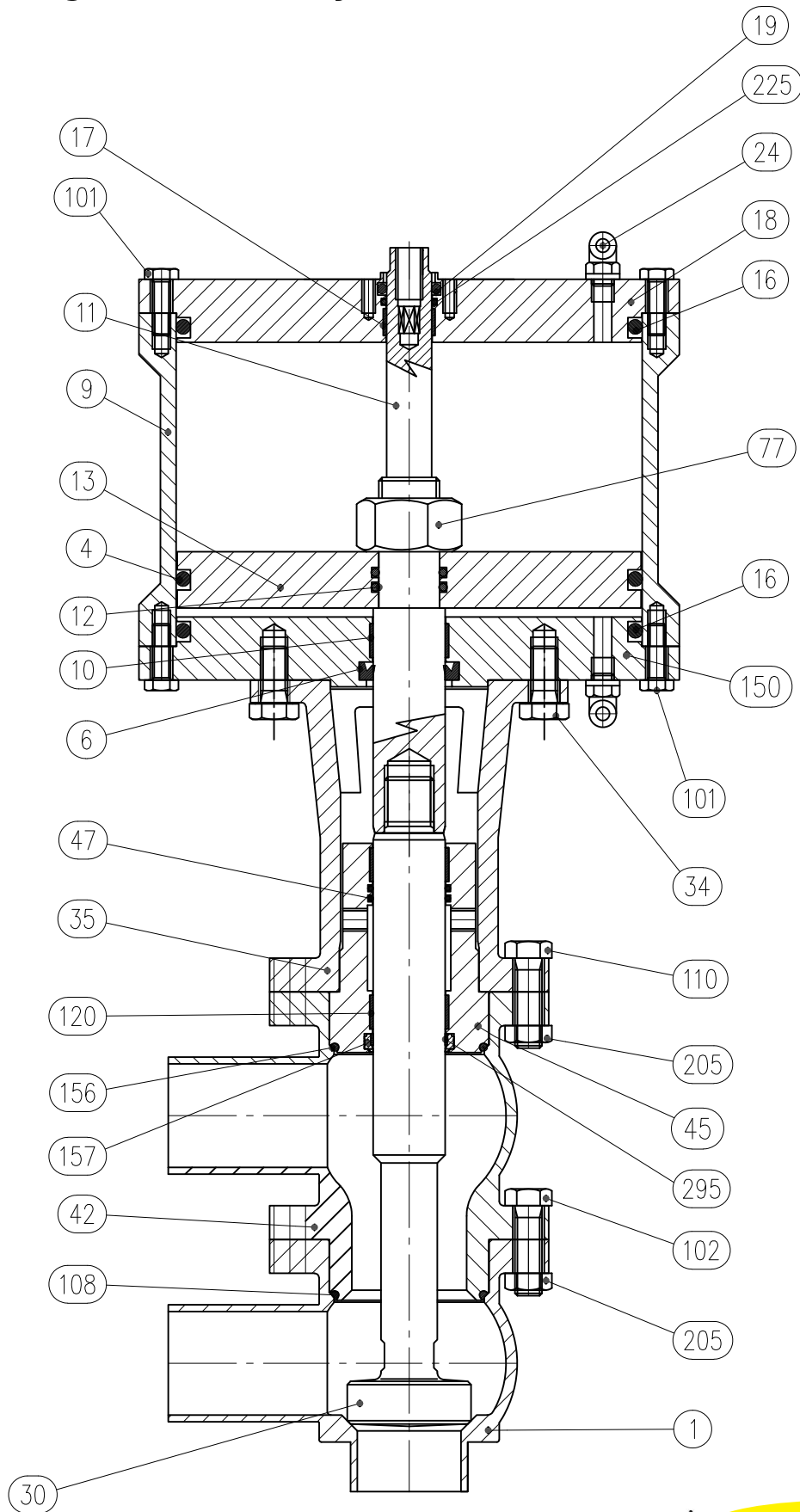

[BBZQ-207-360 DEV]

24 2D Diagram BBYQ P7 cylinder 207-360 Diverter

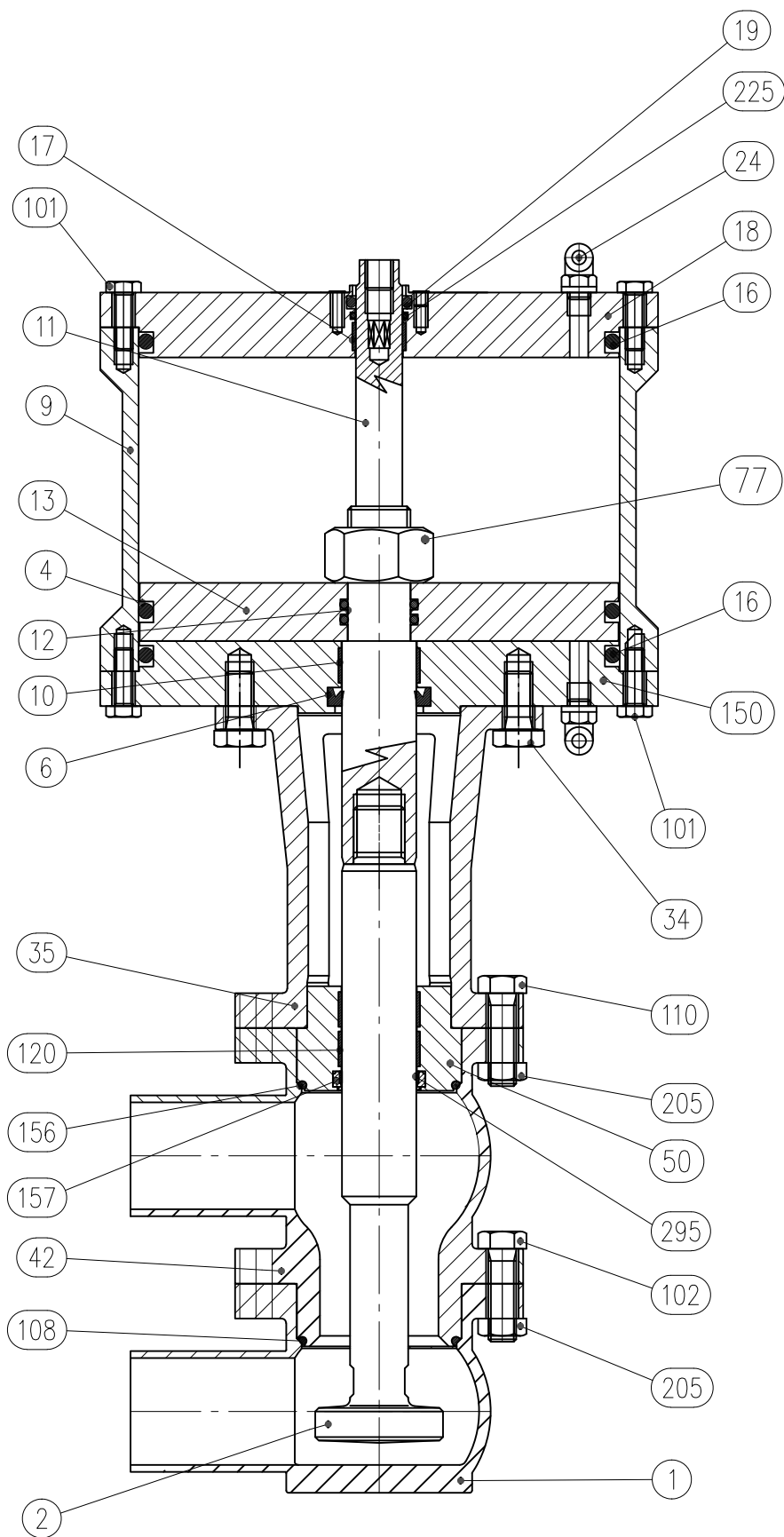

[BBZQ-207-360 DEV]

25 2D Diagram BBYQ M8-LLL cylinder 207-360 Diverter

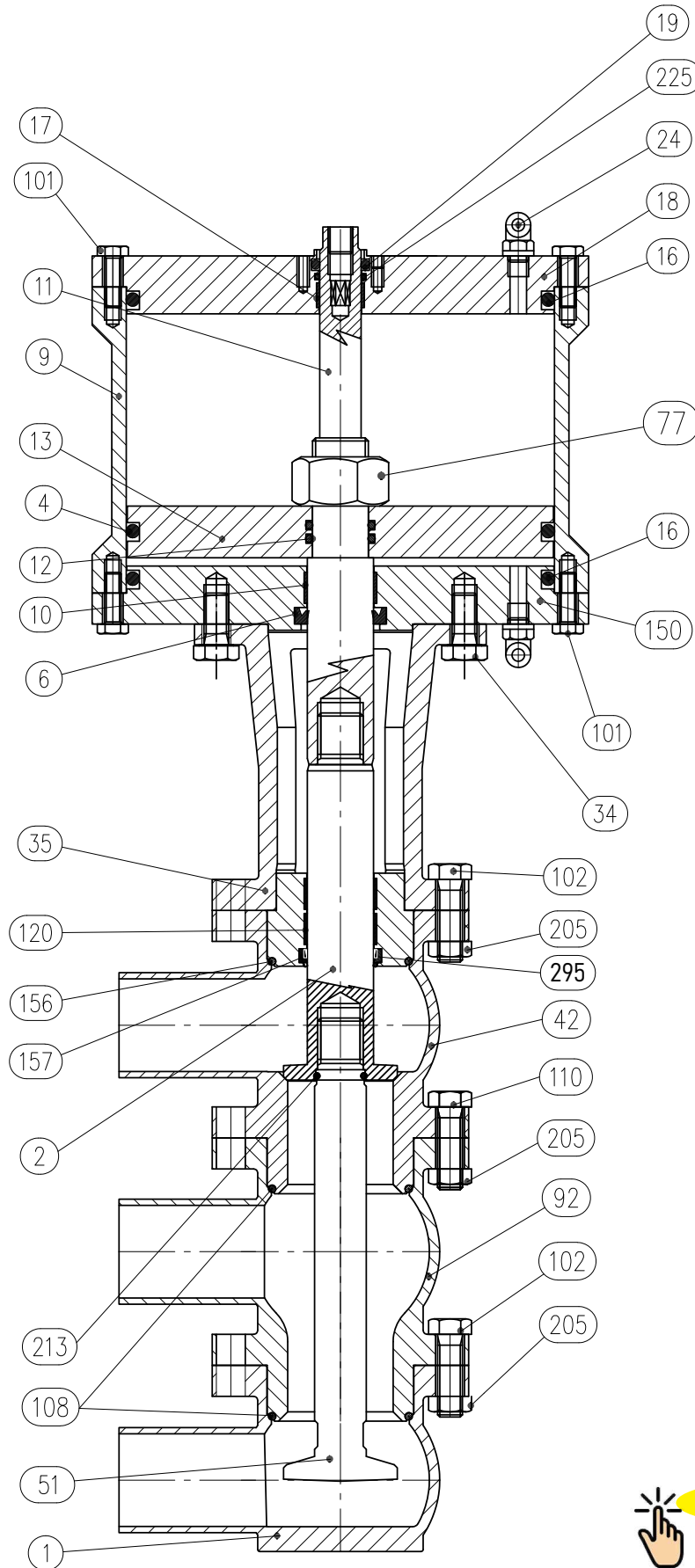

[BBZQ-207-360 DEV]

26 2D Diagram BBYQ cylinder with damper 207-360

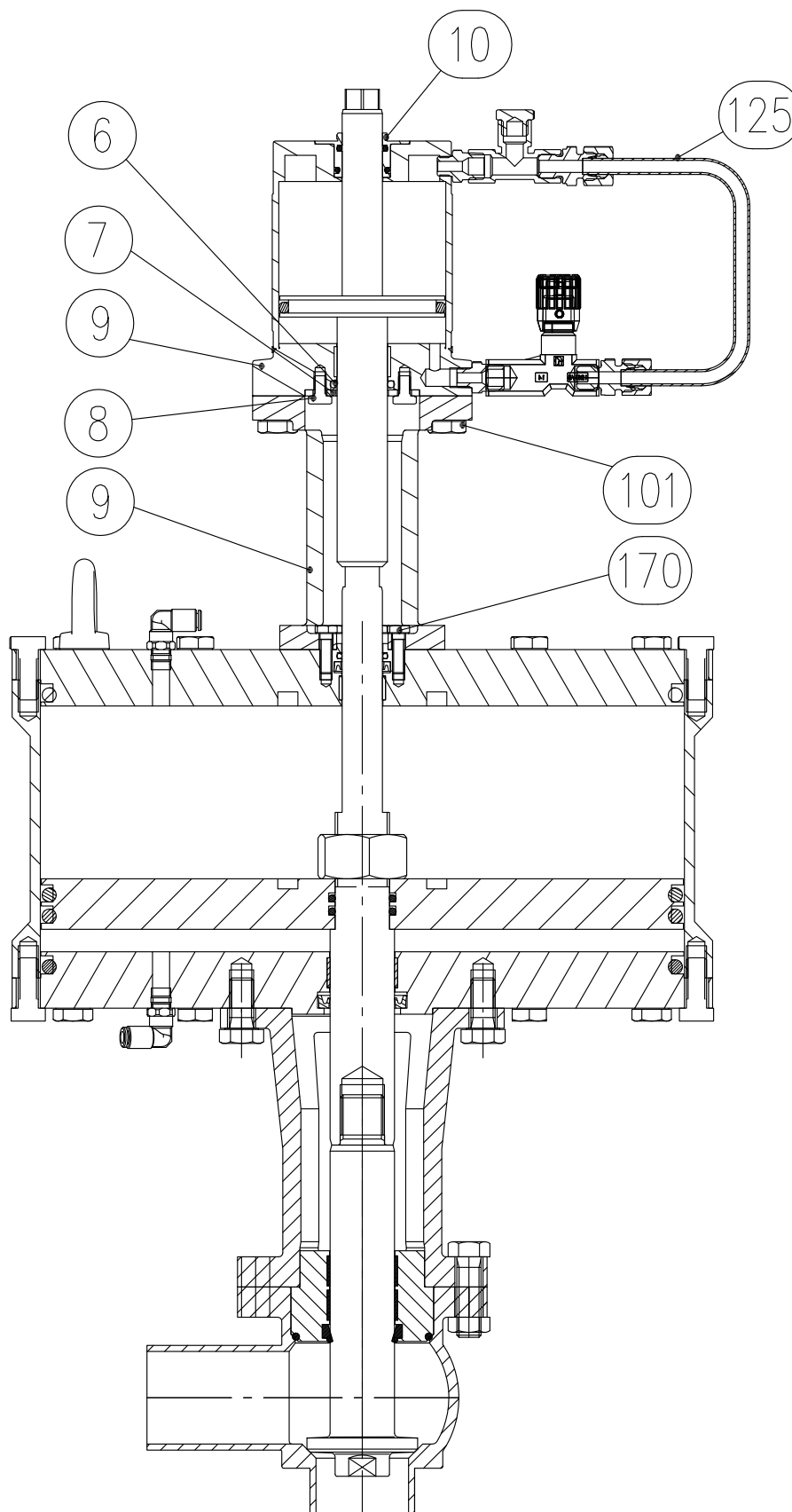

[SMORZ BBZQ-207-360]

27 2D Diagram BBZQ cylinder 108-156 With Pressure Regulator

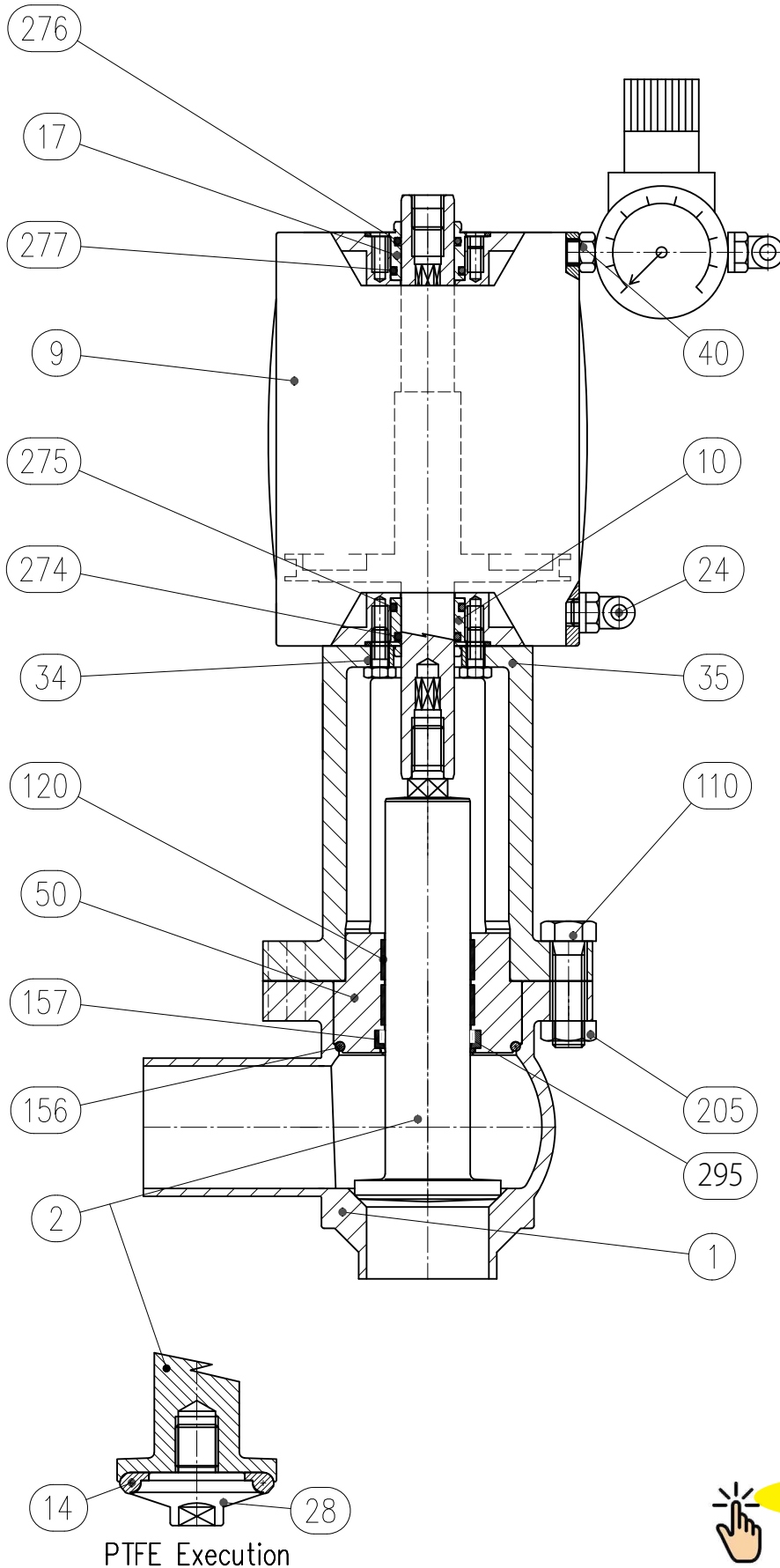

28 2D Diagram BBZU cylinder 108-156

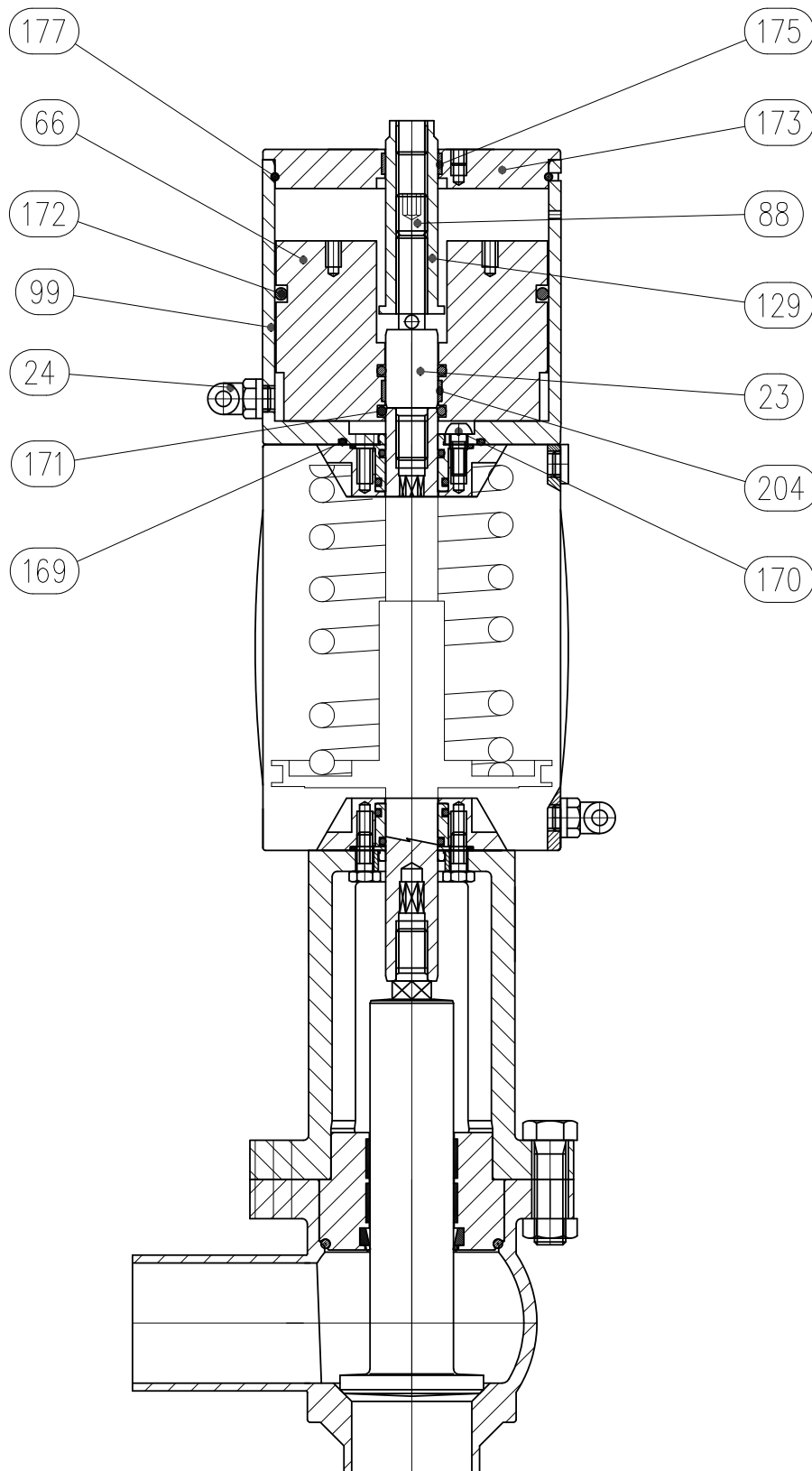

[BBZU]

29 2D Diagram BBZU cylinder 108-156

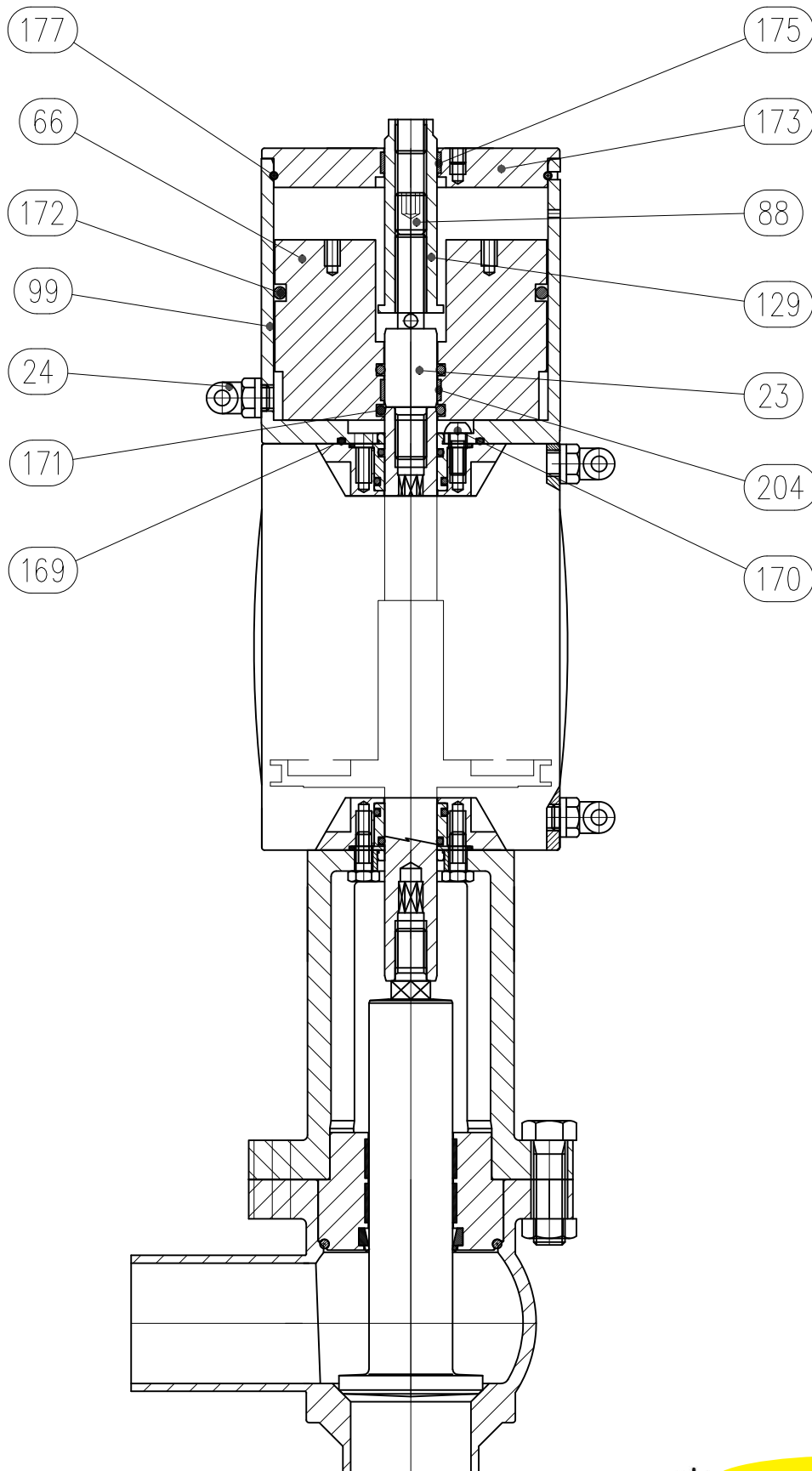

30 2D Diagram BBYQ cylinder 108-156 SPECIAL

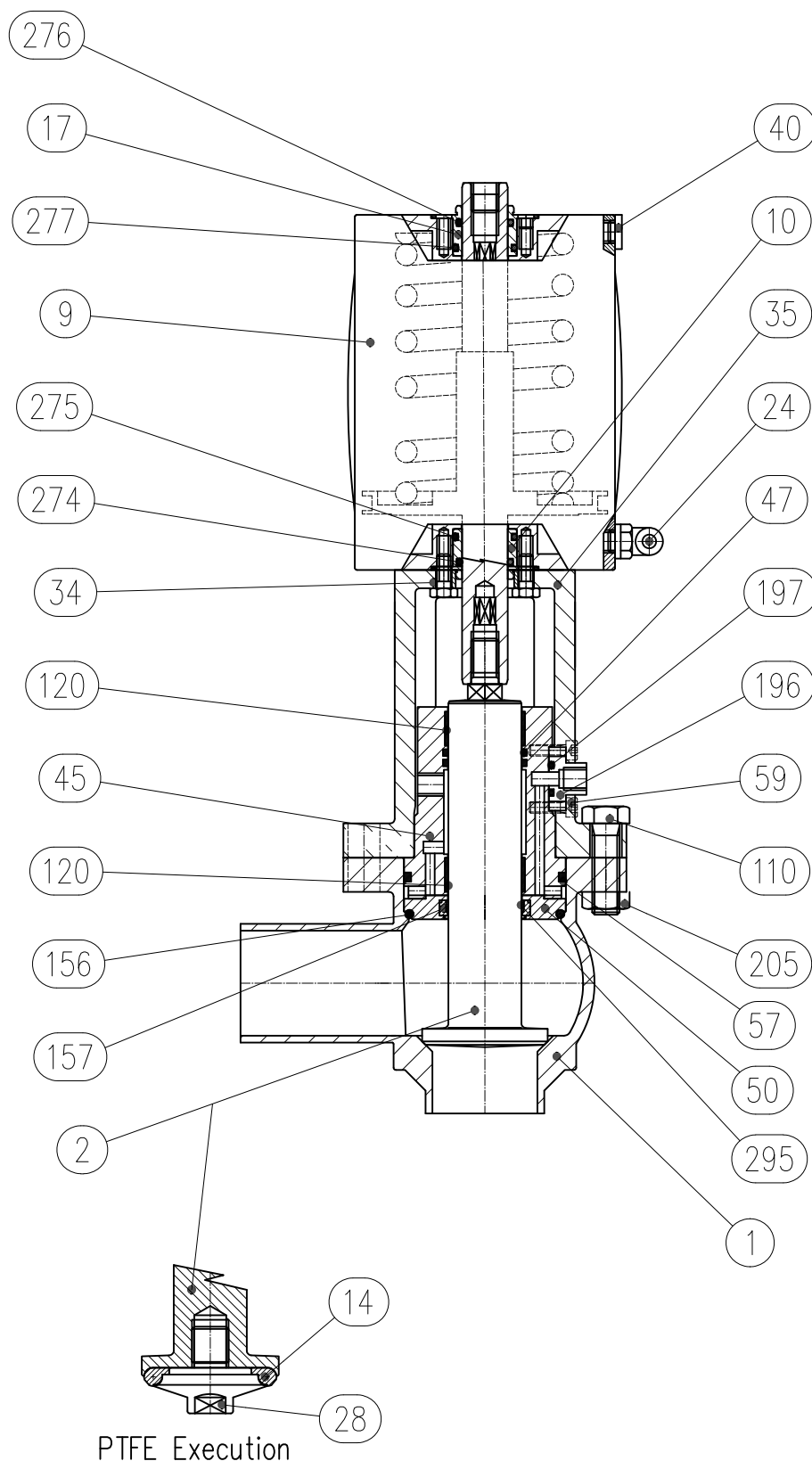

[BBZQ-108-156]

31 2D Diagram BBYQ cylinder 108-156 Diverter SPECIAL

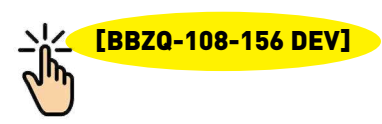
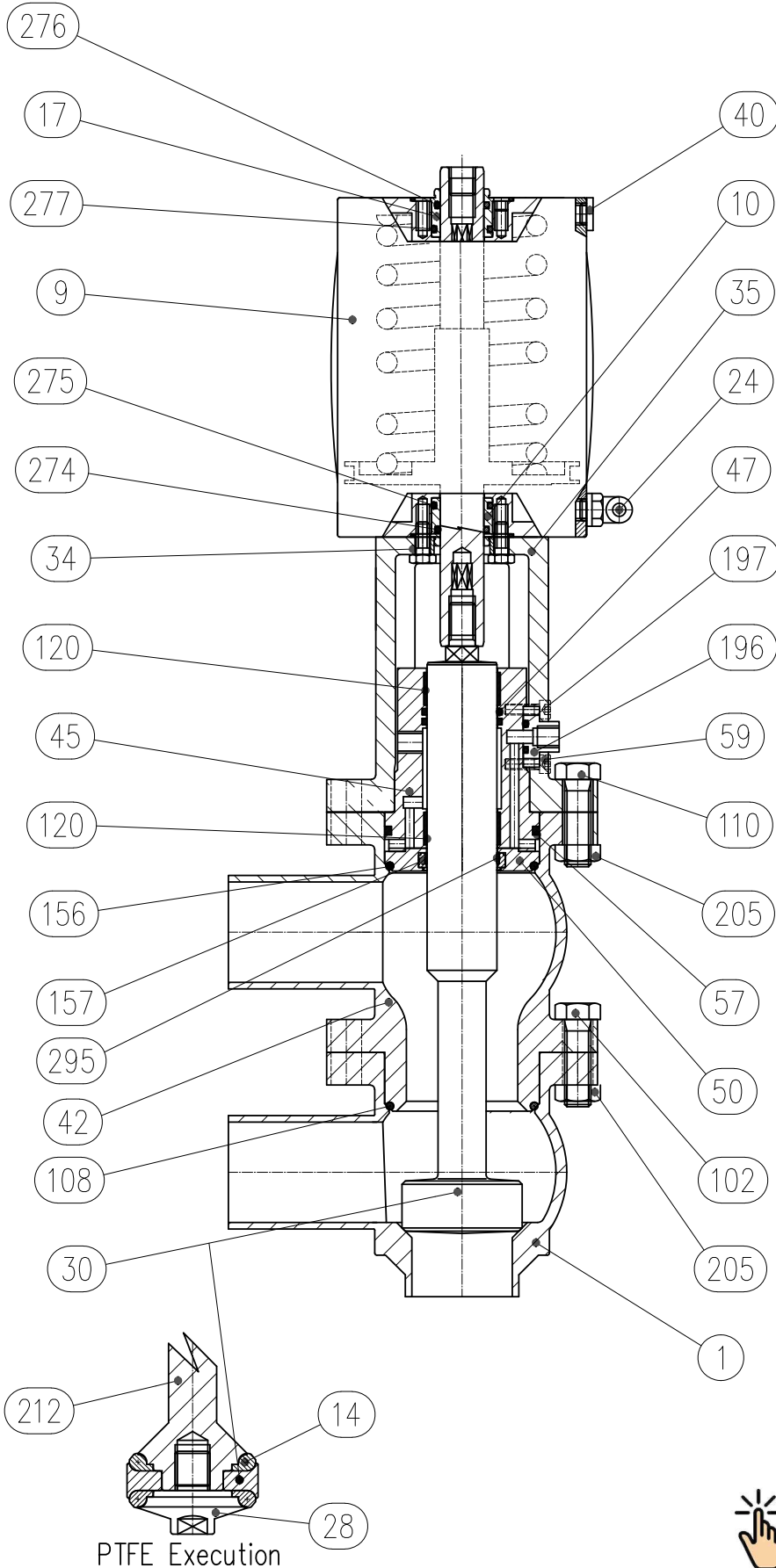

32 Warranty

1. VALIDITY

Bardiani Valvole's Products are manufactured in compliance with the technical specifications laid out in their "Instruction, Use and Maintenance Manual" and are fully compliant with the directives specifically mentioned in these manuals.

Bardiani Valvole S.p.A. guarantees its own Products against any design and/or construction and/or material defects and/or faults for a period of 12 (twelve) months from the date of delivery.

Notification of any Product defects and/or faults must be sent in writing to Bardiani Valvole S.p.A. within 8 (eight) days from their detection, providing adequate documentation of the defect/fault encountered as evidence.

Services provided in the warranty period shall not result in an extension of the warranty beyond the stipulated 12 (twelve)-month period, as this warranty validity period is to be considered mandatory.

2. CONTENTS OF THE WARRANTY

Notwithstanding and without prejudice to the rights of the Buyer, which may be acknowledged by applicable law, this warranty is to be intended as limited, at the discretion of Bardiani Valvole S.p.A., to the repair and/or replacement of the Product and/or part of the Product and/or its components which is/are found to be defective due to design and/or manufacturing and/or material faults.

In the event of repair and/or replacement of the Product and/or any one of its parts and/or components, any returned item/s shall become the property of Bardiani Valvole S.p.A. and the relative shipping costs shall be charged to Bardiani Valvole S.p.A.

Bardiani Valvole S.p.A., shall be under no obligation to compensate for any immaterial and/or indirect damages and shall in no way be held liable for consequential damages and/or losses, such as (by way of example only), damages due to loss of business, contracts, opportunities, time, production, profits, goodwill, image etc.

No retailer or distributor or dealer or agent or representative or employee or person appointed by Bardiani Valvole S.p.A. is authorized to make any amendments and/or integrations and/or extensions to this warranty.

3. WARRANTY EXCLUSIONS

- Elastomers are expressly excluded from this warranty.
- This warranty does not cover design faults emerging whenever a Product is manufactured by Bardiani Valvole S.p.A. based on designs and/or technical specifications provided by the Buyer.
- Moreover this warranty excludes the following:
 - faults and/or defects resulting from incorrect and/or unsuitable and/or inadequate transportation of the Product;
 - faults and/or defects resulting from failure to comply with the indications laid out in the "Instruction, Use and Maintenance Manual" with regards to installation of the Product or in any event caused by incorrect and/or unsuitable and/or improper installation;
 - faults and/or defects resulting from failure to comply with indications laid out in the "Instruction, Use and Maintenance Manual" with regards to use and/or maintenance operations and/or storage of the Product or in any event caused by incorrect and/or unsuitable and/or improper use and/or maintenance operations and/or storage;
 - faults and/or defects due to normal wear and tear of the Product and/or its parts and/or its components;
 - faults and/or defects in the Product and/or its parts and/or its components for work and/or repairs being carried out by unskilled staff or staff that has not been authorised by Bardiani Valvole S.p.A.;
 - faults and/or defects in the Product and/or its parts and/or its components due to it/them being dropped and/or banged and/or dented and/or misused and/or tampering and/or breakage and/or accidents or in any event due to negligence and/or carelessness and/or neglect by the Buyer and in general for any causes not attributable to design and/or manufacturing and/or material defects;
 - faults and/or defects in the Product and/or its parts and/or its components caused by other events beyond the control of Bardiani Valvole S.p.A., such as force majeure or unforeseeable circumstances.

33 Recommendations

- 1.** Consultation of the "Instruction, Use and Maintenance Manual" is mandatory prior to the installation, use and maintenance of the products of all Products. All the information, indications, specifications, technical details provided herein are based on test data which the Manufacturer Bardiani Valvole S.p.A. holds to be reliable nevertheless the above is not deemed to be assumed as fully exhaustive inasmuch as not every possible use has been envisaged.
- 2.** All the illustrations and drawings provided are to be intended as indicative and therefore not binding, the illustrations being for presentation purposes only.
- 3.** It is the Buyer's duty to assess the suitability of the products for the use he intends to make of the same prior to placing the order as he/she will take the risks and accept liability in case of incorrect choice and use of the Products.
- 4.** The Manufacturer strongly recommends the Buyer to contact their sales team and request any information that might be needed in relation to the specifications and uses of the Products.
- 5.** The information provided in this manual refers to the standard products manufactured by Bardiani Valvole S.p.A. and therefore cannot be assumed to apply to customized products as well.
- 6.** Bardiani Valvole S.p.A. reserves the right to amend and/or integrate and/or update the data and/or information and/or technical details relative to Products at any time and without prior notice. Please visit the website www.bardiani.com, where the latest updated of the "Instruction, Use and Maintenance Manual" can be found".
- 7.** The content and validity of the warranty covering the Products of Bardiani Valvole S.p.A are dealt with in the relevant section in the "Instruction, Use and Maintenance Manual" which constitutes an integral part of the Products themselves.
- 8.** Bardiani Valvole S.p.A., shall not in any way be held liable for immaterial, indirect and consequential damages, such as (by way of example only), damages or loss of business, contracts, opportunities, time, production, profits, goodwill, image etc..

NOTES

Bardiani Valvole S.p.A.
via G. di Vittorio, 50/52 - 43045 Fornovo di Taro (PR) - Italy
tel. +39 0525 400044 - fax +39 0525 3408
bardiani@bardiani.com - www.bardiani.com