

Valvole alta pressione  
High pressure valves

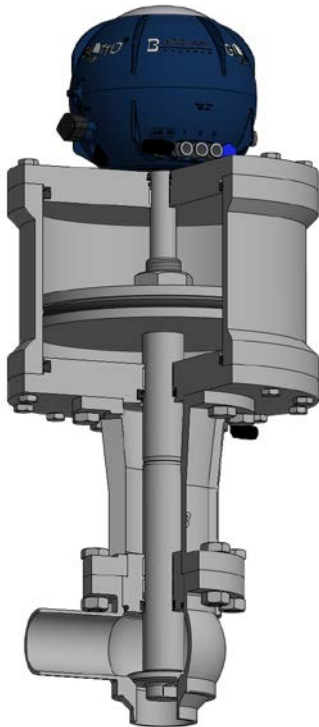

**B** BZQ

BBZQ



BBZQ

deviatrice/divert

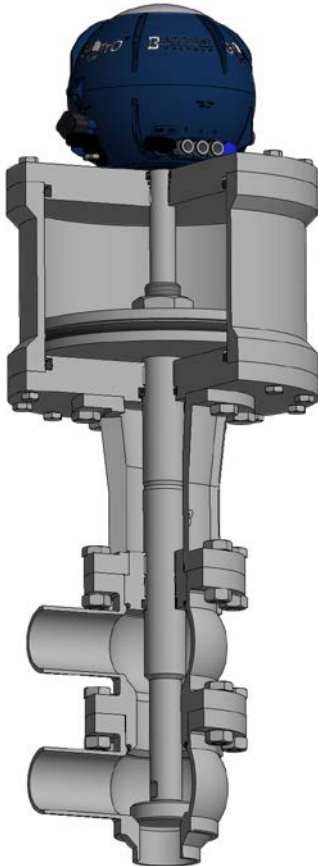

CERTIFICAZIONI  
CERTIFICATIONS



## DATI TECNICI

STRUTTURA VALVOLA			
Connessioni da DN25 a DN100	Attacchi a saldare		Altre connessioni a richiesta
Materiale a contatto con il prodotto	AISI 316L (1.4404) I corpi sono ricavati interamente da massello pieno		Altro materiale a richiesta
Materiale guarnizioni a contatto con il prodotto (omologazione FDA)	EPDM, FKM e PTFE		Altro materiale a richiesta
Temperatura massima prodotto (applicazioni con aria)	150°C (302 °F) FKM	140 °C (284 °F) EPDM	Per temperature diverse contattare Bardiani Valvole
Temperatura minima prodotto (applicazioni con aria)	-10°C (14 °F) FKM	-10 °C (14 °F) EPDM	
Pressione massima prodotto	150 bar (2173 psi) DN25 -80 / DN25.4-76.1 55 bar (798 psi) DN100 / DN101.6		Valore massimo dipendente dalla tipologia degli attacchi/connessioni
Finitura superficie a contatto con il prodotto	Ra 0,8 µm (altri valori di finitura a richiesta)		
Connessioni barriera vapore	attacchi 1/8" (BSP)		
STRUTTURA ATTUATORE PNEUMATICO			
Attacchi aria	1/8" (BSP) per tubo 6 x 4 mm		
Pressione	Da 6 bar (87 psi) a 8 bar (116 psi) per cilindro 108 a 156 Da 6 bar (87 psi) a 7 bar (101 psi) per cilindro 207 a 360		
Materiale cilindro	AISI 304 (1.4301)		
Materiale guarnizioni	NBR		

## TECHNICAL DETAILS

VALVE STRUCTURE			
Connections from DN25 to DN100	Weld ends		Other connections on request
Material in contact with the product	AISI 316L (1.4404) Valve bodies are made from solid stainless steel bar		Other material on request
Material gaskets in contact with the product (FDA homologation)	EPDM, FKM and PTFE		Other material on request
Max product temperature (applications with air)	150°C (302 °F) FKM	140 °C (284 °F) EPDM	For other temperature, please ask Bardiani Valvole
Min product temperature (applications with air)	-10°C (14 °F) FKM	-10 °C (14 °F) EPDM	
Max. product pressure	150 bar (2173 psi) DN25 -80 / DN25.4-76.1 55 bar (798 psi) DN100 / DN101.6		Maximum value depending on the type of weld ends / connections
Surface finish in contact with the product	Ra 0.8 µm (other surface finish value on request)		
Steam barrier connection	connectors 1/8" (BSP)		
PNEUMATIC ACTUATOR STRUCTURE			
Air connectors	1/8" (BSP) for pipe 6 x 4 mm		
Air pressure	From 6 bar (87 psi) to 8 bar (116 psi) for cylinders from 108 to 156 From 6 bar (87 psi) to 7 bar (101 psi) for cylinders from 207 to 360		
Cylinder material	AISI 304 (1.4301)		
Gasket material	NBR		

**BBYQ****VALVOLA ALTA PRESSIONE CON BARRIERA VAPORE**

Impiegata in applicazioni particolarmente delicate dove sterilità, asetticità o alte temperature di sterilizzazione sono necessarie. L'utilizzo di una barriera di vapore posta tra il corpo valvola e la parte pneumatica consente di ottenere una sicura separazione fra prodotto all'interno della valvola ed ambiente esterno.

**HIGH PRESSURE VALVE WITH STEAM BARRIER**

A steam barrier is recommended for hygiene application such as sterile, aseptic processing or high temperature sterilization. The steam barrier, placed between the valve body and the pneumatic actuator, avoid product contamination from external environment.

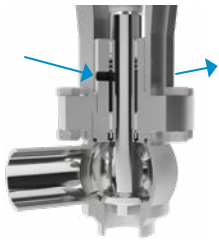
**APPLICAZIONE STANDARD/STANDARD APPLICATION**

Barriera vapore con flusso vapore solo su stelo  
Steam barrier with steam flow only on valve shaft

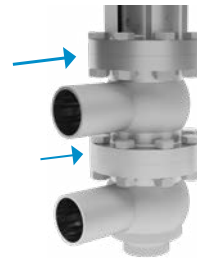
**SU RICHIESTA/ON REQUEST**

Barriera vapore con flusso vapore sullo stelo e tra le flange  
Steam barrier with steam flow on valve shaft and between flanges

**BBZMQ****VALVOLA ALTA PRESSIONE AD AZIONAMENTO MANUALE  
MANUAL OPERATED HIGH PRESSURE VALVE****BBZQM****VALVOLA ALTA PRESSIONE CON POSIZIONATORE**

Il posizionatore consente una regolazione sulla movimentazione dell'otturatore

**MODULATING HIGH PRESSURE VALVE**

Positioner allows a fine adjustment on the handling of the shutter.



## SMORZATORE IDRAULICO

Questo accessorio, applicato nella parte superiore dell'attuatore pneumatico, riguarda esclusivamente la linea delle valvole ad alta pressione.

Lo smorzatore idraulico determina un rallentamento nelle fasi apertura e chiusura della valvola, salvaguardando sia la durata delle tenute che l'eventuale formazione di colpi d'ariete nell'impianto.

## HYDRAULIC DAMPER

This auxiliary device, dedicated only to high pressure valves, is mounted on the top of the pneumatic actuator.

The hydraulic damper causes a slowdown in the opening and closing phases of the valve, increasing gaskets service life and avoiding water hammer in pipeline.

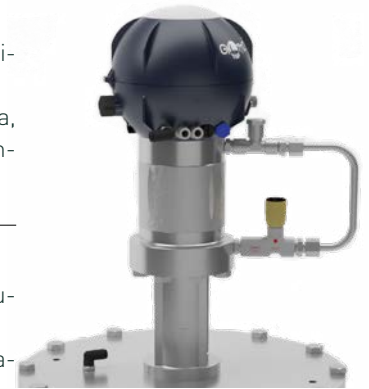

# BBZU

## VALVOLA PNEUMATICA ALTA PRESSIONE SINGOLA SEDE SE/NC BBZU TWIN STOP

### HIGHT PRESSURE SE/NC PNEUMATIC SINGLE SEAT BBZU TWIN STOP

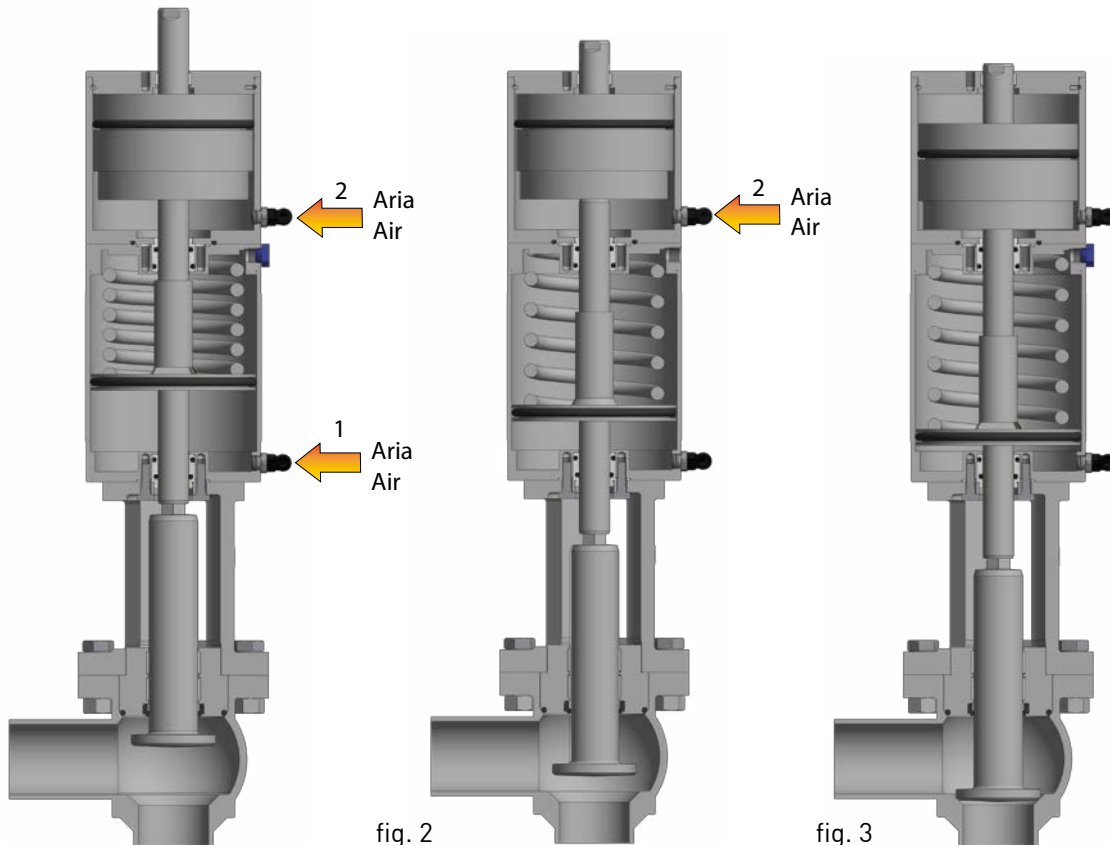

fig. 1

fig. 2

fig. 3

## FUNZIONAMENTO

Per ottenere l'apertura della valvola semplice effetto normalmente chiusa (SE NC), alimentare entrambi i cilindri con ingresso aria 1 e 2 (fig. 1). Togliendo aria dal cilindro inferiore si ottiene la chiusura parziale della valvola (fig. 2), questo movimento può essere registrato tramite l'apposito dispositivo di regolazione. Per effettuare la chiusura totale della valvola è sufficiente togliere aria dal cilindro superiore (fig. 3). È anche possibile ottenere un'apertura parziale della valvola alimentando solo il cilindro superiore tramite l'ingresso aria 2.

## WORKING PRINCIPLE

To open the valve with normally closed actuator with single acting (SE NC), supply air to both connections 1 + 2 (fig. 1). For partial closing release the air on the connection 1, while maintaining pressure on air connection 2 (fig. 2) the valve will partially close, this stroke can be adjusted and fixed, by a mechanical device equipped on the top of the valve. To close completely release the air from inlet 2 (fig. 3), both cylinders will now be free of air, and the spring returns the shutter in lower position. For partial opening, supply air to inlet 2 only.

### APPLICAZIONE BY-PASS

BBZQ EQUIPAGGIATA CON REGOLATORE DI PRESSIONE E MANOMETRO

Il regolatore di pressione è la giusta soluzione per utilizzare la valvola come by-pass. Tramite questo dispositivo è possibile regolare la pressione dell'aria nel cilindro pneumatico, considerando la pressione di tenuta.

Dotato di regolatore di pressione, il manometro mostra l'alimentazione dell'aria.

### BY-PASS APPLICATION

BBZQ EQUIPPED WITH PRESSURE REGULATOR AND MANOMETER

The pressure regulator is a good solution for pneumatic by-pass valve. With this device, it is possible to regulate the air pressure into the pneumatic actuator, considering sealing pressure.

Fitted with pressure regulator, the manometer shows air supplying.



### ESECUZIONI SPECIALI SU RICHIESTA

Ogni accessorio è disponibile su richiesta del cliente per tutti i diametri e tutte le configurazioni corpi valvola.

È inoltre possibile la personalizzazione di attacchi, diametri oppure soluzioni non presenti a catalogo.

Bardiani Valvole consiglia di consultare sempre l'ufficio tecnico in fase d'ordine per ulteriori informazioni e studi di fattibilità.

### SPECIAL SOLUTION ON REQUEST

On request all accessories are available for all valve sizes and body configurations.

Special ports, diameters and other customized solutions are available.

Bardiani Valvole provides technical support, advice and feasibility analysis for other requests.

BBZQ CYL.108-156				
DN	S	S1	S2	
25 - 1"1/2	20	20	11	
32	22	22	11	
40 - 1" 1/2	22	22	11	
50 - 2"	36	32	14	
65 - 2" 1/2	36	32	20	
80 - 3"	36	32	25	
100 - 4"	36	32	25	

BBZQ CYL.207-360				
DN	S	S1	S2	
25 - 1"1/2	20	20	11	
32	22	26	11	
40 - 1" 1/2	22	26	11	
50 - 2"	29	41	12	
65 - 2" 1/2	44	51	20	
80 - 3"	56	51	26	
100 - 4"	56	51	32	

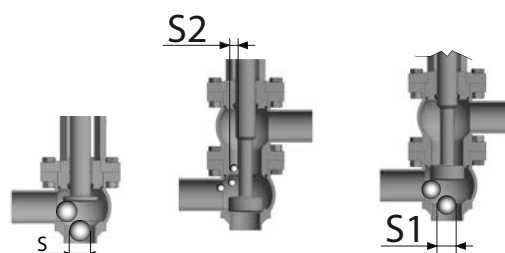

BBZQ CYL.108-156 (PTFE)				
DN	S	S1	S2	
25 - 1"1/2	15	17	10	
32	15	17	10	
40 - 1" 1/2	15	17	11	
50 - 2"	27	28	14	
65 - 2" 1/2	35	31	21	
80 - 3"	34	31	24	
100 - 4"	32	31	24	

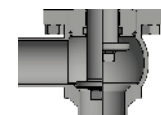
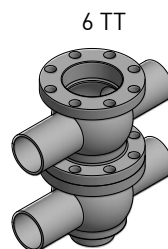
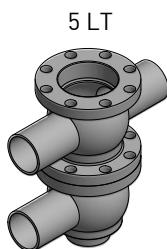
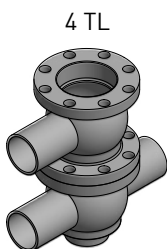
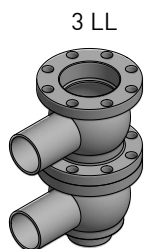
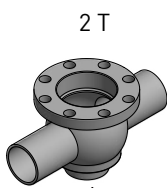
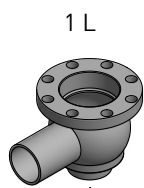

Chiusa Aperta  
Closed Open

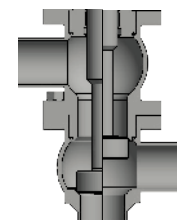

Chiusa Aperta  
Closed Open

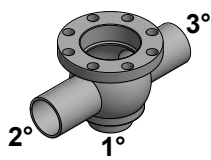
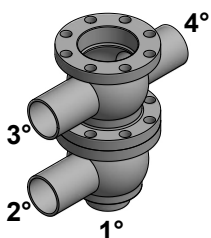

↑ Direzione fluido raccomandata  
↓ Recommended flow direction

1° - 2° - 3°... esempi di lettura per attacchi con tipi e/o dimensioni diverse

1st - 2nd - 3rd .... examples of how to read end connections with different types and/or dimensions

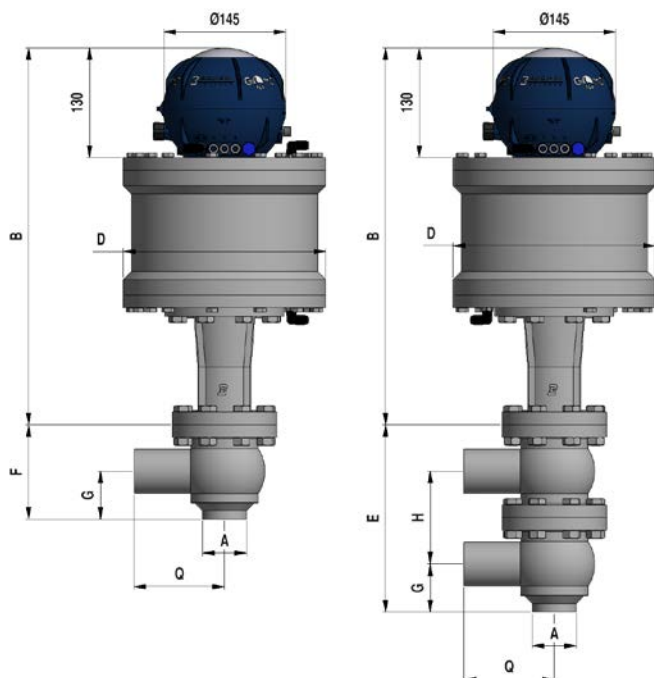

SALDARE / WELDING (S/S) DIN						
DN	A	E	F	G	H	Q
25	28x2.5	186.5	96.5	45.5	96	90
32	34x2.5	186.5	96.5	48.5	93	90
40	40x2.5	186.5	96.5	51.5	90	90
50	52x3	222	112	57	110	107
65	70x5	265	135	69	131	130
80	85x5	300.5	153.5	80	147	135
100	101.6x3	347	179	95	168	150

DN	A	E	F	G	H	Q
1"	25.4x2.5	186.5	96.5	44	97.5	90
1" 1/2	38.1x2.5	186.5	96.5	50.5	91	90
2"	50.8x3	222	112	56	111	107
2" 1/2	63.5x5	265	135	66	134	130
3"	76.1x5	300.5	153.5	75.5	151.5	135
4"	101.6x3	347	179	95	168	150

CIL / CYL	B	D
108	410	115
134	440	140
156	470	168
207	447	240
320	447	348
360	447	400

D.E. / D.A. PRESSIONI DI TENUTA PTFE / PTFE SEAL PRESSURE (bar) *				
DIN / DN	INCHES / DN	P1 / P2 / P3		
		Cil. 108 bar / psi	Cil. 134 bar / psi	Cil. 156 bar / psi
25	1"	26/377	41/594	56/812
32		26/377	41/594	56/812
40	1"1/2	26/377	41/594	56/812
50	2"	19/275	29/420	40/580
65	2" 1/2	12/174	19/275	25/362
80	3"		12/174	16/232
100	4"			12/174

D.E. / D.A. PRESSIONI DI TENUTA METALLO / METAL SEALPRESSURE (bar) *							
DIN / DN	INCHES / DN	P1 / P2 / P3					
		Cil. 108 bar / psi	Cil. 134 bar / psi	Cil. 156 bar / psi	Cil. 207 bar / psi	Cil. 320 bar / psi	Cil. 360 bar / psi
25	1"	29/420	45/652	61/884	108/1566		
32		29/420	45/652	61/884	108/1566		
40	1"1/2	29/420	45/652	61/884	108/1566		
50	2"	20/290	31/449	43/623	76/1102	150/2175	
65	2" 1/2	13/188	20/190	27/391	48/696	115/1667	147/2138
80	3"		12/174	17/246	30/435	72/1044	92/1334
100	4"			12/174	22/319	54/783	55/798

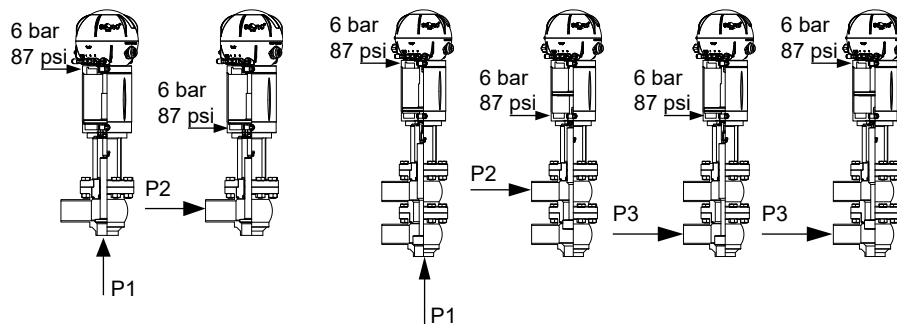

Opzionale:

- cil.108, cil.134, cil.156 D.E. N.C. e D.E. N.A. con molla da definire con l'ufficio tecnico Bardiani Valvole S.p.A.
- cil.207, cil.320, cil.360 D.E. N.C. con molla da definire con l'ufficio tecnico Bardiani Valvole S.p.A.

Optional:

- cil.108, cil.134, cil.156 D.A. N.C. and D.A. N.O. spring closes version to be defined by Bardiani Valvole S.p.A. technical department
- cil.207, cil.320, cil.360 D.A. N.C. spring closes version to be defined by Bardiani Valvole S.p.A. technical department

LEGENDA / KEY	
DIN / DN	Diametro nominale / Nominal diameter
D.E / D.A.	Valvola con attuatore a doppio effetto (aria apre/aria chiude) Valve with double acting actuator (air opens/air closes)
D.E.N.C / D.A.N.C.	Valvola con attuatore a doppio effetto con molla (in assenza di aria la molla chiude) Valve with double acting actuator with spring (spring closes without air)
D.E.N.A. / D.A.N.O	Valvola con attuatore a doppio effetto con molla (in assenza di aria la molla apre) Valve with double acting actuator with spring (spring open without air)
-	Su richiesta / On demand

\*Tabelle dati teorici, per maggiori informazioni potete chiedere al nostro ufficio commerciale  
Valori validi con alimentazione aria non inferiore a 6 bar  
Theoretical data table, for further information ask to our sales office  
Values are valid for air supply not less than 6 bar

